

Technical Brochure

LTG Air-Water Systems

LTG **FanPower**

Fan coil units

VKE, VKH, VDC, LVC

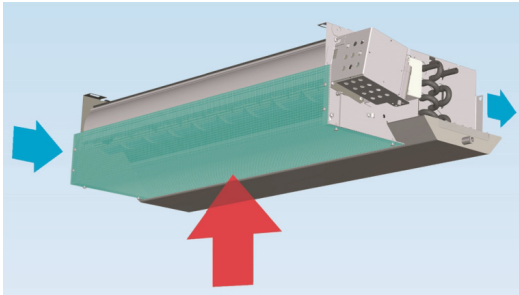

Ceiling installation

Fan coil units for ceiling installation

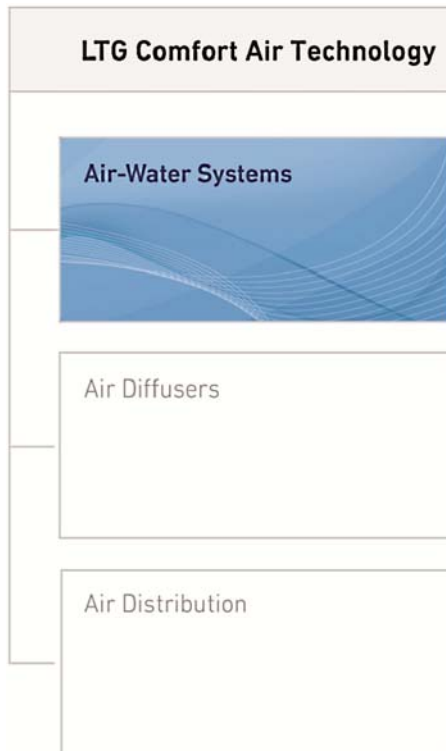

Content	Page
Function, advantages, accessories, special versions	3
Type VKE	4
Type VKH Ventotel®	17
Type VDC	27
LTG System Indivent® with type LVC	34
Specifications	

Notes

Dimensions stated in this brochure are in mm.

Dimensions stated in this brochure are subject to General Tolerances according to DIN ISO 2768-vL.

For the outlet grille special tolerances stated in the drawing apply.

Straightness and twist tolerances for extruded aluminium profiles according to DIN EN 12020-2.

The surface finish is designed to meet the requirements for applications in buildings - room climate according to DIN 1946 part 2. Other requirements on request.

The actual tender documentations are at the end of this document.

They are available in word format at your local dealership or at www.LTG-AG.com.

Fan coil units for ceiling installation

Function

LTG fan coil units Raumluft use an integrated fan that draws in the ambient air. In a water-fed heat exchanger this air is cooled or heated, then discharged again into the room. The heat exchanger is usually equipped with a filter for protection.

Among the fan types used are cross-flow fans and centrifugal fans (for type VKE) all of which are low-noise and maintenance-free. Fan speed control is realized through a factory-mounted transformer with 5 secondary voltages, triggered through separate switches. The use of a bank of transformers offers the possibility to trigger several units at a time using only one switch.

The fan coil units re-circulate room air. However, on request they may also be delivered with a connection for fresh air.

The solid construction and finish of the fan coil units ensure both reliability and long-term functional safety.

Advantages

- **Versatile range**
 - two- and four-pipe systems
 - different sizes
- **Features**
 - low-noise tangential or centrifugal fan
 - energy-saving fan operation
 - units with fresh air supply (option)
- **Indoor air flow**
 - uniform air discharge over the entire unit length by a tangential fan
 - inlet and outlet grille with adjustable air guidance for optimum indoor air flow
 - a variety of flow patterns
- **Installation properties**
 - compact construction and minimum unit height
 - low installation depth
- **Complete packaged systems**
 - integrated control systems
 - integrated ventilation systems, including fan coil units and linear diffusers
- **Maintenance**
 - easily removable, maintenance-free fan
 - easy replacement of filter, filter class G2 (EU2)
 - convenient, accessible heat exchanger on the suction side

Types

LTG offers different types for any application. The main distinctive feature of the LTG induction units is the way the temperature is controlled.

Two-pipe system

The unit has only one heat exchanger through which chilled water flows for cooling and hot water for heating. Thus, it is only possible to either heat or cool in a single water circuit.

Four-pipe system

The unit has two separate water systems, one for heating, the other for cooling. Thus, chilled and hot water will always remain separate. The four-pipe system fulfills all requirements on varying loads and small control zones.

Valve control (water-side control)

The heating or cooling output of the heat exchanger is controlled by modifying the water flow.

Damper control (air-side control)

The heating or cooling output is controlled by modifying the flow of secondary air. Adjustable dampers guide the air current through the air cooler or the air heater or they divert the secondary air through a bypass avoiding the heat exchanger. The water flow remains constant.

Product range

All fan coil units are available in several sizes:

Type VKE in size 1100

Type VKH in sizes 630, 800, 1000 and 1250

Type VDC in size 1200

Type LVC in sizes 630, 800, 1000 and 1250

Accessories, special versions

(see brochure

"Accessories for LTG air-water systems")

- Units without secondary air filter and safety grille on the outlet (standard version with filter and grille)
- Condensate tray with drainage spigot
- For water-side unit connection: transition 1/2" or air bleed fitting, flexible connection hoses with or without venting
- Air outlet grille and frame
- Fresh air inlet through a nozzle tube
- Control accessories

Fan coil units for ceiling installation Type VKE

View of unit



Design

Ceiling fan coil unit VKE with two or four-pipe heat exchanger for a high capacity, made of copper pipe with press-fitted aluminium fins, for a maximum operating pressure of 10 bar, for connection to a cold and/or hot water system, with water-side control through high-precision valves.

Fan impeller made of plastic, inflammable according to UL 94 HB (non inflammable version on request).

Always insulated version for condensate formation during operation.

Fan features: safe starting, steady characteristic and low noise level, 6-pole single-phase motor with running capacitor.

Size 1100

Application

The ceiling fan coil unit type VKD is specifically designed for versatile application in hotels and office buildings and offers a wide range of possibilities for air distribution system designs.

Function

The fan draws in ambient air which is then led through a heat exchanger and discharged back into the room. The heat exchanger is fed with cold water for cooling and hot water for heating.

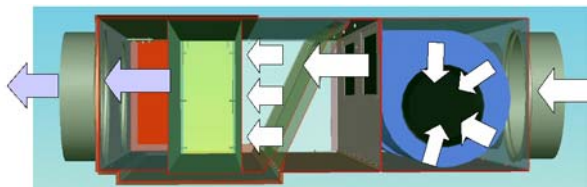

Function fan coil unit type VKE

Advantages

- LTG system with LTG air diffusers
- Individual adjustment of the cooling capacity
- Low-noise operation
- Low installation costs since all the components are factory-wired and integrated in the unit
- Energy efficient by optimisation controls
- Maintenance-friendly design

Fan coil units for ceiling installation Type VKE-2

Dimensions 2-pipe system, water connection left

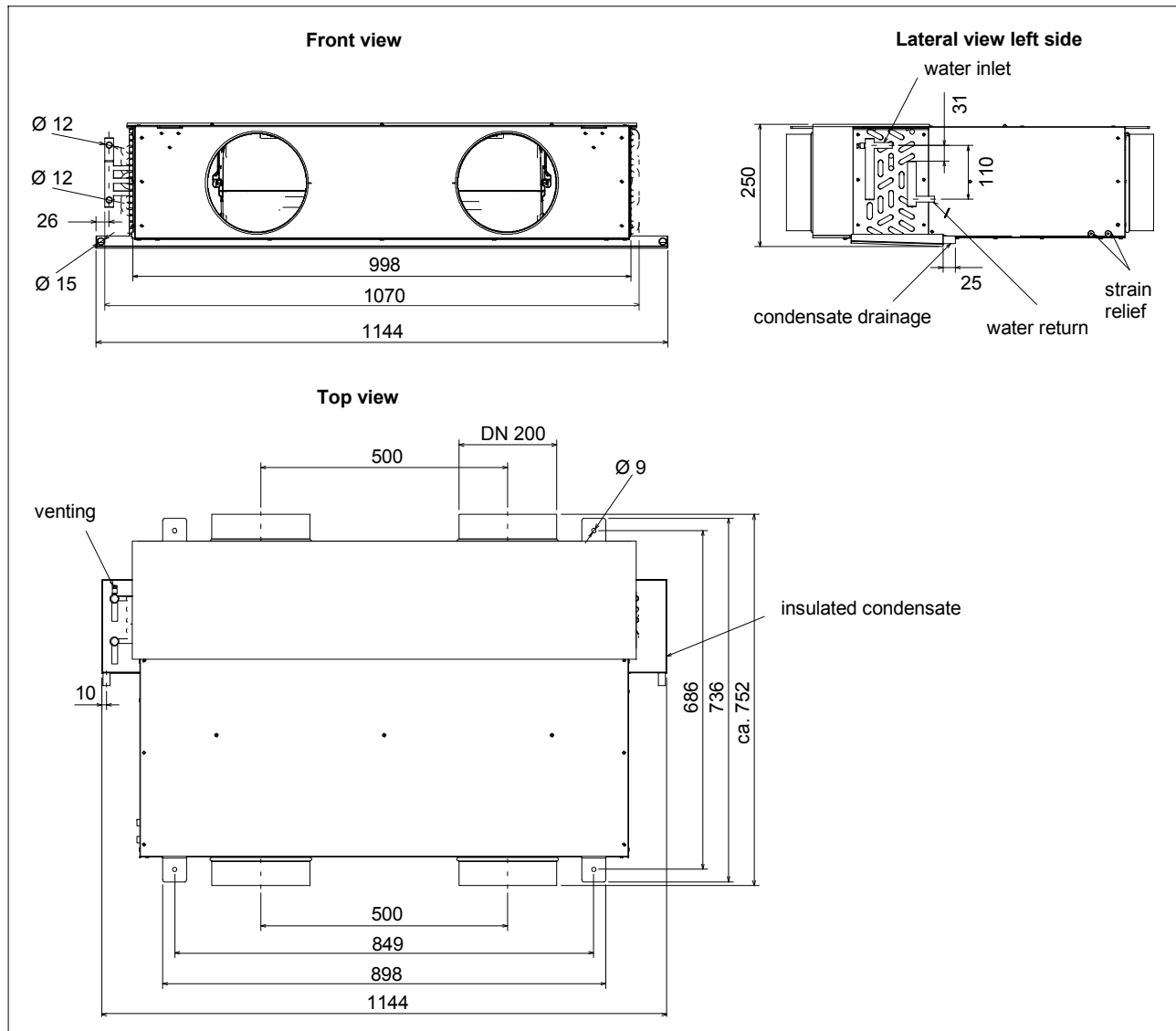

Fan coil units for ceiling installation Type VKE-2

Dimensions 2-pipe system, water connection right

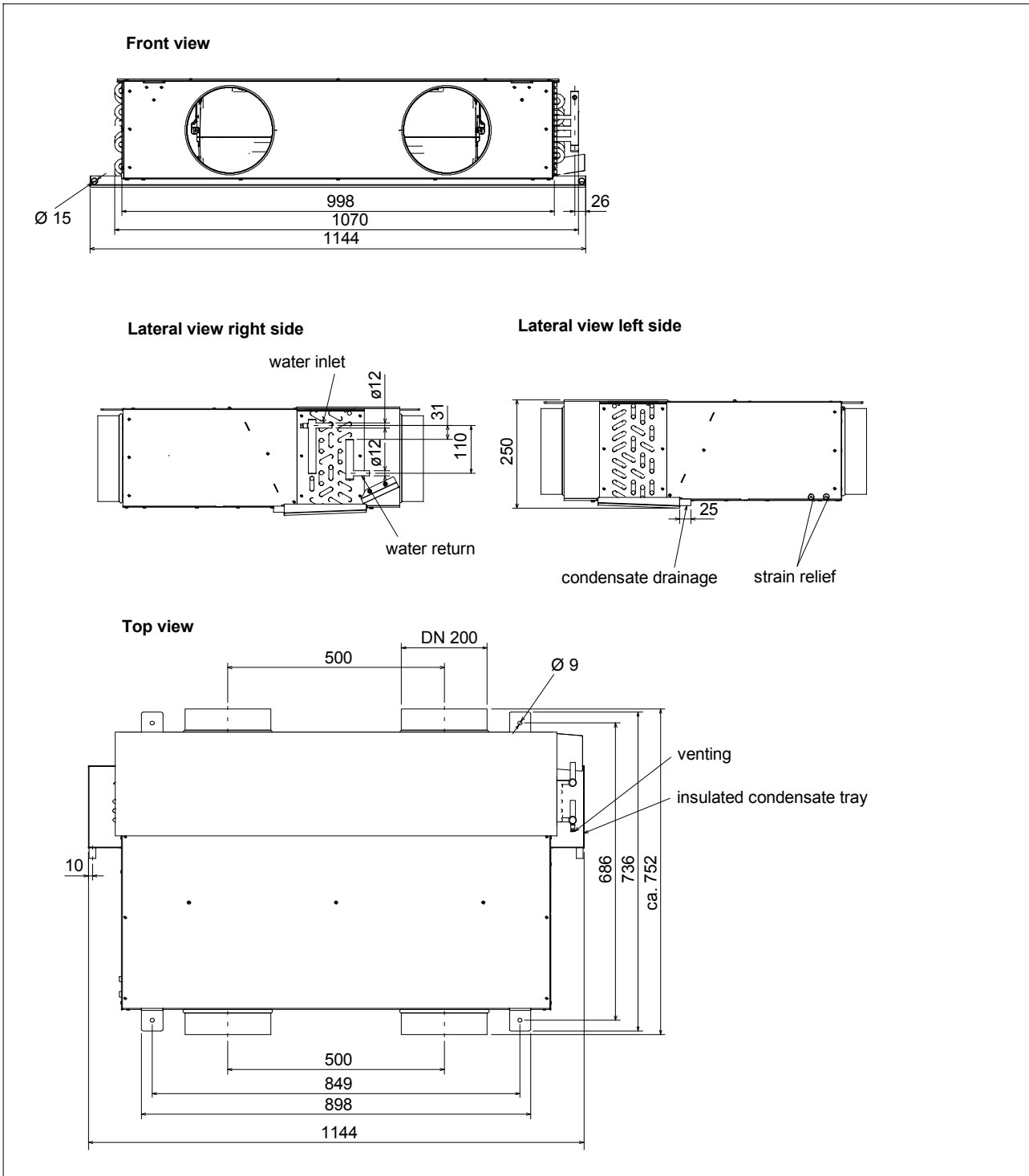

Fan coil units for ceiling installation Type VKE-4

Application 0-0, free suction, free discharge

Acoustics data without impact of ceiling, including diffuser insertion loss and flow noise (improved sound levels depending on the outlets' position in the ceiling and the ceiling's insulating properties). Weight: 42 kg.

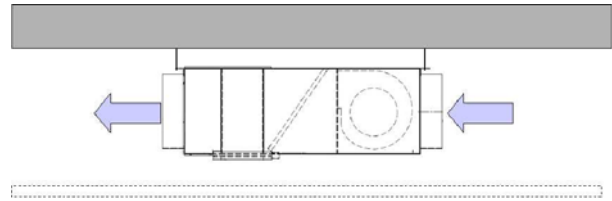

Technical data application 0-0, 4-pipe system

n [-]	Δp_{ext} [Pa]	V [m ³ /h]	L _{A18} [dB(A)]	L _{wA} [dB(A)]	Q _k / Δt [W/K]	Q _h / Δt [W/K]	w _{ok} / Δp _w [kg/h]/[kPa]	w _{oh} / Δp _w [kg/h]/[kPa]	P _{el} [W]
I	0	221	21	27	66	43	300/6	100/7	9
II		291	26	32	85	53			13
III		412	34	41	115	67			49
IV		569	43	50	149	77			60
V		728	49	55	178	79			75
I	10	136	25	32	42	28	300/6	100/7	9
II		224	29	35	67	44			13
III		357	35	42	102	61			47
IV		518	42	49	139	75			58
V		677	47	54	170	79			74
I	20	49	30	37	16	11	300/6	100/7	9
II		155	32	39	48	32			14
III		296	37	43	86	54			46
IV		462	42	49	126	71			57
V		620	47	54	159	79			72
II	30	84	35	42	27	18	300/6	100/7	14
III		231	39	45	69	45			44
IV		400	43	49	112	66			55
V		558	47	54	147	77			70
III	40	160	40	47	49	33	300/6	100/7	43
IV		332	44	50	96	58			54
V		490	47	54	133	73			69
III	50	84	42	48	27	18	300/6	100/7	41
IV		258	44	51	76	49			52
V		416	47	54	116	67			67
IV	60	179	45	52	54	36	300/6	100/7	50
V		337	47	54	97	59			65
IV	70	93	46	53	29	20	300/6	100/7	48
V		252	48	54	75	48			63
V	80	162	48	55	50	33	300/6	100/7	61
V	90	66	49	55	21	15	300/6	100/7	59

Legend see page 8

Fan coil units for ceiling installation Type VKE-4

Technical data condensing operation application 0-0

n [-]	Δp_{ext} [Pa]	V [m ³ /h]	L _{A18} [dB(A)]	L _{WA} [dB(A)]	Q _{k ges} [W]	Q _{k sens} [W]	Q _h / Δt [W/K]	w _{ok} / Δp_w [kg/h]/[kPa]	w _{oh} / Δp_w [kg/h]/[kPa]	P _{el} [W]	T _{outlet} [°C]
I	0	221	21	27	1975	1258	43	300/6	100/7	9	8.9
II		291	26	32	2379	1549	53			13	10.0
III		412	34	41	2873	1973	67			49	11.6
IV		569	43	50	3294	2451	77			60	13.1
V		728	49	55	3607	2907	79			75	14.0
I	10	136	25	32	1330	834	28	300/6	100/7	9	7.6
II		224	29	35	1994	1271	44			13	9.0
III		357	35	42	2675	1790	61			47	10.9
IV		518	42	49	3173	2300	75			58	12.7
V		677	47	54	3522	2767	79			74	13.7
I	20	49	30	37	514	323	11	300/6	100/7	9	6.4
II		155	32	39	1492	937	32			14	7.9
III		296	37	43	2406	1570	54			46	10.1
IV		462	42	49	3024	2130	71			57	12.2
V		620	47	54	3409	2603	79			72	13.4
II	30	84	35	42	860	538	18	300/6	100/7	14	6.8
III		231	39	45	2036	1300	45			44	9.1
IV		400	43	49	2833	1934	66			55	11.5
V		558	47	54	3269	2419	77			70	13.0
III	40	160	40	47	1530	962	33	300/6	100/7	43	8.0
IV		332	44	50	2572	1702	58			54	10.6
V		490	47	54	3101	2216	73			69	12.4
III	50	84	42	48	862	539	18	300/6	100/7	41	6.8
IV		258	44	51	2202	1417	49			52	9.5
V		416	47	54	2887	1987	67			67	11.7
IV	60	179	45	52	1674	1056	36	300/6	100/7	50	8,3
V		337	47	54	2594	1721	59			65	10.7
IV	70	93	46	53	947	592	20	300/6	100/7	48	7.0
V		252	48	54	2168	1393	48			63	9.4
V	80	162	48	55	1543	971	33	300/6	100/7	61	8.0
V	90	66	49	55	679	425	15	300/6	100/7	59	6.7

Legend

- n - speed
 Δp_{ext} - external pressure loss without filter and connection boxes
V - flow rate (approx. values, tolerance $\pm 10\%$)
L_{A18} - sound pressure level, 18 m² Sabine
L_{WA} - sound power level ± 3 dB(A) including suction-side, discharge-side, and structure-borne sounds
Q_{k tot} - total cooling capacity at 26 °C / 50 % rF and 6 °C cold water inlet temperature
Q_{k sens} - sensible cooling capacity at 26 °C / 50 % rF and 6 °C cold water inlet temperature

- Q_h - total heating capacity
 Δt - temperature difference between suction air temperature before entering the heat exchanger and water supply
w_{ok} - standard flow rate at cooling capacity
w_{oh} - standard flow rate at heating capacity
 Δp_w - water-side pressure loss
P_{el} - electric power consumption ($\pm 20\%$)

Speed control wiring diagram

(see page 15)

Fan coil units for ceiling installation Type VKE-4

Standard application DLA 7-0

Acoustics data without impact of ceiling, including DLA 7 insertion loss and diffuser flow noise (maximum improvement of sound levels ~ 2 dB depending on the outlets' position in the ceiling and the ceiling's insulating properties)

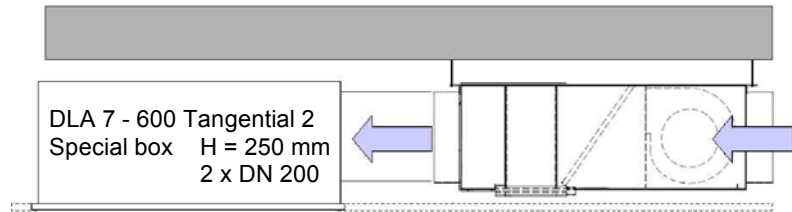

Technical data standard application DLA 7-0

n [-]	Pressure increase			L_{wA} [dB(A)]	V [m ³ /h]	P_{el} [W]	Q_k [W/K]	Q_h [W/K]
	Return air [Pa]	Supply air [Pa]	Δp [Pa]					
I	0	2.7	2.7	27	198	9	60	39
II	0	4.5	4.5	32	261	13	77	49
III	0	9.3	9.3	42	361	47	103	62
IV	0	17	17.0	49	479	57	130	72
V	0	26	26.0	54	584	71	152	78

Fan coil units for ceiling installation Type VKE-4

Standard application Z2-0, LDB 20/8/2 pressure side

Acoustics data without impact of ceiling, including diffuser insertion loss and flow noise (maximum improvement of sound levels ~ 2 dB depending on the outlets' position in the ceiling and the ceiling's insulating properties)

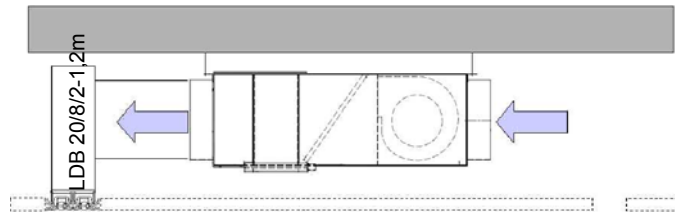

n [-]	Pressure increase			L _{WA} [dB(A)]	V [m ³ /h]	P _{el} [W]	Q _k [W/K]	Q _h [W/K]
	Return air [Pa]	Supply air [Pa]	Δp [Pa]					
I	0	5	5.0	29	179	9	54	36
II	0	8.5	8.5	35	234	13	70	45
III	0	16.8	16.8	44	316	46	92	57
IV	0	28.3	28.3	51	411	55	115	67
V	0	41.2	41.2	55	481	68	131	73

Standard application Z3-0, LDB 20/8/3 pressure side

Acoustics data without impact of ceiling, including diffuser insertion loss and flow noise (maximum improvement of sound levels ~ 2 dB depending on the outlets' position in the ceiling and the ceiling's insulating properties)

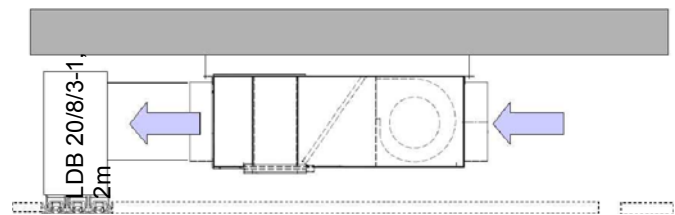

n [-]	Pressure increase			L _{WA} [dB(A)]	V [m ³ /h]	P _{el} [W]	Q _k [W/K]	Q _h [W/K]
	Return air [Pa]	Supply air [Pa]	Δp [Pa]					
I	0	2.6	2.6	28	199	9	60	40
II	0	4.9	4.9	33	258	13	77	49
III	0	9.5	9.5	42	359	46	102	62
IV	0	17.3	17.3	49	478	55	130	72
V	0	26.2	26.2	55	582	68	152	78

Standard application Z4-0, LDB 20/8/4 pressure side

Acoustics data without impact of ceiling, including diffuser insertion loss and flow noise (maximum improvement of sound levels ~ 2 dB depending on the outlets' position in the ceiling and the ceiling's insulating properties)

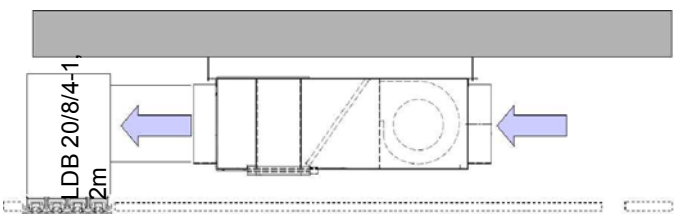

n [-]	Pressure increase			L _{WA} [dB(A)]	V [m ³ /h]	P _{el} [W]	Q _k [W/K]	Q _h [W/K]
	Return air [Pa]	Supply air [Pa]	Δp [Pa]					
I	0	1.7	1.7	28	207	9	62	41
II	0	3.2	3.2	33	270	13	80	50
III	0	5.9	5.9	44	380	46	107	64
IV	0	10.9	10.9	49	513	55	140	75
V	0	16.5	16.5	55	641	68	163	79

Fan coil units for ceiling installation Type VKE-4

Technical data standard application Z2-A2, LDB 20/8/2 pressure side, LDB 20/8/2 suction side

Since structure-borne sound is low. ceiling will not result in significant improvement of sound levels.

Acoustics data without impact of ceiling

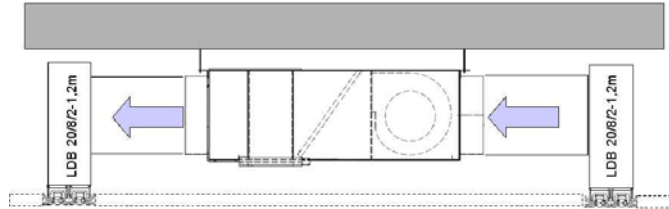

n [-]	Pressure increase			L _{WA} [dB(A)]	V [m ³ /h]	P _{el} [W]	Q _k [W/K]	Q _h [W/K]
	Return air [Pa]	Supply air [Pa]	Δp [Pa]					
I	-7.7	3.1	10.8	31	129	9	40	27
II	-12.9	6.1	19.0	37	162	13	50	33
III	-22.9	10.4	33.3	46	208	46	63	41
IV	-36.1	16.8	52.9	51	236	55	70	45
V	-47.3	22.1	69.4	55	257	68	76	49

Technical data standard application Z3-A3, LDB 20/8/3 pressure side, LDB 20/8/3 suction side

Since structure-borne sound is low. ceiling will not result in significant improvement of sound levels.

Acoustics data without impact of ceiling

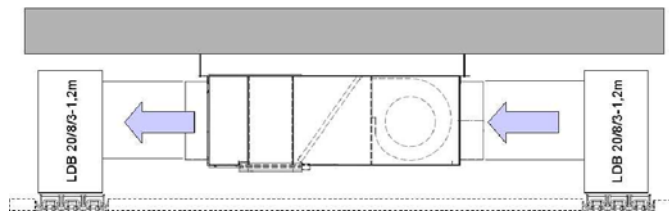

n [-]	Pressure increase			L _{WA} [dB(A)]	V [m ³ /h]	P _{el} [W]	Q _k [W/K]	Q _h [W/K]
	Return air [Pa]	Supply air [Pa]	Δp [Pa]					
I	-5.3	2.3	7.6	29	157	9	48	32
II	-8.5	3.6	12.1	35	210	13	63	41
III	-16.6	6.3	22.9	44	278	46	82	51
IV	-28.0	11.3	39.3	50	337	55	97	59
V	-39.2	15.5	54.7	54	380	68	107	64

Technical data standard application Z4-A4, LDB 20/8/4 pressure side, LDB 20/8/4 suction side

Since structure-borne sound is low. ceiling will not result in significant improvement of sound levels.

Acoustics data without impact of ceiling

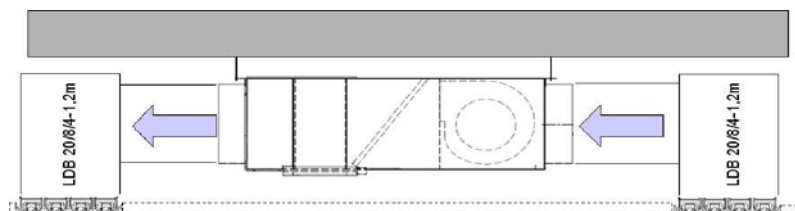

n [-]	Pressure increase			L _{WA} [dB(A)]	V [m ³ /h]	P _{el} [W]	Q _k [W/K]	Q _h [W/K]
	Return air [Pa]	Supply air [Pa]	Δp [Pa]					
I	-4.4	1.7	6.1	28	169	9	52	35
II	-6.9	2.7	9.6	33	227	13	68	44
III	-13.0	5.2	18.2	43	307	46	89	55
IV	-22.9	9.1	32.0	50	387	55	109	64
V	-33.3	13.1	46.4	55	443	68	122	70

Fan coil units for ceiling installation Type VKE-4

Cooling capacity for different water flow rates

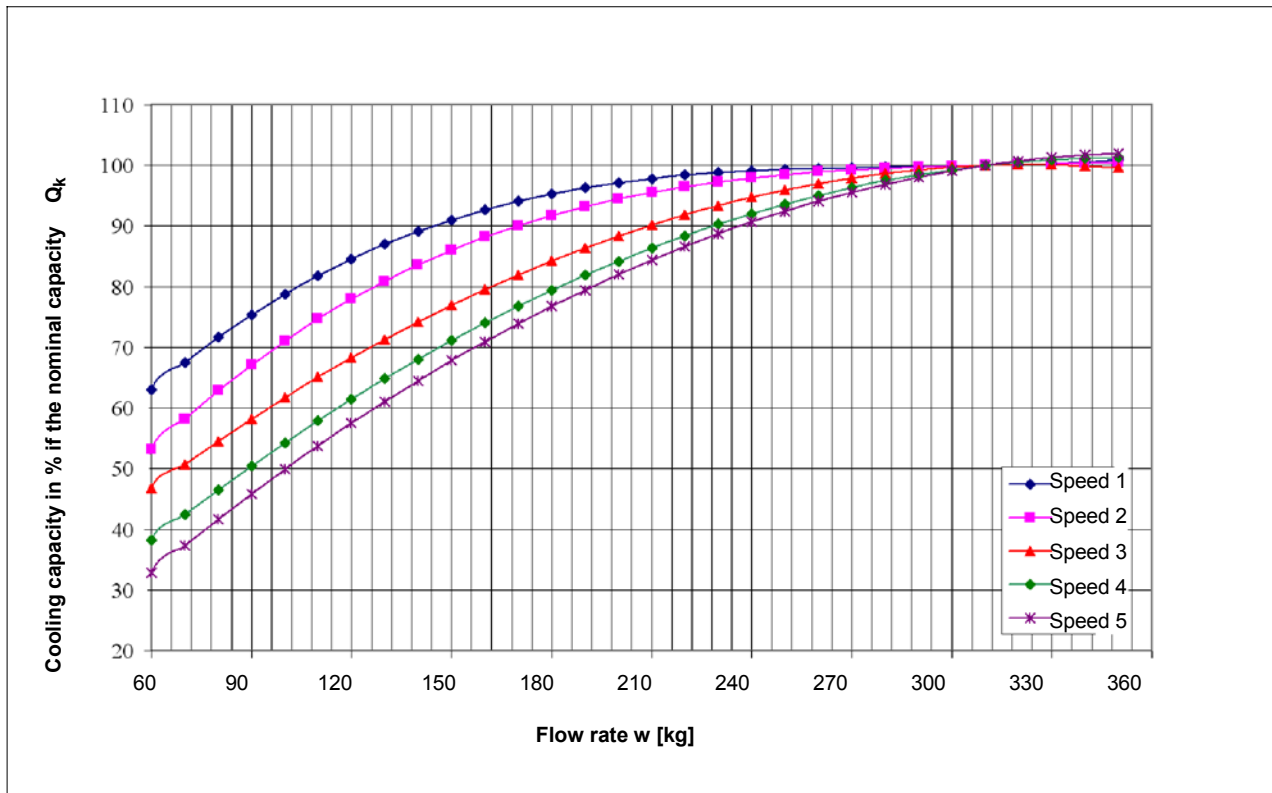

Heating capacity for different water flow rates

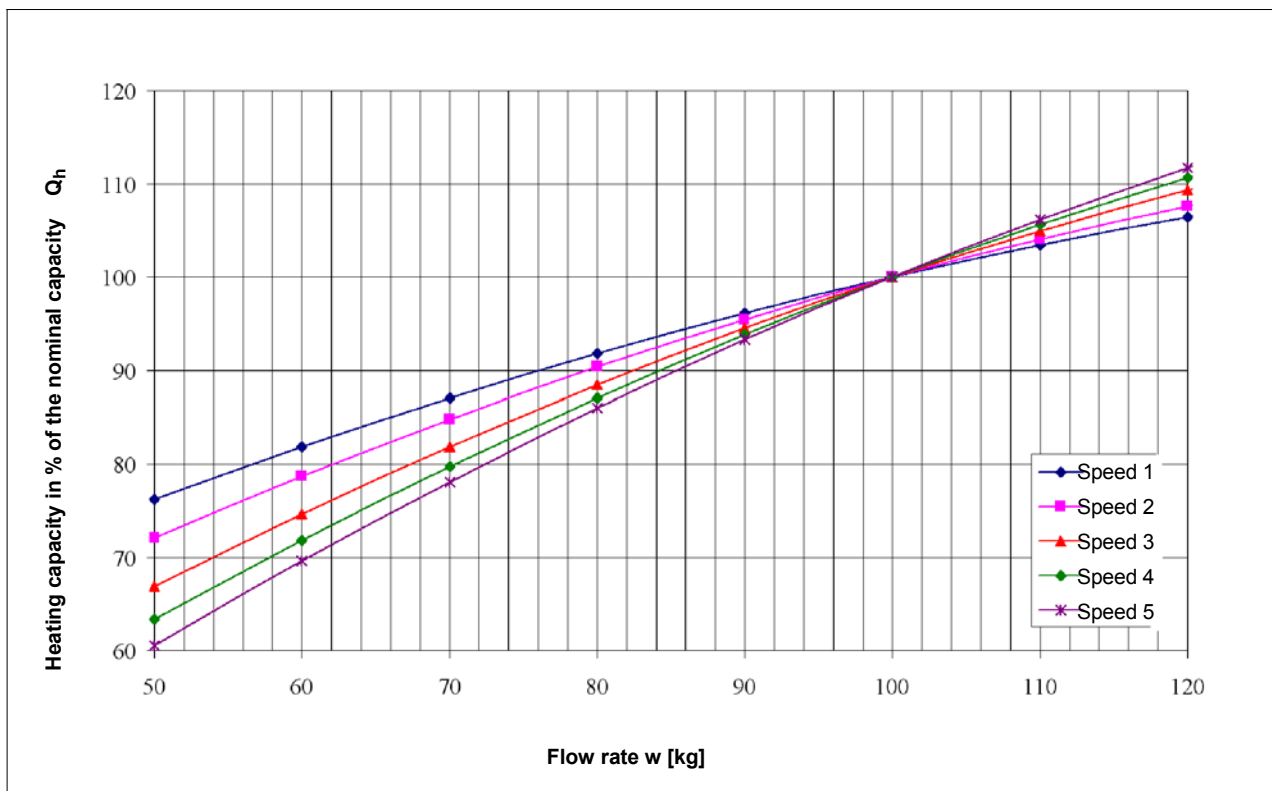

Fan coil units for ceiling installation Type VKE-2

Water-side pressure loss, 2-pipe system

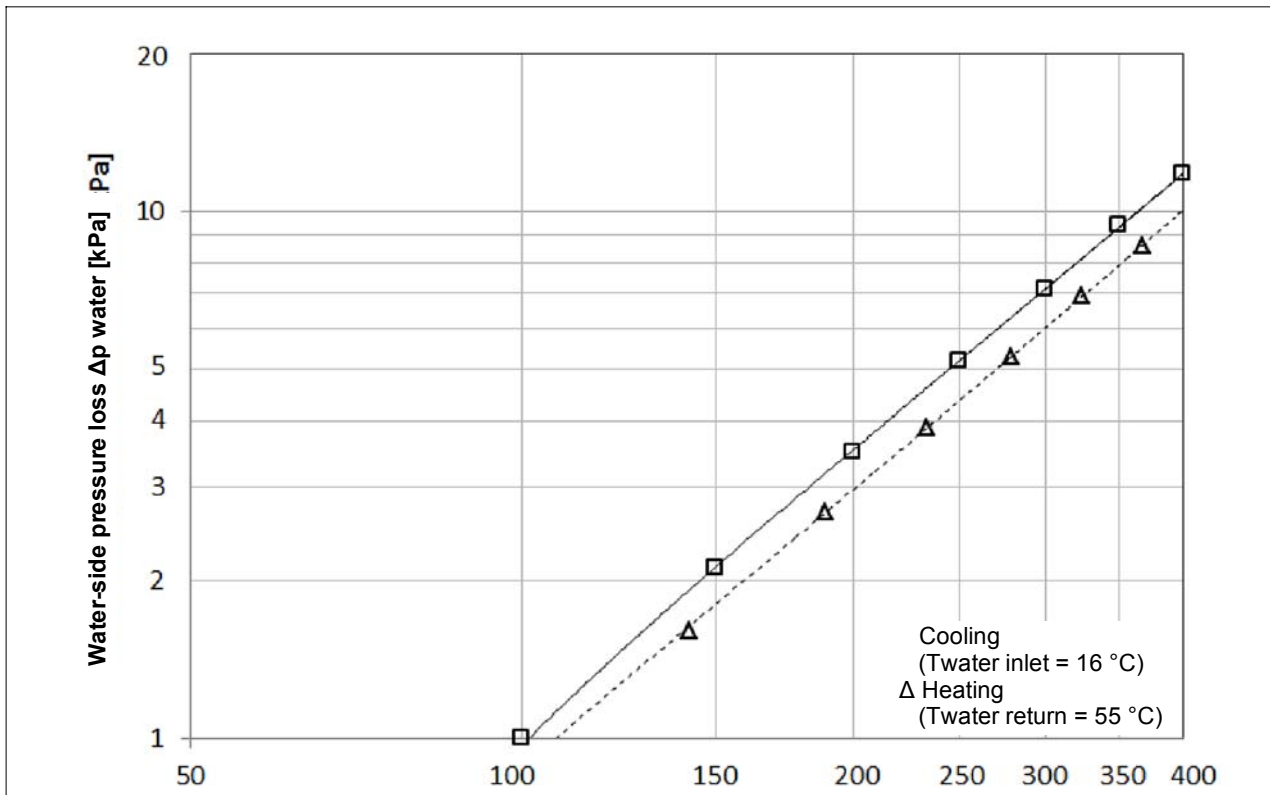

Data are valid with pipes, without transition pieces or collector.

Fan coil units for ceiling installation Type VKE-4

Installation

For installation on site the units are provided with 9 mm Ø through holes (fixing material by customer).

To avoid structure-borne sound transmission use vibration dampers when installing the unit and avoid any direct contact with ceiling elements.



1. Removal/cleaning of condensate tray



2. Replacement of plug-in filter



3. Removal of lower plate / vacuum-cleaning of heat exchanger on the pressure side

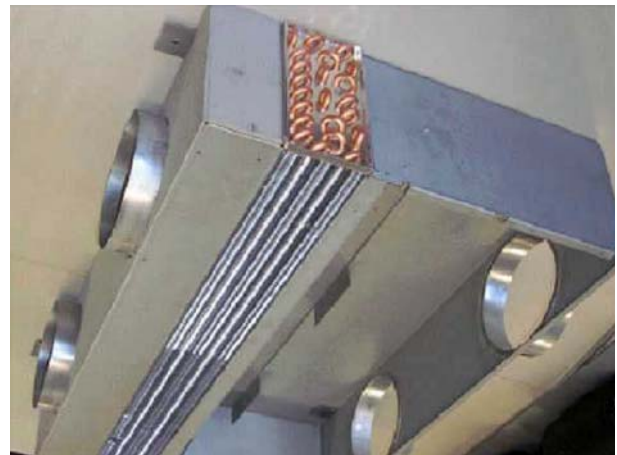

4. Removal of fan unit including mounting flange

Fan coil units for ceiling installation Type VKE-4

Speed control wiring diagram

Note: - 5-speed capacitor motor (internal switching of temperature controller)
 - group activation possible
 - for power consumption and output refer to technical data

A 2.3 m cable and mating connector are included in the delivery.

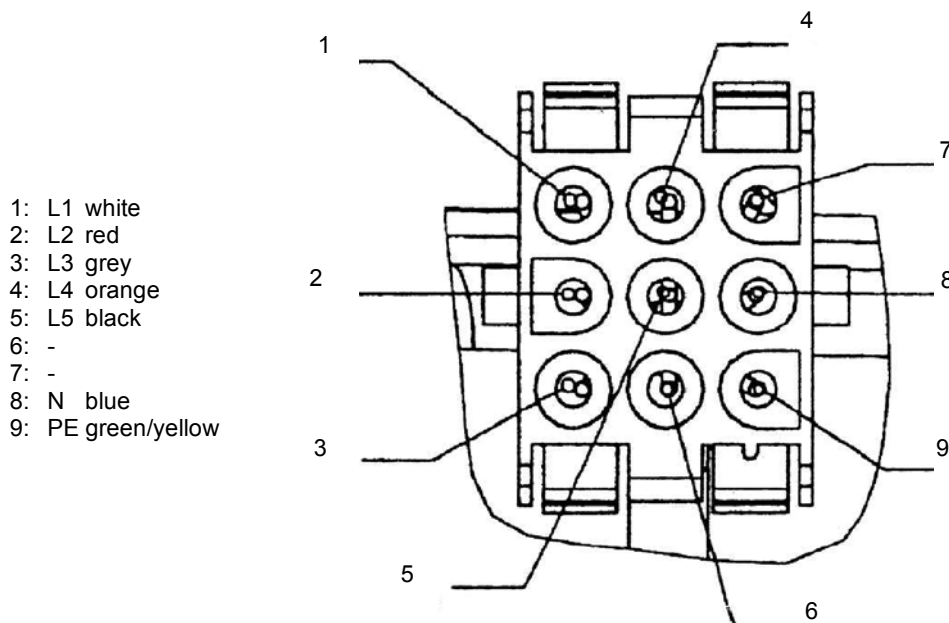
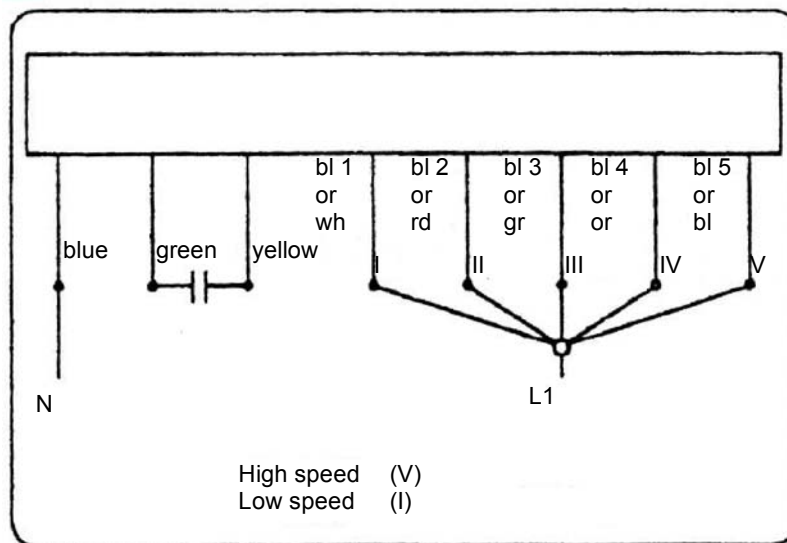

Fan coil units for ceiling installation Type VKE

Nomenclature

VKE - 2 / 1100 / F / R / 2A200 / 2A200 / OV
 (1) (2) (3) (4) (5) (6) (7) (8)

(1)	Series	VKE	= VKE
(2)	Heat exchanger	2 4	= 2-pipe = 4-pie
(3)	Size	1100	= 1100
(4)	Filter	F	= With filter
(5)	Water connetion	R L	= On the right = On the left
(6)	Pressure-side socket	2A200	= Number, Ø 200, round
(7)	Suction-side socket	2A200	= Number, Ø 200, round
(8)	Valve assembly	V2T OV	= 2-way, 2-point, loose = Without

Fan coil units for ceiling installation Type VKH Ventotel®

View of unit



Type VKH-4A 800 (4-pipe system)

Application

The ceiling fan coil unit type VKH is specifically designed for use in hotels. It offers versatile possibilities for design of air distribution systems.

Installation, position

The unit is made for installation in a ceiling bulkhead.

Function

The VKH's tangential fan draws air through the heating/cooling heat exchanger laterally and discharges it from the opposite side.

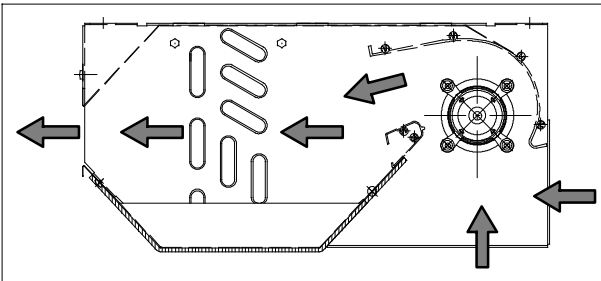

Operation principle VKH

Design

Ceiling fan coil unit type VKH:

- a 2-pipe system for cooling only or heating only (VKH-2A)
- a 4-pipe system for cooling and heating (VKH-4A)
- with attached primary air box (accessory)

Advantages

- Low-noise operation.
- Low installation height of only 218 mm.
- Easy access to the filter from below.
- Easy replacement of the filter.
- Insulation of the unit suitable for operation with 6 °C cooling water.
- Drain tray, 40 mm high, suitable for use in conjunction with condensate pump.
- Low water-side pressure loss
- Energy-saving fan operation
- Economic operation due to high water-side temperature difference (5 K)
- Primary air box may be attached to the unit. Thus, primary air and recirculating air may be discharged through the same grille.
- Maintenance-friendly design. Motor, impeller and heat exchanger are accessible from below.

Fan coil units for ceiling installation Type VKH Ventotel®

Dimensions 4-pipe system

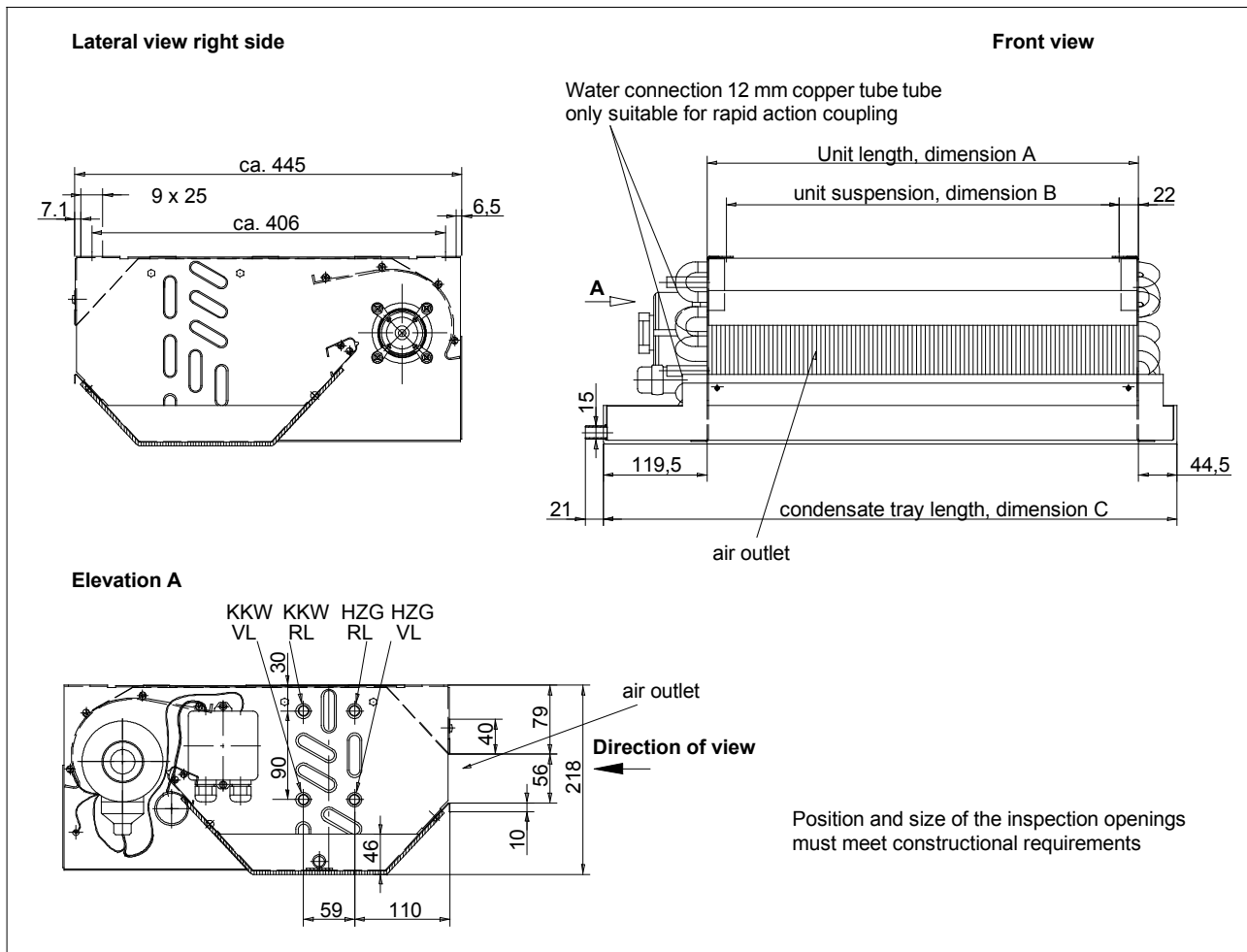

Illustrated unit: water connection on the left (on request: on the right). Motor always on the left (in direction of view)

Size	A [mm]	B [mm]	C [mm]	Weight [kg]
630	616	572	780	18
800	846	802	1010	23
1000	1046	1002	1210	28
1250	1246	1202	1410	33

KKW-VL = cooling - water inlet
 KKW-RL = cooling - water return
 HZG-VL = heating - water inlet
 HZG-RL = heating - water return

Fan coil units for ceiling installation Type VKH Ventotel®

Dimensions 2-pipe system

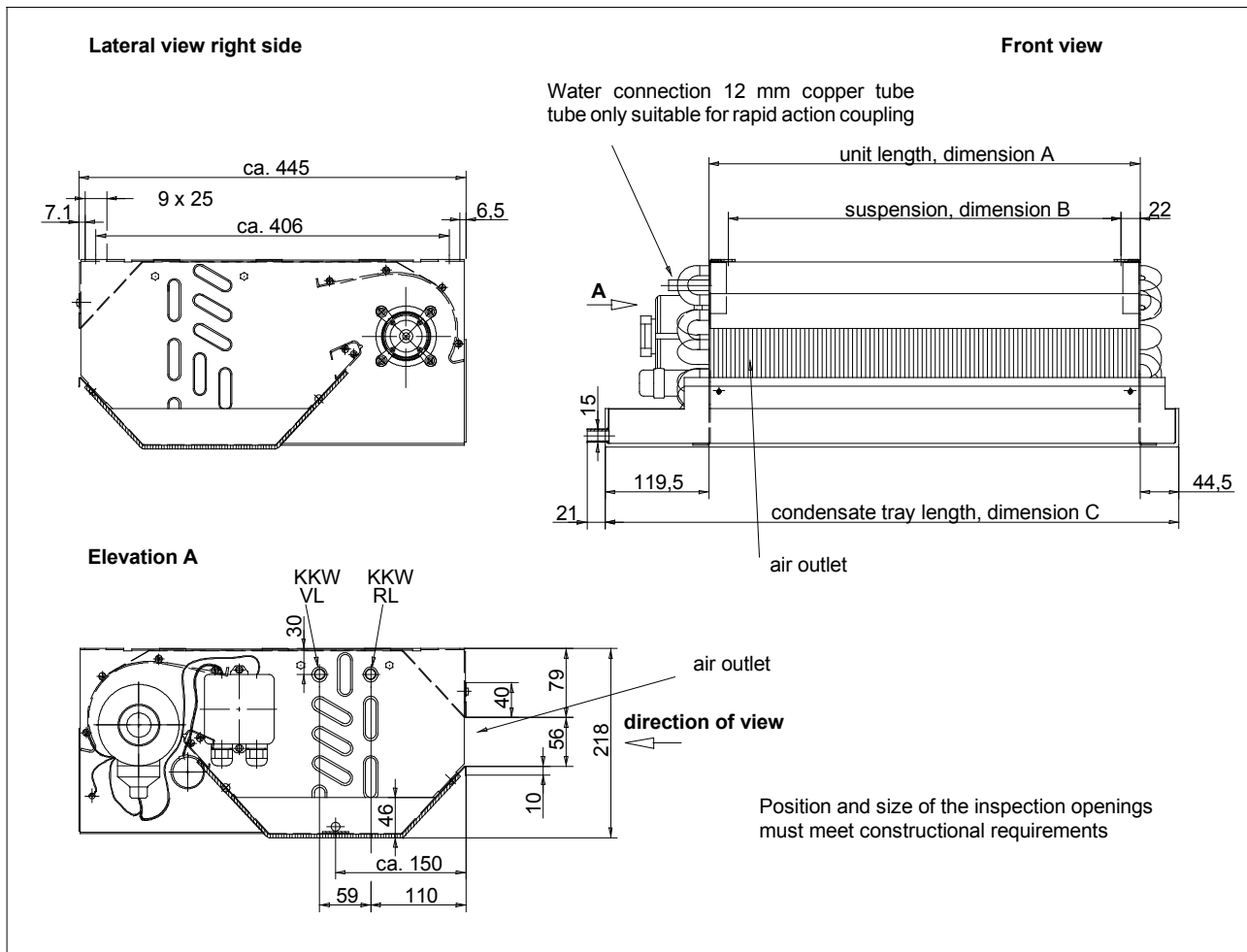

Illustrated unit: water connection on the left (on request: on the right). Motor always on the left (in direction of view)

Size	A [mm]	B [mm]	C [mm]	Weight [kg]
630	616	572	780	18
800	846	802	1010	23
1000	1046	1002	1210	28
1250	1246	1202	1410	33

KKW-VL = cooling - water inlet
 KKW-RL = cooling - water return

Fan coil units for ceiling installation Type VKH Ventotel®

Accessories, special versions

- straight-way valve with three-position actuator (24 V)
- straight-way valve with electro-thermal actuator
- three-step switch (OFF / 3 / 2 / 1)
- easy-to-replace, self-extinguishing filter
- Fresh air box (on the water connection's opposite side)

Dimensions fresh air box

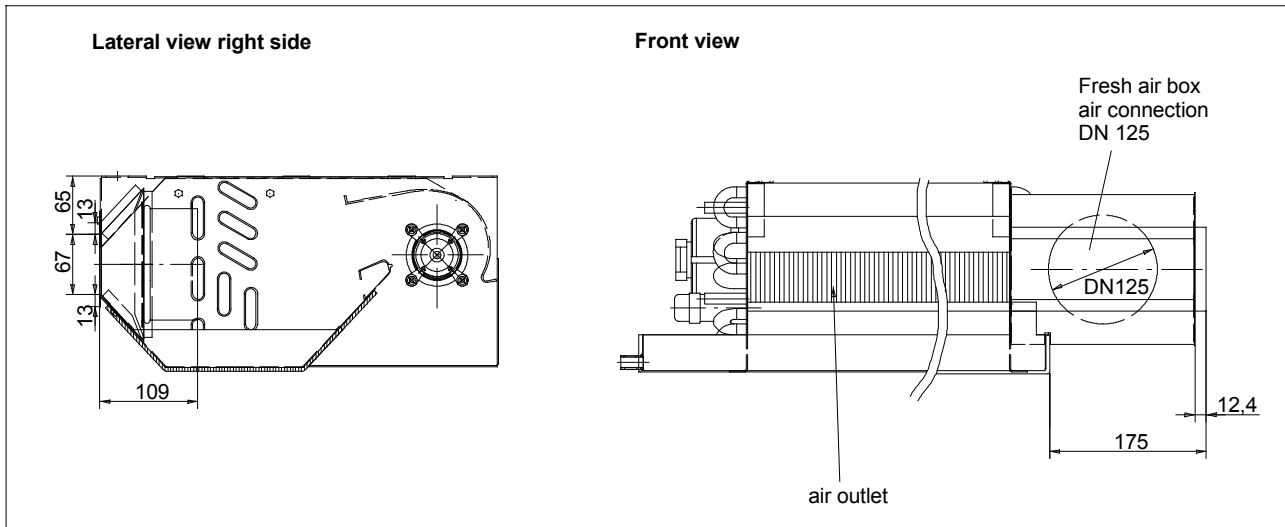

All other dimensions

see page 18 (2-pipe system)

see page 19 (4-pipe system)

Fan coil units for ceiling installation Type VKH Ventotel®

Technical data size 630 - 4-pipe system - heating and cooling

n [-]	V [m ³ /h]	L _{A18} [dB(A)]	L _{wA} [dB(A)]	Q _k /Δt ¹⁾ [W/K]	Q _k ²⁾ [W]	Q _{k sens} ²⁾ [W]	w _{ok} / Δp _w [kg/h]/[kPa]	Q _h /Δt [W/K]	Q _h ³⁾ [W]	w _{oh} / Δp _w [kg/h]/[kPa]	P _{el} [W]	I _{max} [mA]
I	160	24	30	43	1032	728	250 / 9.6	26	1040	100 / 0.8	22	170
II	235	30	36	56	1344	1070		32	1280		26	
III	310	34	40	66	1492	1245		35	1400		28	
IV	390	39	45	73	1606	1394		38	1520		32	
V	495	46	52	83	1793	1668		41	1640		39	

Technical data size 800 - 4-pipe system - heating and cooling

n [-]	V [m ³ /h]	L _{A18} [dB(A)]	L _{wA} [dB(A)]	Q _k /Δt ¹⁾ [W/K]	Q _k ²⁾ [W]	Q _{k sens} ²⁾ [W]	w _{ok} / Δp _w [kg/h]/[kPa]	Q _h /Δt [W/K]	Q _h ³⁾ [W]	w _{oh} / Δp _w [kg/h]/[kPa]	P _{el} [W]	I _{max} [mA]
I	191	22	28	51	1226	865	250 / 12.2	31	1240	100 / 1	22	170
II	274	28	34	66	1611	1281		37	1480		26	
III	368	33	39	78	1771	1478		40	1600		28	
IV	457	38	44	86	1889	1639		42	1680		32	
V	582	46	52	98	2120	1974		46	1840		39	

Technical data size 1000 - 4-pipe system - heating and cooling

n [-]	V [m ³ /h]	L _{A18} [dB(A)]	L _{wA} [dB(A)]	Q _k /Δt ¹⁾ [W/K]	Q _k ²⁾ [W]	Q _{k sens} ²⁾ [W]	w _{ok} / Δp _w [kg/h]/[kPa]	Q _h /Δt [W/K]	Q _h ³⁾ [W]	w _{oh} / Δp _w [kg/h]/[kPa]	P _{el} [W]	I _{max} [mA]
I	220	24	30	60	1426	1005	250 / 14.8	36	1440	100 / 1.2	22	180
II	330	30	36	78	1891	1504		44	1760		27	
III	430	36	42	91	2069	1727		47	1880		29	
IV	535	42	48	102	2243	1947		50	2000		33	
V	680	47	53	115	2484	2313		54	2160		39	

Technical data size 1250 - 4-pipe system - heating and cooling

n [-]	V [m ³ /h]	L _{A18} [dB(A)]	L _{wA} [dB(A)]	Q _k /Δt ¹⁾ [W/K]	Q _k ²⁾ [W]	Q _{k sens} ²⁾ [W]	w _{ok} / Δp _w [kg/h]/[kPa]	Q _h /Δt [W/K]	Q _h ³⁾ [W]	w _{oh} / Δp _w [kg/h]/[kPa]	P _{el} [W]	I _{max} [mA]
I	265	24	30	70	1678	1183	250 / 17.8	42	1680	100 / 1.5	22	180
II	395	31	37	93	2241	1782		52	2080		27	
III	505	36	42	108	2441	2037		56	2240		29	
IV	625	41	47	122	2685	2330		60	2400		33	
V	800	47	53	136	2940	2737		64	2560		39	

Values are given for the unit without ceiling coffer but including the filter and the air outlet grille, 8 W motor.

1) Water inlet: 16 °C; suction air temperature before entering the heat exchanger: 26 °C; non condensing operation.

2) Water inlet: 6 °C; suction air temperature before entering the heat exchanger: 26 °C; relative air humidity: 50 %.

3) Water inlet: 60 °C; suction air temperature before entering the heat exchanger: 20 °C

Legend

- n - speed
V - flow rate (approx. values, tolerance ± 10%)
L_{A18} - sound pressure level, 18 m² Sabine
L_{wA} - sound power level ± 3 dB(A) (without casing)
Δt - temperature difference between suction air temperature before entering the heat exchanger and water supply
Q_k - total cooling capacity
Q_{k sens} - sensible cooling capacity

- w_{ok} - standard flow rate at cooling capacity*
Δp_w - water-side pressure loss
Q_h - total heating capacity
w_{oh} - standard flow rate at heating capacity*
P_{el} - electric power consumption (± 20%)
I_{max} - maximum current input at speed V

*correction for other flow rates see page 23 ff

Speed control wiring diagram

See page 47

Fan coil units for ceiling installation Type VKH Ventotel®

Technical data size 630 - 2-pipe system - heating or cooling

n [-]	V [m ³ /h]	L _{A18} [dB(A)]	L _{WA} [dB(A)]	Q _k / Δt ¹⁾ [W/K]	Q _k ²⁾ [W]	Q _{k sens} ²⁾ [W]	Q _h ³⁾ [W]	w _{ok} / Δp _w [kg/h]/[kPa]	P _{el} [W]	I _{max} [mA]
I	160	24	30	45	1080	762	1800	250 / 13.5	22	170
II	235	30	36	59	1416	1127	2360		26	
III	310	34	40	69	1559	1305	2760		28	
IV	390	39	45	79	1738	1509	3160		32	
V	495	46	52	90	1944	1808	3600		39	

Technical data size 800 - 2-pipe system - heating or cooling

n [-]	V [m ³ /h]	L _{A18} [dB(A)]	L _{WA} [dB(A)]	Q _k / Δt ¹⁾ [W/K]	Q _k ²⁾ [W]	Q _{k sens} ²⁾ [W]	Q _h ³⁾ [W]	w _{ok} / Δp _w [kg/h]/[kPa]	P _{el} [W]	I _{max} [mA]
I	188	24	30	53	1274	988	2120	250 / 17	22	170
II	269	30	36	69	1662	1385	2760		26	
III	350	34	40	82	1868	1596	3280		28	
IV	426	39	45	93	2034	1800	3720		32	
V	540	46	52	106	2293	2143	4240		39	

Technical data size 1000 - 2-pipe system - heating or cooling

n [-]	V [m ³ /h]	L _{A18} [dB(A)]	L _{WA} [dB(A)]	Q _k / Δt ¹⁾ [W/K]	Q _k ²⁾ [W]	Q _{k sens} ²⁾ [W]	Q _h ³⁾ [W]	w _{ok} / Δp _w [kg/h]/[kPa]	P _{el} [W]	I _{max} [mA]
I	188	24	30	53	1274	988	2120	250 / 17	22	170
II	269	30	36	69	1662	1385	2760		26	
III	350	34	40	82	1868	1596	3280		28	
IV	426	39	45	93	2034	1800	3720		32	
V	540	46	52	106	2293	2143	4240		39	

Technical data size 1250 - 2-pipe system - heating or cooling

n [-]	V [m ³ /h]	L _{A18} [dB(A)]	L _{WA} [dB(A)]	Q _k / Δt ¹⁾ [W/K]	Q _k ²⁾ [W]	Q _{k sens} ²⁾ [W]	Q _h ³⁾ [W]	w _{ok} / Δp _w [kg/h]/[kPa]	P _{el} [W]	I _{max} [mA]
I	265	24	30	73	1752	1235	2920	250 / 26	22	180
II	395	31	37	97	2328	1852	3880		27	
III	505	36	42	113	2554	2131	4520		29	
IV	625	41	47	132	2904	2520	5280		33	
V	800	47	53	147	3175	2955	5880		39	

Values are given for the unit without ceiling coffer but including the filter and the air outlet grille, 8 W motor.

1) Water inlet: 16 °C; suction air temperature before entering the heat exchanger: 26 °C; non condensing operation.

2) Water inlet: 6 °C; suction air temperature before entering the heat exchanger: 26 °C; relative air humidity: 50 %.

3) Water inlet: 60 °C; suction air temperature before entering the heat exchanger: 20 °C

Legend

n	- speed	w _{ok}	- standard flow rate at cooling capacity *
V	- flow rate (approx. values, tolerance ± 10 %)	Δp _w	- water-side pressure loss
L _{A18}	- sound pressure level, 18 m ² Sabine	Q _h	- total heating capacity
L _{WA}	- sound power level ± 3 dB(A) (without casing)	P _{el}	- electric power consumption (± 20 %)
Δt	- temperature difference between suction air temperature before entering the heat exchanger and water supply	I _{max}	- maximum current input at speed V
Q _k	- total cooling capacity		
Q _{k sens}	- sensible cooling capacity		

* correction for other flow rates see page 23 ff

Speed control wiring diagram

See page 47

Fan coil units for ceiling installation Type VKH Ventotel®

Cooling capacity for different water flow rates, 4-pipe system

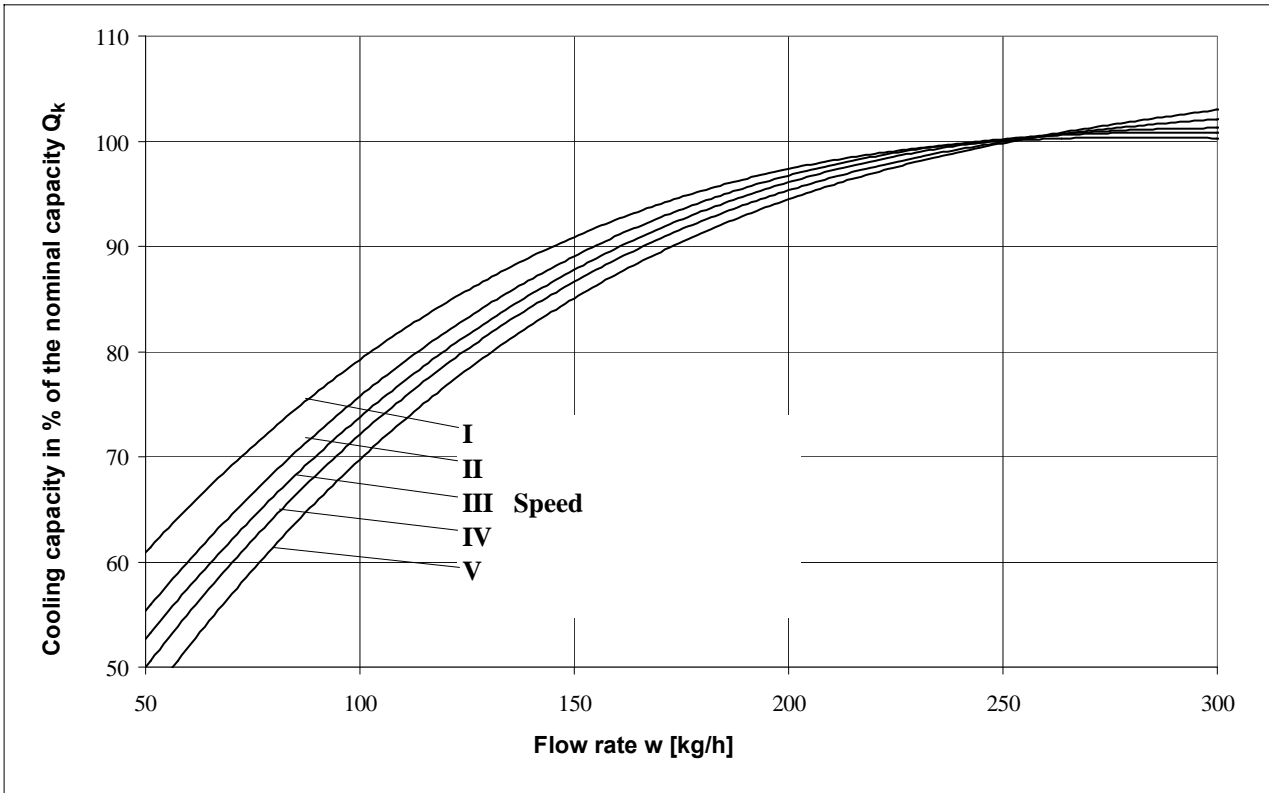

Water-side pressure loss of the cooler for different water flow rates,, 4-pipe system

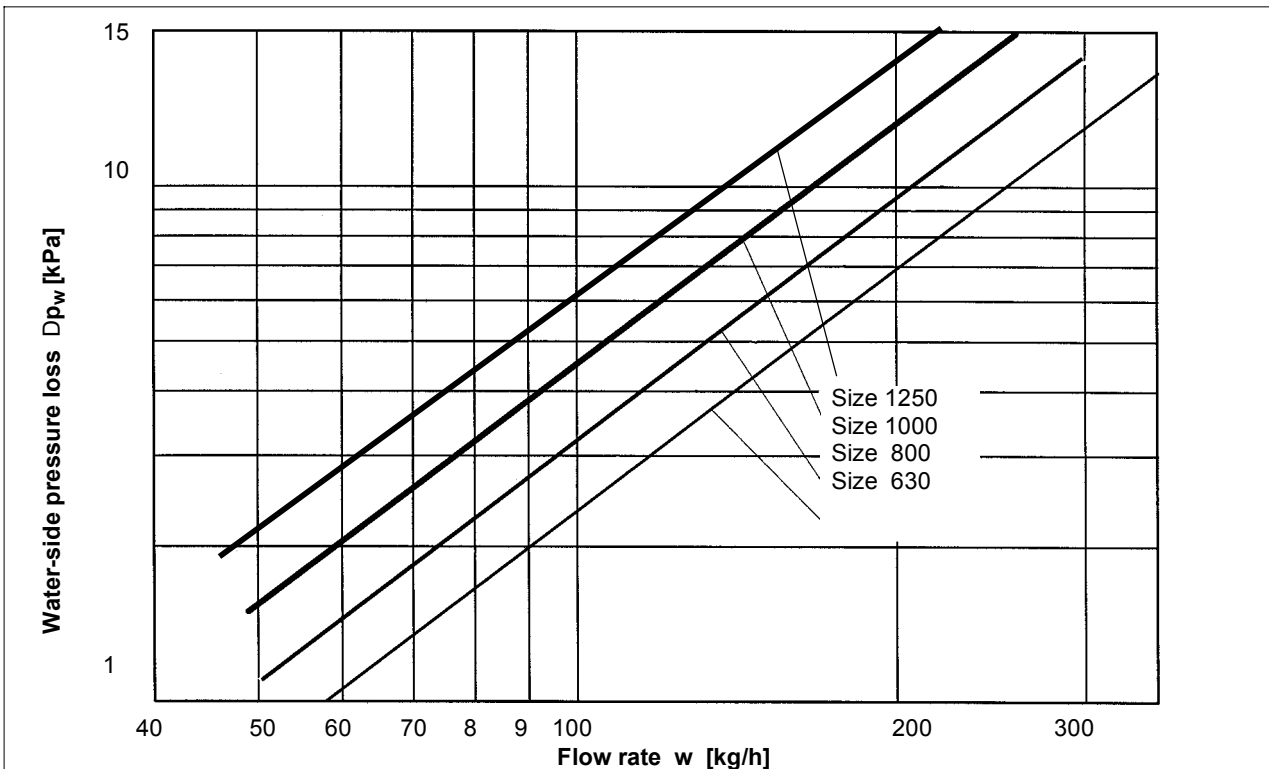

Fan coil units for ceiling installation Type VKH Ventotel®

Heating capacity for different water flow rates, 4-pipe system

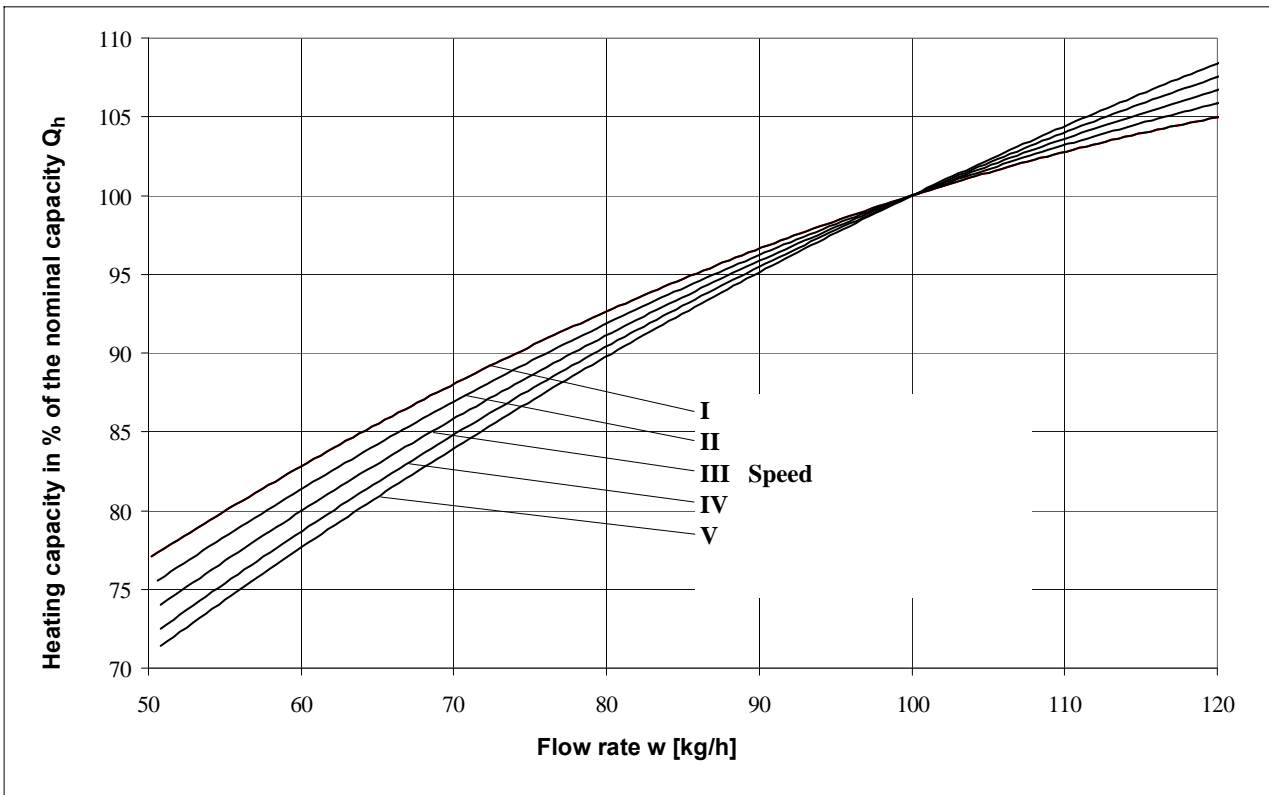

Water-side pressure loss of the heater for different water flow rates, 4-pipe system

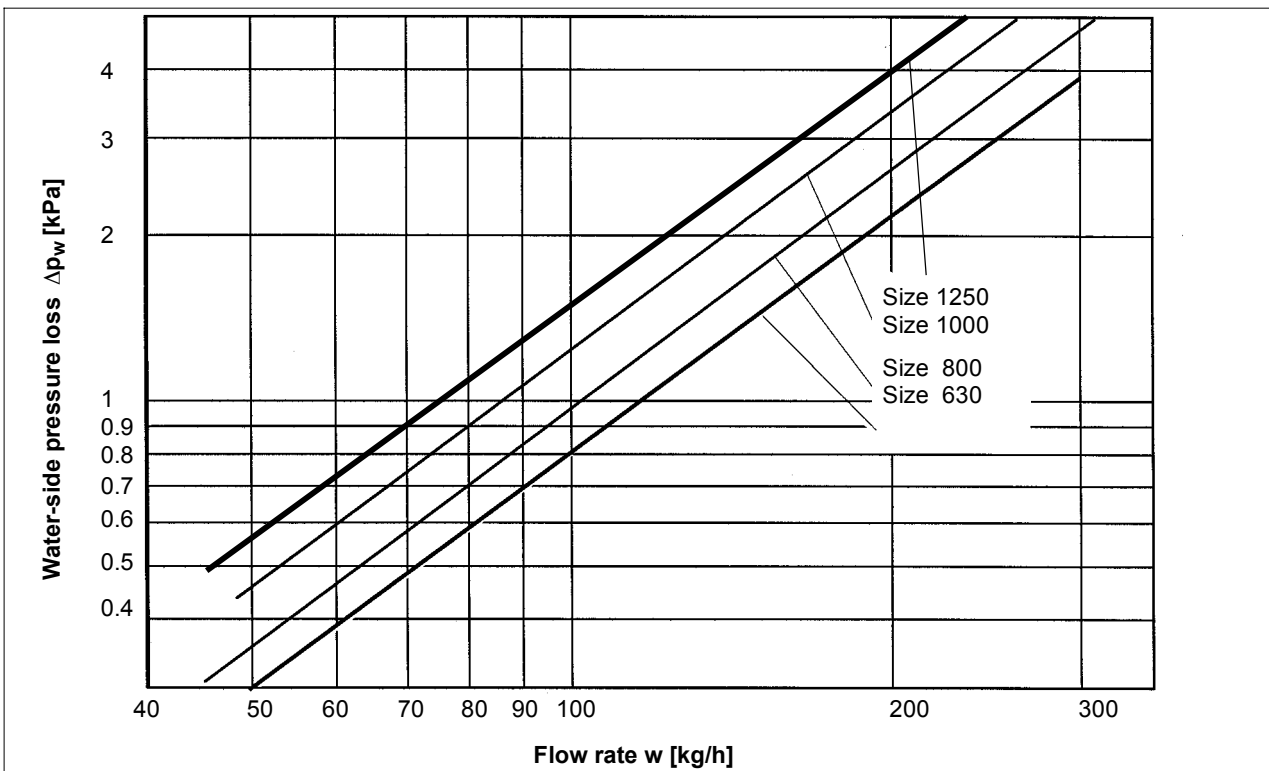

Fan coil units for ceiling installation Type VKH Ventotel®

Cooling capacity for different water flow rates, 2-pipe system

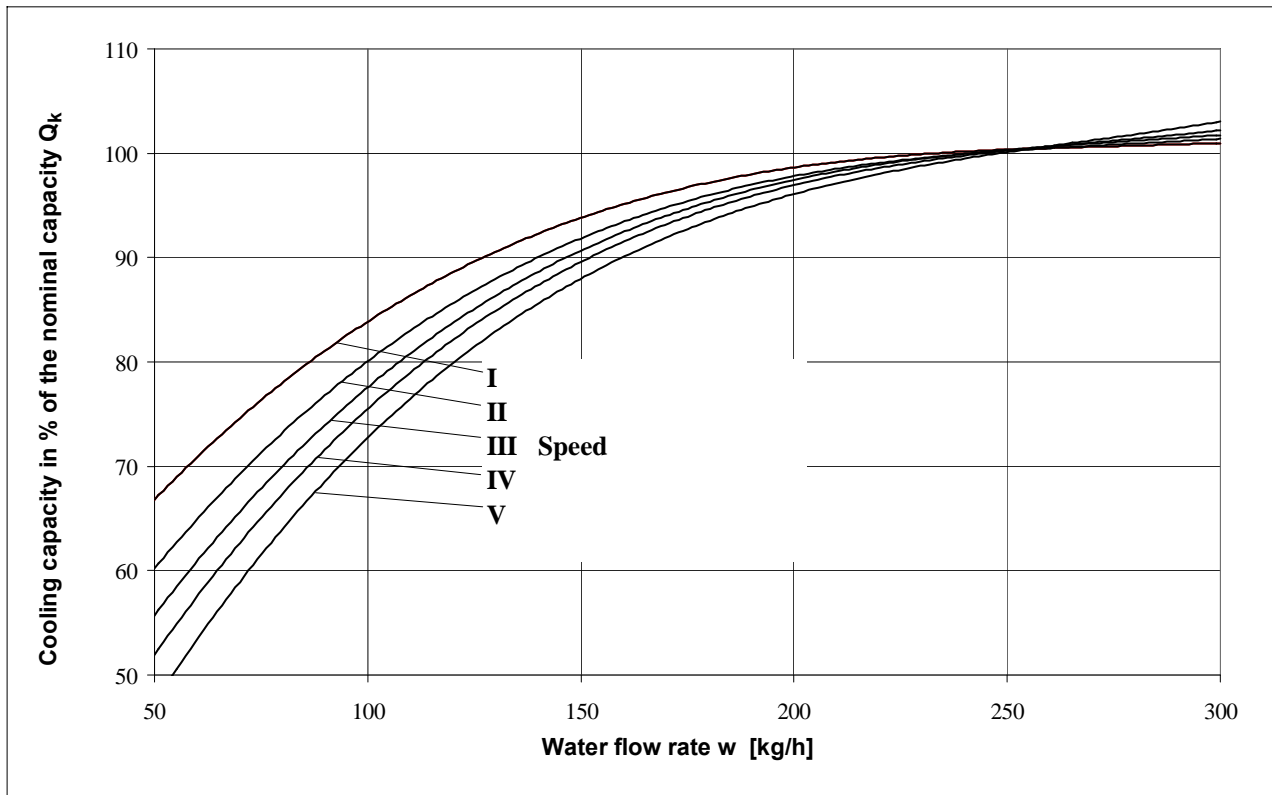

Water-side pressure loss of the cooler for different water flow rates, 2-pipe system

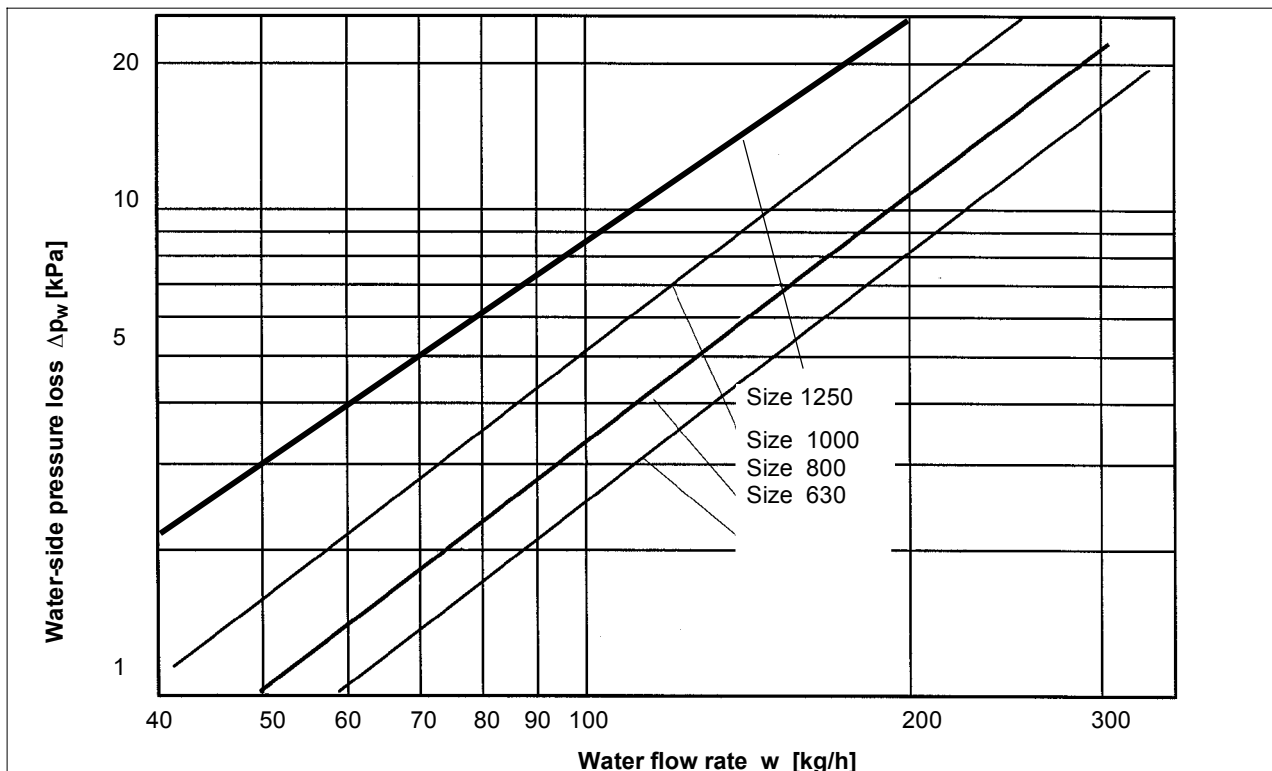

Fan coil units for ceiling installation Type VKH Ventotel®

Nomenclature

VKH - 2 / 800 / 5 / R / O / R

(1) (2) (3) (4) (5) (6) (7)

- | | | | |
|-----|-------------------------|--|------------------------------------|
| (1) | Series | VKH | = VKH |
| (2) | Heat exchanger | 2
4 | = 2-pipe
= 4-pipe |
| (3) | Size | 630
800
1000
1250 | = 630
= 800
= 1000
= 1250 |
| (4) | Motor | 5
EC | = 5 speeds
= EC Motor |
| (5) | Water connection | R
L | = on the right
= on the left |
| (6) | Fresh air | O
M | = without
= with |
| (7) | Air connection | R
L | = on the right
= on the left |

Fan coil units for ceiling installation Type VDC

Views of unit



2-pipe system



View from below

Application

The ceiling fan coil unit Type VDC is specifically designed for installation in false ceilings. In the cooling mode room air is heated at the façade, entrained into the unit, cooled and recirculated to the space.

Function

The fan draws room air from the facade area and passes this through the heat exchanger. This air is then passed through the adjacent slot diffuser. The conditioned supply air is discharged underneath of the unit into the room. There is no need for an additional return air grille.

Versions

The ceiling fan coil unit Type VDC model 1200 is available as a 2-pipe system for cooling or heating.

Advantages

- Low installation height (240 mm)
- Attractive design of the combined air intake/outlet grille, colours according to RAL, flanged or recessed installation.
- High thermal comfort in the occupied zone
- Maintenance-free design. Valves and heat exchanger are easily accessible by removing the grille.
- Energy efficient by use of low primary flow rates and low static pressure at the primary air duct
- Virtually noiseless operation

Fan coil units for ceiling installation Type VDC

Dimensions flanged installation, 2-pipe system

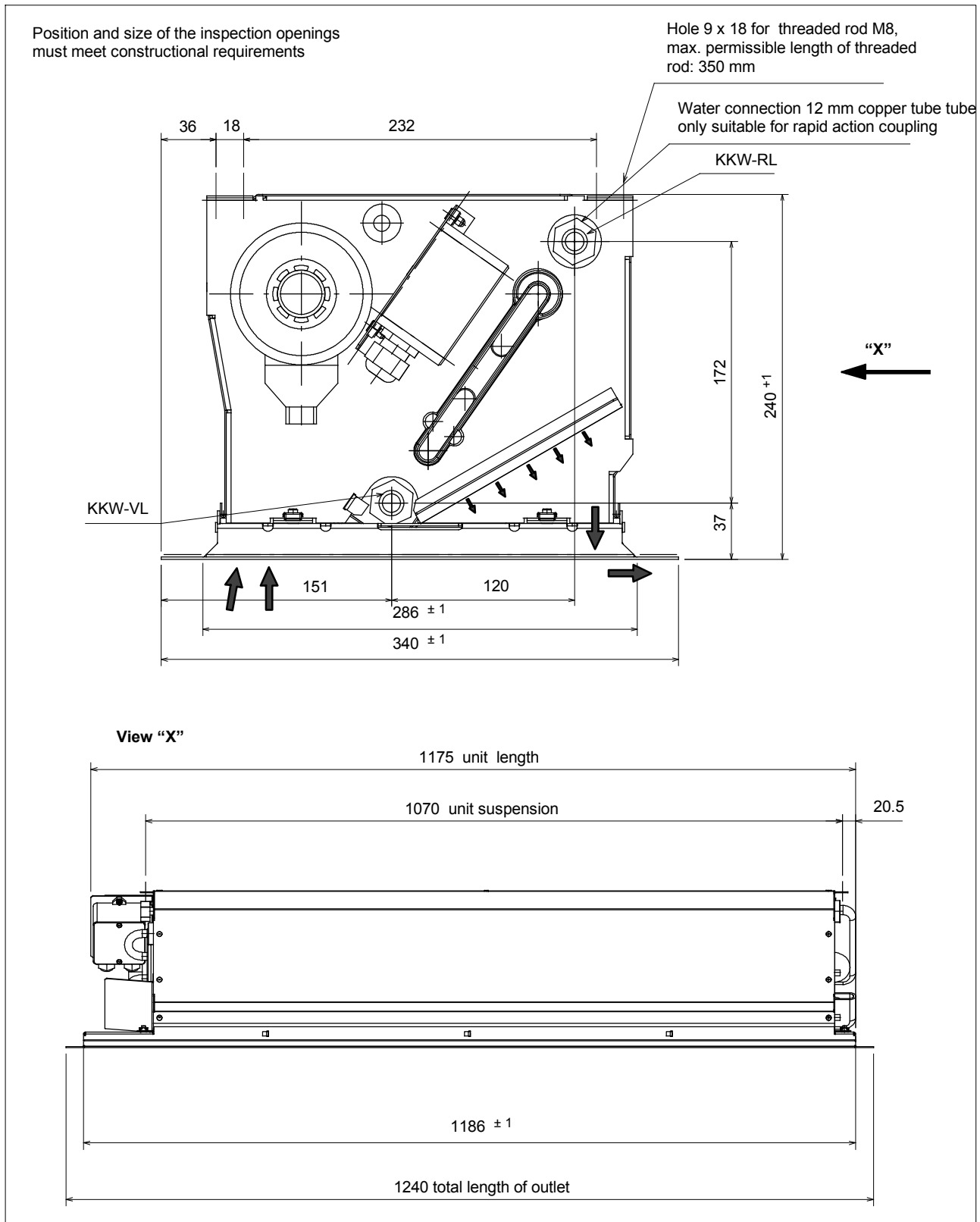

KKW-VL = cooling - water inlet KKW-RL = cooling - water return

Fan coil units for ceiling installation Type VDC

Dimensions recessed installation, 2-pipe system

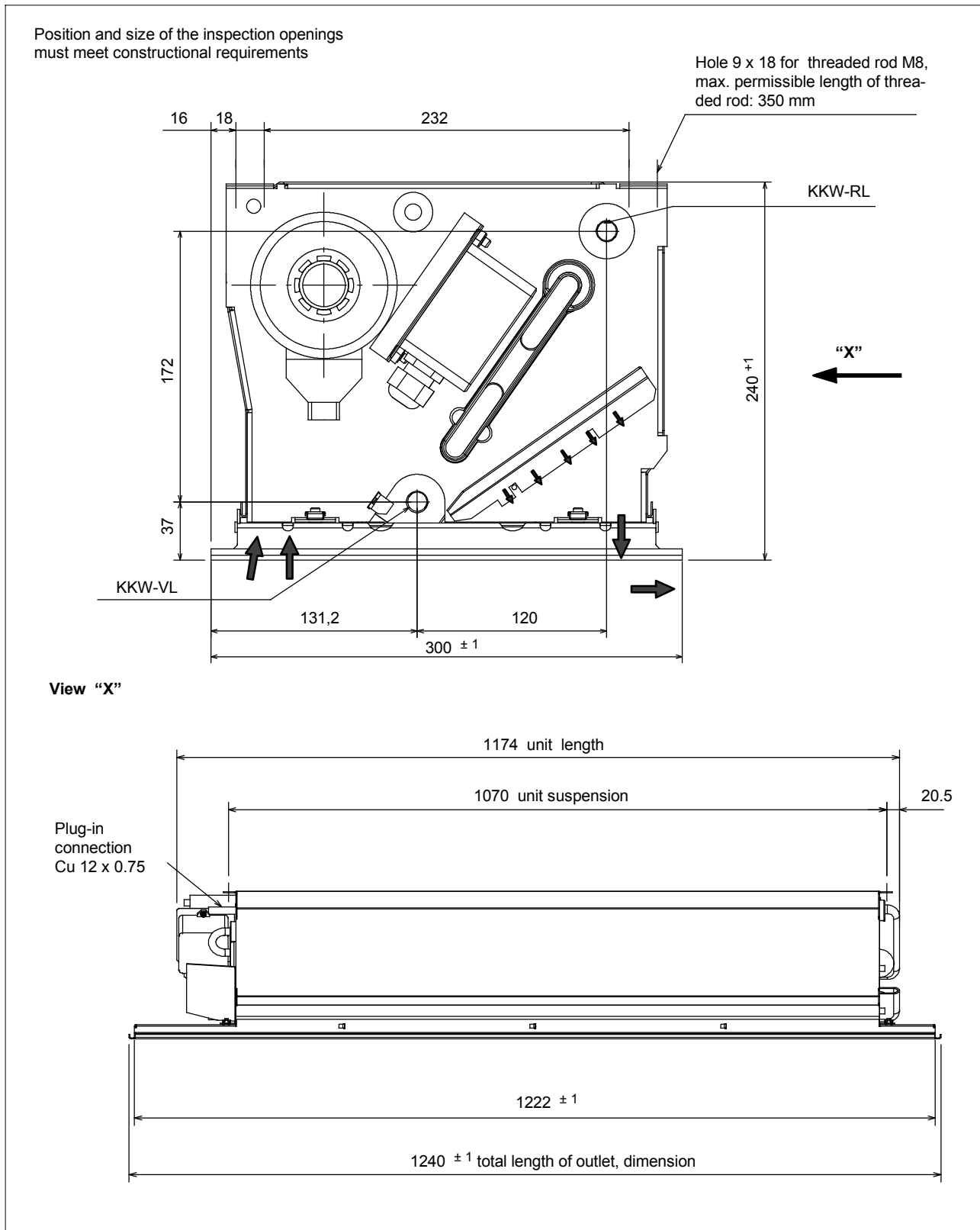

KKW-VL = cooling - water inlet KKW-RL = cooling - water return

Fan coil units for ceiling installation Type VDC

Technical data size 1000 - 2-pipe system - heating or cooling

n [-]	V [m ³ /h]	L _{A18} [dB(A)]	L _{wA} [dB(A)]	Q _k /Δt [W/K]	Q _k ¹⁾ [W]	w _{ok} /Δp _w [kg/h]/[kPa]	P _{el} [W]	I _{max} [mA]
I	200	23	29	35	350	200 / 9.5	22	170
II	290	32	38	48	480		26	
III	350	39	45	56	560		28	
IV	420	44	50	62	620		32	
V	450	49	55	66	660		39	

Data is based on the unit with the inlet/outlet grille installed.

Standard flow rate cooling 200 kg/h

1) Water inlet: 16 °C; air inlet: 26 °C at a height of 1.1 m; non condensing operation.

Legend

- n - speed
- V - flow rate (±10%)
- L_{A18} - sound pressure level, 18 m² Sabine
- L_{wA} - sound power level ±3 dB(A)
(without casing)
- Q_k - cooling capacity
- Δt - temperature difference between t_{vL} - t_R
- w_{ok} - standard flow rate at cooling capacity*
- Δp_w - water-side pressure loss
- t_{vL} - water supply temperature
- t_R - room temperature at height of 1.1 m

*correction for other flow rates see page 32.

Accessories / Special versions

- straight-way valve with electro-thermal actuator

Dimensions

(suitable for plank tiles 300 wide x 1200 or 1250 long)

Flanged installation

Size 1200 - length x width x height
= approx. 1240 x 340 x 240 mm

Recessed installation

Size 1200 - length x width x height
= approx. 1240 x 298 x 240 mm

Fan coil units for ceiling installation Type VDC

Typical arrangement

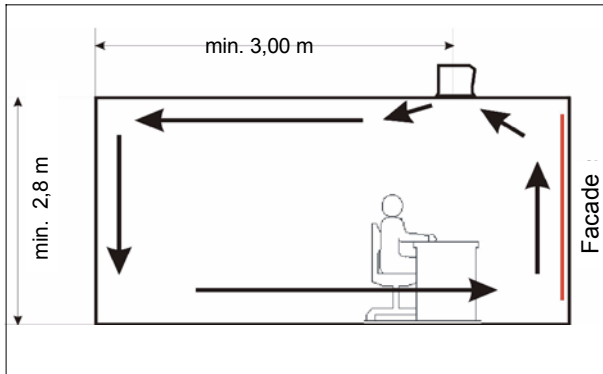

Section through a typical office room, length: 6 m, height: 2.8 m.
 Schematic illustration of indoor air flow.

Cooling mode

Room air heated at façade is drawn directly into the unit where it is cooled. Supply air is diffused along the ceiling, mixes with the ambient air to reduce air speed and temperature difference.

High thermal comfort up to 50 W/m² in speed 1.

Indoor air flow



Speed 1

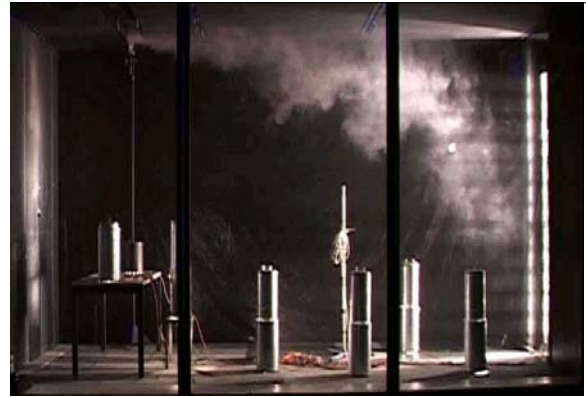

Speed 2

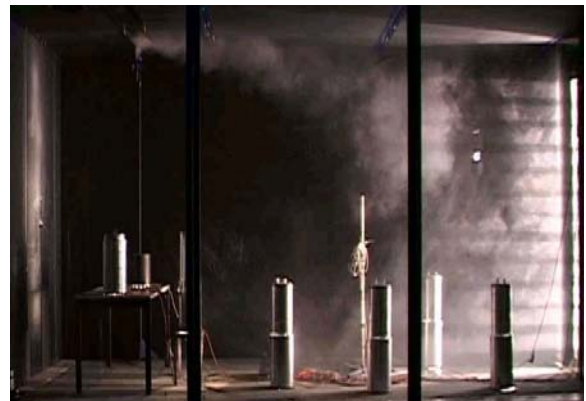

Fan coil units for ceiling installation Type VDC

Cooling capacity for different water flow rates

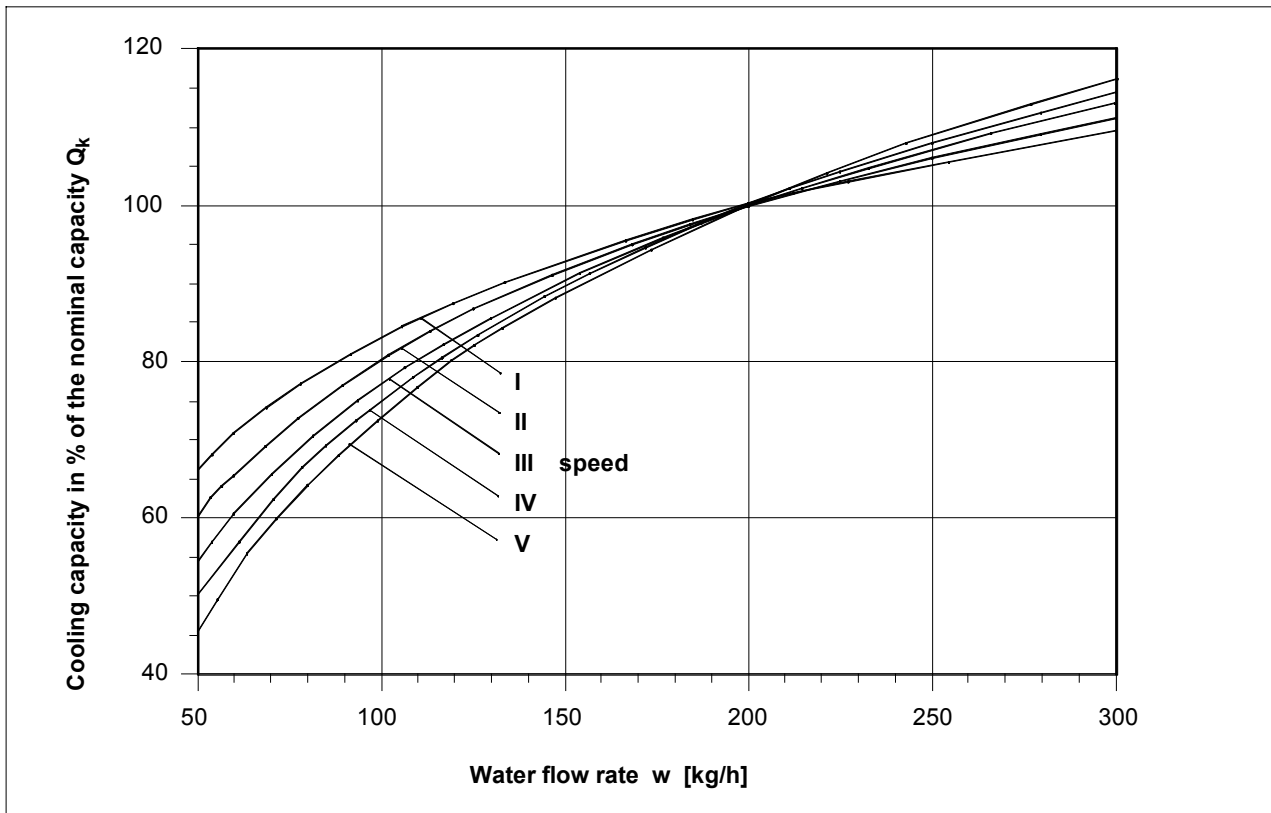

Water-side pressure loss of the cooler for different water flow rates

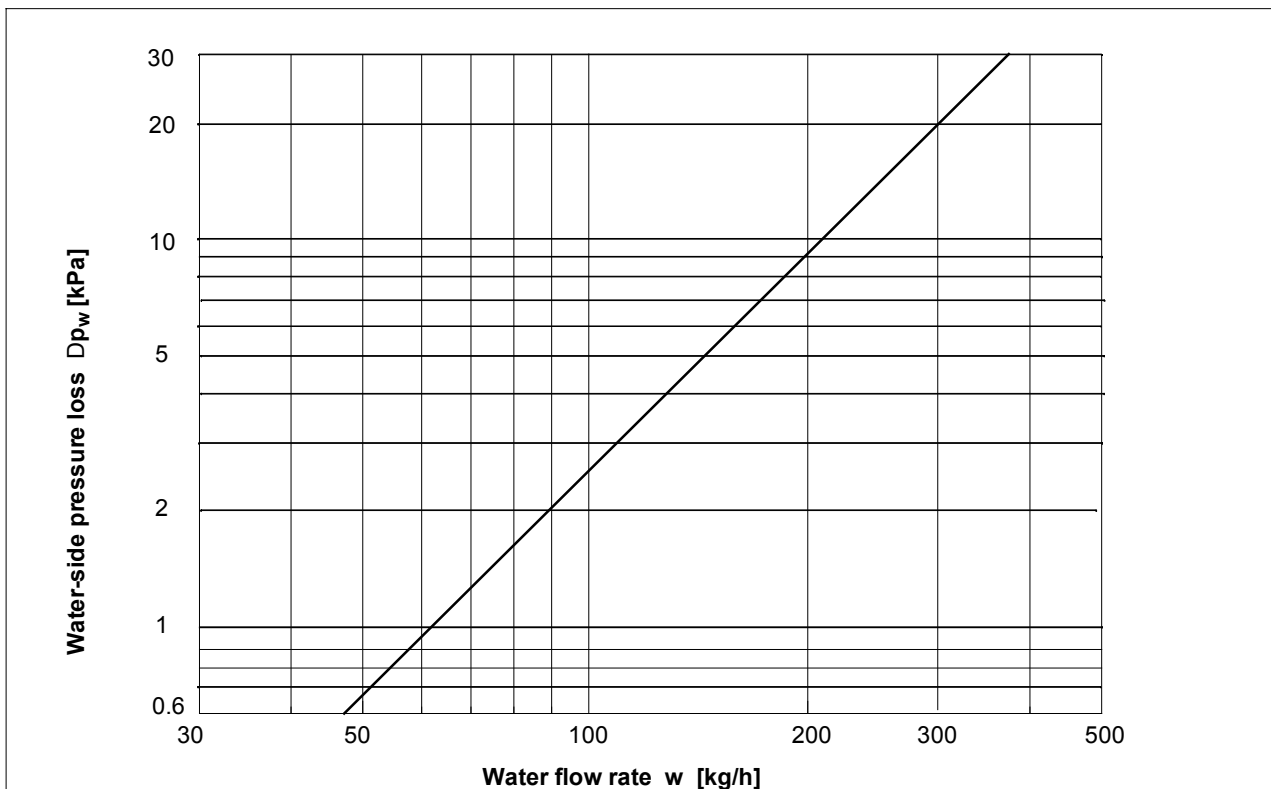

Fan coil units for ceiling installation Type VDC

Nomenclature

VDC - 2 / 1200 / 5 / OF / 1240U / RAL9010 / OV
 (1) (2) (3) (4) (5) (6) (7) (8)

(1)	Series	VDC	= VDC
(2)	Heat exchanger	2	= 2-pipe
(3)	Size	1200	= 1200
(4)	Motor	5 EC	= 5 speeds = EC Motor
(5)	Filter	OF F	= without filter = with filter
(6)	Diffuser	1240U 1220S	= length - flanged installation = length - recessed installation
(7)	Colour diffuser	RAL 9011	= RAL
(8)	Valve set	V2T OV	= 2-way, 2-point, loose = without

Fan coil units for ceiling installation Air Conditioning System Indivent®

Application

Modern air conditioning systems are required to remove heat loads and airborne substances from the occupied space in a safe and effective manner, without producing any draft.

The air conditioning system's construction, however, must leave room for flexibility with view to the appearance and use of the room. Furthermore, the system must be cost effective within a wide performance range.

The LTG air conditioning system Indivent® meets these requirements. It offers high thermal comfort by combining the advantages of both a mixed and a displacement air flow.

Installation, positioning

Units are usually installed over the 'core' wall, in a ceiling bulkhead or in a suspended ceiling. Indivent units require connection to the air conditioning system's primary air supply and the chilled water system.



Installation example for Indivent® system

Advantages

• Comfort

- High cooling capacities and uniform temperatures in the entire occupied space.
- High thermal comfort due to low air speeds and low turbulence.
- High air quality - heat and airborne pollution are exhausted at high level.

• Economy

- The Indivent® system requires only one compact, room saving air duct system since the heat loads are being removed via a compact chilled water system.

• Flexibility

- Interior design of ceiling, lighting and window elements is permitted.
- Workplaces in the room may be arranged according to requirement, without any restrictions.

Mode of operation

The LDB linear diffuser with integrated cooling is installed in the ceiling over the core wall while heating is provided through radiators located under the window. With this configuration, identical flow patterns during summer and winter are achieved.

Recirculated air is drawn in from the room and across a cooling coil. The mixture of fresh air and recirculated air is blown into the room through a linear diffuser. In the local mixed air zone ① the temperature/velocity differences between the ambient air and the supply air are reduced.

Close to the floor, the cooled air jet ② directs itself at low speed and with little turbulence across the occupied space towards the window. The air velocity is virtually independent of the cooling load. The temperature difference between the head and the foot level is less than 1K.

Air heated by room loads rises to high level ③.

Above the occupied space a cushion of warm room air with an increased pollution concentration is formed and removed from the room. In this way the formation of temperature layers ensures cost effective system operation ④.

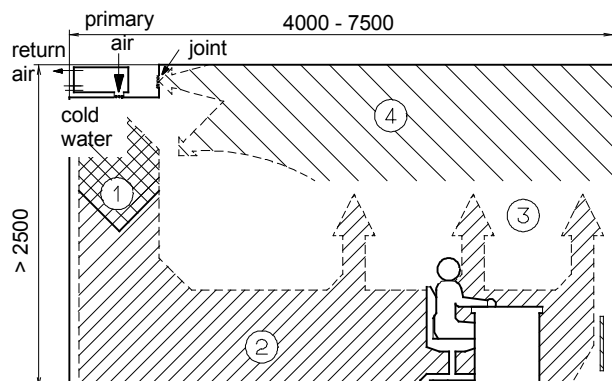

Scheme of Indivent® system flow pattern

① Mixed air flow

Reduction of velocity/temperature differences due to high induction mixing with ambient air

② Displacement air flow

Supply air mixed with ambient air, moves towards the facade

③ Thermal effect and displaced room air transport

air borne pollution and thermal loads to high level.

④ Return flow path to the exhaust location and for mixing with supply air

Range of products

The core element of the Indivent system is the LDB Linear Diffuser with integrated cooling, the Indivent unit. The following types are available:

Type LVC

Fan coil unit for recirculated air operation, water-side valve control, on request with separate fresh air connection. Available in four sizes.

Fan coil units for ceiling installation Air Conditioning System Indivent®

Indoor air flow

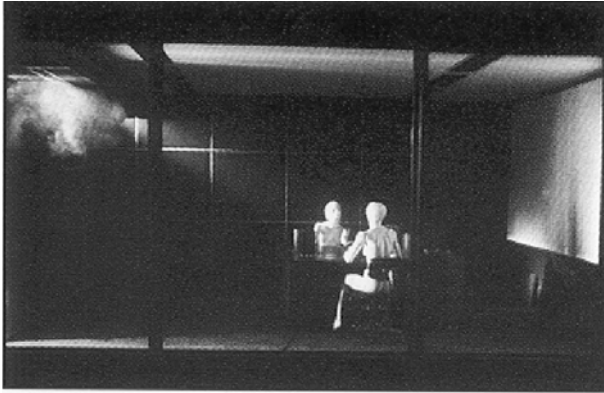

Local mixed air zone

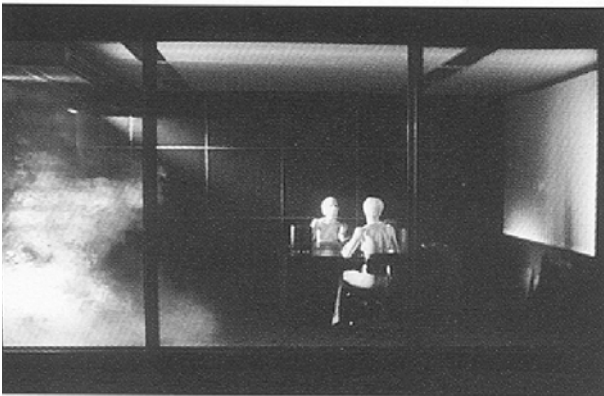

Deflection of the air flow near the floor

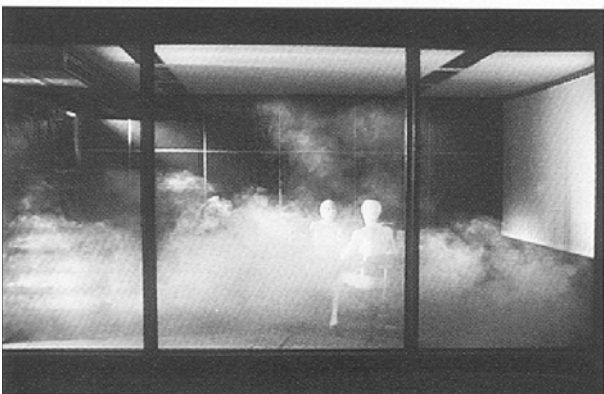

Air heated by occupants or equipment rises to high level

Proposed installation

The **best installation position** for the linear diffusers depends on:

- use of the room
- type of room
- ceiling design
- return air path inside the false ceiling.

Flexibility of diffuser design and adjustment, ensures a perfect solution from both flow technology and aesthetic aspects, for example:

Ideal location for the induction unit/ fan coil unit with return air is within an **open grid ceiling**.

Equally successful are **closed false ceilings or ceiling bulkheads** that are separated through walls extending to the room soffit. Shadow joints in the ceiling boxes or in the marginal gap serve as return air openings. The average speed in these openings should not exceed 0.6 to 0.9 m/s (jet contraction not considered).

For installation of LTG linear diffusers in the area close to the corridor, the following is recommended:

- If there are no ceiling bulkheads separating the supply air from the return air, a distance of about 1 m must be kept between the return air opening and the air diffuser.
- Install the linear diffuser in parallel to the corridor wall. Optimum distance: 0.6 to 1 m.
- When using full height cupboards, a minimum distance of 0.2 m between the air diffuser and the cupboard front must be provided.
- Cabinets directly underneath air diffusers will have no impact on the indoor air flow if a clearance of about 0.4 m to the ceiling is allowed.



Installation example for LTG air conditioning system Indivent®

Fan coil units for ceiling installation Type LVC

View of unit



Application

The fan coil unit type LVC has been designed for two-pipe systems with water-side control by valves.

Mode of operation

LVC units incorporate a built-in tangential fan which draws in air from the ceiling void and cools it within a heat exchanger. The heat exchanger is fitted with an intake filter.

The tangential fans are low-noise and maintenance-free. The speed control is performed through a pole-changing internal rotor motor with five speeds, wired to a factory-mounted terminal box (for terminal connection refer to page 47).

The fan coil units are essentially recirculation type air units but a connection for fresh air is available on request. With that option, the fresh air is supplied through a separate, one-row supply air slot.

Advantages

- **Several sizes**
Four sizes for capacity range
- **Low-noise operation**
due to efficient tangential fan
- **Cost effective**
due to low-energy fan operation
- **Easy control**
Single or group control
- **Flexibility**
On request, the unit is also available with connection for fresh air
- **Adaptability**
due to adjustable outlet for optimising room air flow
- **Design**
The slot profiles are available in a variety of versions and colours.
- **Space saving**
Compact construction suits low ceiling voids.
- **Maintenance-friendly**
due to easy-to-replace filter, maintenance-free motor.

Design

LDB linear diffuser

Cylinders:	polystyrene black, mat polystyrene white, mat
Rails:	aluminium natural anodised painted (similar to RAL) or high-gloss chromium-plated
Air distribution box:	galvanized steel

Integrated cooling

Housing:	galvanized steel
Heat exchanger:	copper pipe with pressed-on aluminum fins
Filter:	Class EU2

Attention: The water inlet temperature must stay above dew-point ($\geq 16^{\circ}\text{C}$) since the unit is not designed for operation with condensate formation.

Fan coil units for ceiling installation Type LVC-2 with linear diffuser LDB 20/8/4 or LDB 12/8/4

Specification

Fan coil unit with one heat exchanger for heating or cooling the ambient air.

Central water-side control.

Vertical or horizontal installation (in the ceiling).

Water connection on the right or left with 1/2" internal thread and venting.

Dimensions

BG	B [mm]	C [mm]	D [mm]	weight [kg] / diffuser length [mm]
500	527	563	685	21 / 1250
630	627	663	885	26 / 1250
800	857	893	1085	31 / 1500
1000	1057	1093	1335	37 / 1750
1250	1257	1293	1535	44 / 2000

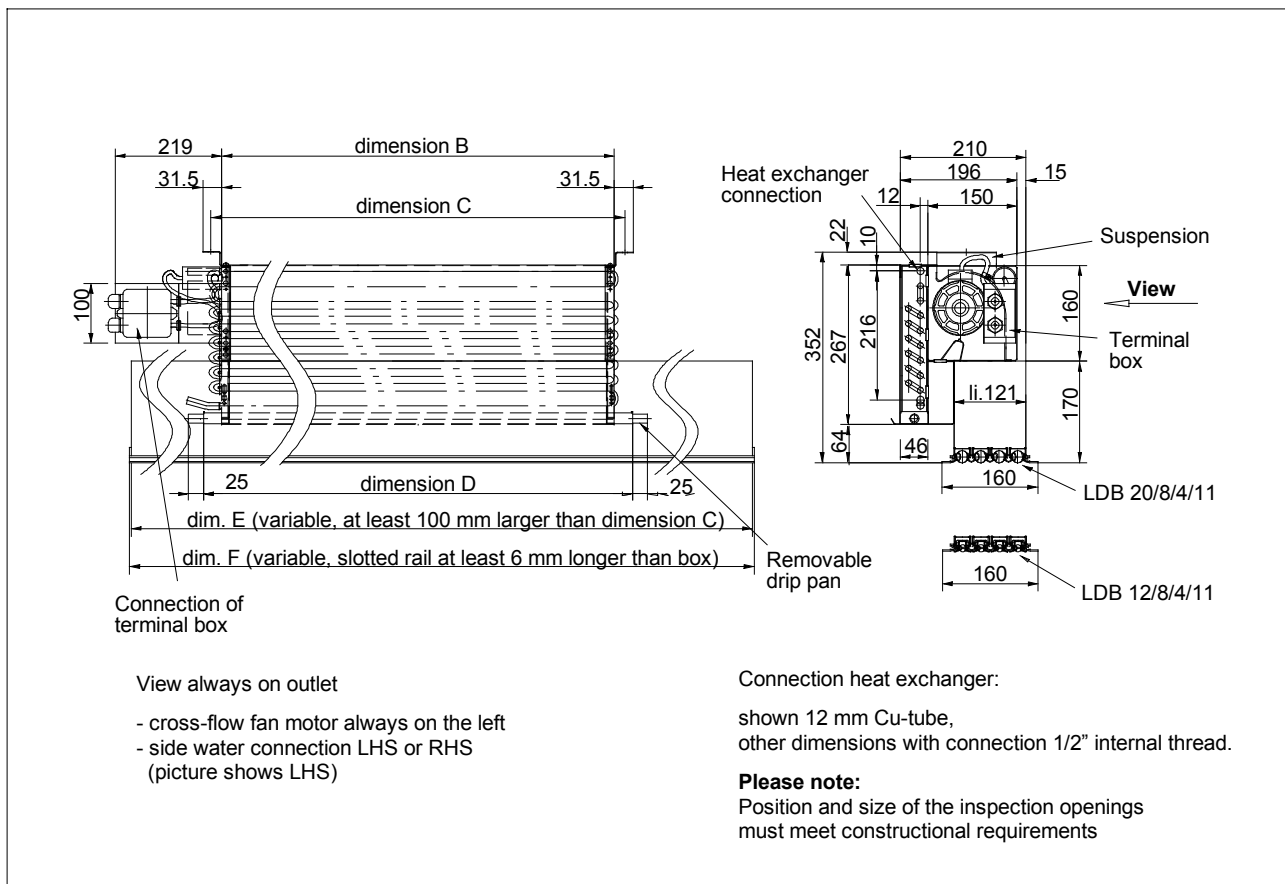

Ceiling fan coil unit type LVC with LDB 20/8/4/11 (LDB 12/8/4/11)

Electrical current and power consumption for units with and without filter

Size	I _{max} [mA]	Electrical power consumption P _{el} (± 20 %) [W]				
		Speed				
		I	II	III	IV	V
630 and 800	90	17 W	18 W	19 W	20 W	22 W
1000 and 1250	130	16 W	18 W	20 W	22 W	24 W

Speed control wiring diagram

Refer to page 47.

Fan coil units for ceiling installation Type LVC-2 with separate fresh air box and LDB 20/8/4 or LDB 12/8/4

Specification

Fan coil unit with one heat exchanger for heating or cooling the ambient air.

Central water-side control.

Vertical or horizontal installation (in the ceiling).

Water connection on the right or left with 1/2" internal thread and venting.

Dimensions

Size	B [mm]	C [mm]	D [mm]	Weight [kg] / diffuser length [mm]
500	527	563	685	21 / 1250
630	627	663	885	26 / 1250
800	857	893	1085	31 / 1500
1000	1057	1093	1335	37 / 1750
1250	1257	1293	1535	44 / 2000

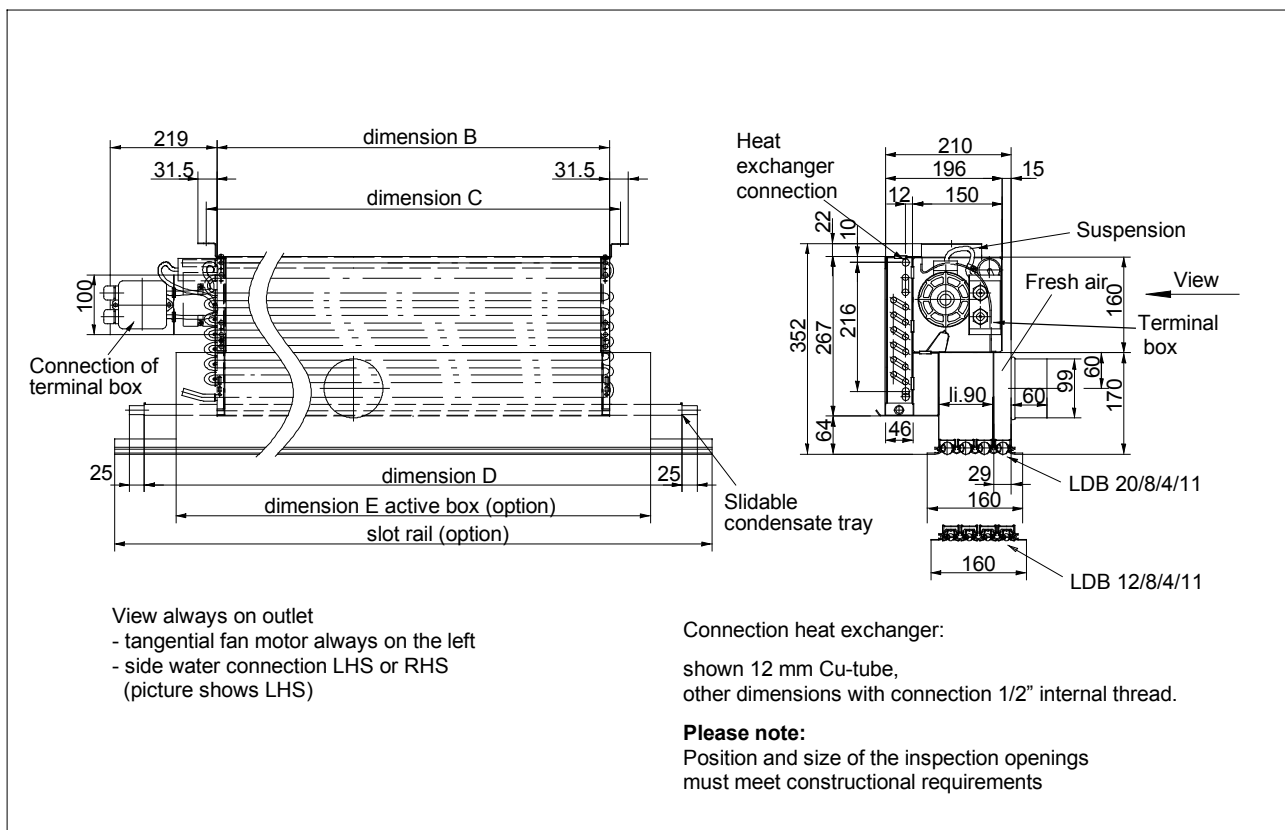

Ceiling fan coil unit type LVC with separate fresh air box with LDB 20/8/4 or LDB 12/8/4

Electrical current and power consumption for units with and without filter

Size	I _{max} [mA]	Electrical power consumption P _{el} (± 20 %) [W]				
		Speed				
		I	II	III	IV	V
630 and 800	90	17 W	18 W	19 W	20 W	22 W
1000 and 1250	130	16 W	18 W	20 W	22 W	24 W

Speed control wiring diagram

Refer to page 47.

Fan coil units for ceiling installation Type LVC-2 with linear diffuser LDB 20/8/3 or LDB 12/8/3

Specification

Fan coil unit with one heat exchanger for heating or cooling the ambient air.

Central water-side control.

Vertical or horizontal installation (in the ceiling).

Water connection on the right or left with 1/2" internal thread and venting.

Dimensions

Size	B [mm]	C [mm]	D [mm]	Weight [kg] / diffuser length [mm]
500	527	563	685	21 / 1250
630	627	663	885	26 / 1250
800	857	893	1085	31 / 1500
1000	1057	1093	1335	37 / 1750
1250	1257	1293	1535	44 / 2000

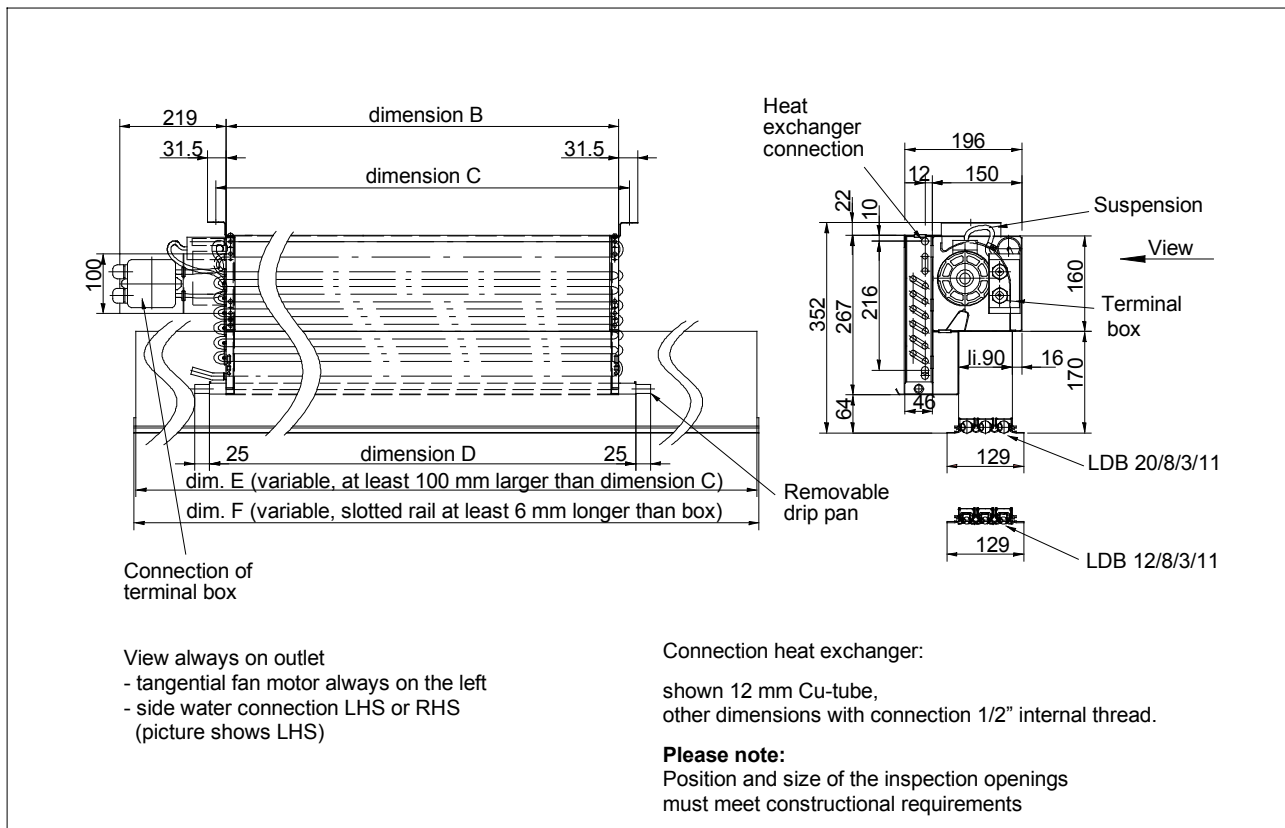

Ceiling fan coil unit type LVC with LDB 20/8/3 or LDB 12/8/3

Electrical current and power consumption for units with and without filter

Size	I _{max} [mA]	Electrical power consumption P _{el} (± 20 %) [W]				
		Speed				
		I	II	III	IV	V
630 and 800	90	17 W	18 W	19 W	20 W	22 W
1000 and 1250	130	16 W	18 W	20 W	22 W	24 W

Speed control wiring diagram

Refer to page 47.

Fan coil units for ceiling installation Type LVC-2 with linear diffuser LDB 20/8/4

Technical data size 630, 2-pipe system

Speed	Box length 1000 mm						Box length 1500 mm					
	without filter			with filter			without filter			with filter		
	V [m ³ /h]	L _{WA} [dB(A)]	Q _{k oF} /Δt [W/K]	V [m ³ /h]	L _{WA} [dB(A)]	Q _{k mF} /Δt [W/K]	V [m ³ /h]	L _{WA} [dB(A)]	Q _{k oF} /Δt [W/K]	V [m ³ /h]	L _{WA} [dB(A)]	Q _{k mF} /Δt [W/K]
I	190	36	48	170	37	43	200	35	45	180	36	42
II	230	43	54	210	42	47	240	39	54	210	41	48
III	270	50	60	240	47	55	280	45	61	250	49	55
IV	310	50	67	280	50	63	320	48	66	290	52	63
V	350	50	70	310	54	68	360	50	69	320	54	66

$$w_{ok} / \Delta p_w = 200 \text{ [kg/h]} / 20 \text{ [kPa]}$$

Technical data size 800, 2-pipe system

Speed	Box length 1000 mm						Box length 1500 mm					
	without filter			with filter			without filter			with filter		
	V [m ³ /h]	L _{WA} [dB(A)]	Q _{k oF} /Δt [W/K]	V [m ³ /h]	L _{WA} [dB(A)]	Q _{k mF} /Δt [W/K]	V [m ³ /h]	L _{WA} [dB(A)]	Q _{k oF} /Δt [W/K]	V [m ³ /h]	L _{WA} [dB(A)]	Q _{k mF} /Δt [W/K]
I	180	34	50	170	37	45	190	34	54	180	35	50
II	220	41	58	200	41	54	240	39	62	210	40	57
III	260	48	66	240	45	63	290	44	70	260	45	66
IV	310	49	73	290	49	71	330	46	78	300	49	75
V	350	50	80	330	51	77	380	49	83	340	51	80

$$w_{ok} / \Delta p_w = 200 \text{ [kg/h]} / 22 \text{ [kPa]}$$

Technical data size 1000, 2-pipe system

EC motor	Box length 1500 mm						Box length 2000 mm					
	without filter			with filter			without filter			with filter		
	V [m ³ /h]	L _{WA} [dB(A)]	Q _{k oF} /Δt [W/K]	V [m ³ /h]	L _{WA} [dB(A)]	Q _{k mF} /Δt [W/K]	V [m ³ /h]	L _{WA} [dB(A)]	Q _{k oF} /Δt [W/K]	V [m ³ /h]	L _{WA} [dB(A)]	Q _{k mF} /Δt [W/K]
	190	26	50	180	29	44	180	26	48	180	29	46
	280	35	70	260	39	64	280	35	70	270	39	65
	370	43	84	330	46	78	390	42	84	360	46	80
	450	48	97	400	51	90	490	47	98	440	51	91
	580	55	112	510	57	108	670	56	113	610	58	106

$$w_{ok} / \Delta p_w = 200 \text{ [kg/h]} / 23 \text{ [kPa]}$$

Technical data size 1250, 2-pipe system

EC motor	Box length 1500 mm						Box length 2000 mm					
	without filter			with filter			without filter			with filter		
	V [m ³ /h]	L _{WA} [dB(A)]	Q _{k oF} /Δt [W/K]	V [m ³ /h]	L _{WA} [dB(A)]	Q _{k mF} /Δt [W/K]	V [m ³ /h]	L _{WA} [dB(A)]	Q _{k oF} /Δt [W/K]	V [m ³ /h]	L _{WA} [dB(A)]	Q _{k mF} /Δt [W/K]
	180	30	55	170	30	47	200	26	54	190	30	47
	280	37	78	250	37	70	310	36	76	270	37	72
	370	45	91	330	45	85	410	43	92	360	46	86
	450	50	112	410	50	98	490	48	106	440	51	101
	590	54	120	530	58	118	630	54	122	570	58	116

$$w_{ok} / \Delta p_w = 200 \text{ [kg/h]} / 25 \text{ [kPa]}$$

V - flow rate (approx. values, tolerance ±10%)
L_{WA} - sound power level ±3 dB(A) (without casing)
Δt - temperature difference between suction air temperature before entering the heat exchanger and water supply

Q_{k oF} - cooling capacity (without filter)
Q_{k mF} - cooling capacity (with filter)
w_{ok} - standard flow rate at cooling capacity
Δp_w - water-side pressure loss

Fan coil units for ceiling installation Type LVC-2 with linear diffuser LDB12/8/4

Technical data size 630, 2-pipe system

Speed	Box length 1000 mm						Box length 1500 mm					
	without filter			with filter			without filter			with filter		
	V [m ³ /h]	L _{WA} [dB(A)]	Q _{k oF} /Δt [W/K]	V [m ³ /h]	L _{WA} [dB(A)]	Q _{k mF} /Δt [W/K]	V [m ³ /h]	L _{WA} [dB(A)]	Q _{k oF} /Δt [W/K]	V [m ³ /h]	L _{WA} [dB(A)]	Q _{k mF} /Δt [W/K]
I	180	39	45	160	39	40	190	39	47	180	38	42
II	220	45	52	190	44	46	220	42	53	210	43	47
III	250	50	56	220	47	50	370	47	59	250	48	53
IV	290	52	61	260	52	58	310	51	64	280	50	61
V	320	53	70	290	54	63	340	52	70	310	58	63

$$w_{ok} / \Delta p_w = 200 \text{ [kg/h]} / 20 \text{ [kPa]}$$

Technical data size 800, 2-pipe system

Speed	Box length 1000 mm						Box length 1500 mm					
	without filter			with filter			without filter			with filter		
	V [m ³ /h]	L _{WA} [dB(A)]	Q _{k oF} /Δt [W/K]	V [m ³ /h]	L _{WA} [dB(A)]	Q _{k mF} /Δt [W/K]	V [m ³ /h]	L _{WA} [dB(A)]	Q _{k oF} /Δt [W/K]	V [m ³ /h]	L _{WA} [dB(A)]	Q _{k mF} /Δt [W/K]
I	170	36	48	150	36	44	200	37	49	160	36	43
II	200	42	57	180	41	51	240	42	57	200	41	52
III	250	48	63	220	45	59	290	48	65	240	46	60
IV	290	49	69	260	49	65	340	51	73	290	49	67
V	330	52	76	290	52	71	390	52	79	330	51	73

$$w_{ok} / \Delta p_w = 200 \text{ [kg/h]} / 22 \text{ [kPa]}$$

Technical data size 1000, 2-pipe system

EC motor	Box length 1500 mm						Box length 2000 mm					
	without filter			with filter			without filter			with filter		
	V [m ³ /h]	L _{WA} [dB(A)]	Q _{k oF} /Δt [W/K]	V [m ³ /h]	L _{WA} [dB(A)]	Q _{k mF} /Δt [W/K]	V [m ³ /h]	L _{WA} [dB(A)]	Q _{k oF} /Δt [W/K]	V [m ³ /h]	L _{WA} [dB(A)]	Q _{k mF} /Δt [W/K]
	170	27	48	160	30	43	240	26	60	170	29	44
	250	40	67	230	39	64	300	38	72	260	39	64
	320	46	79	290	46	75	440	46	83	330	47	77
	390	51	91	360	52	86	480	50	96	430	52	90
	490	57	105	450	58	100	590	56	107	560	58	103

$$w_{ok} / \Delta p_w = 200 \text{ [kg/h]} / 23 \text{ [kPa]}$$

Technical data size 1250, 2-pipe system

EC motor	Box length 1500 mm						Box length 2000 mm					
	without filter			with filter			without filter			with filter		
	V [m ³ /h]	L _{WA} [dB(A)]	Q _{k oF} /Δt [W/K]	V [m ³ /h]	L _{WA} [dB(A)]	Q _{k mF} /Δt [W/K]	V [m ³ /h]	L _{WA} [dB(A)]	Q _{k oF} /Δt [W/K]	V [m ³ /h]	L _{WA} [dB(A)]	Q _{k mF} /Δt [W/K]
	150	27	54	150	28	48	180	26	57	170	29	48
	200	39	74	230	39	67	230	38	77	250	39	70
	290	47	89	300	46	81	270	45	92	330	45	83
	370	51	100	340	50	94	320	51	103	370	50	96
	480	57	116	440	57	107	360	58	118	480	58	113

$$w_{ok} / \Delta p_w = 200 \text{ [kg/h]} / 25 \text{ [kPa]}$$

V - flow rate (approx. values, tolerance ±10%)
L_{WA} - sound power level ±3 dB(A) (without casing)
Δt - temperature difference between suction air temp. before entering the heat exchanger and water supply

Q_{k oF} - cooling capacity (without filter)
Q_{k mF} - cooling capacity (with filter)
w_{ok} - standard flow rate at cooling capacity
Δp_w - water-side pressure loss

Fan coil units for ceiling installation Type LVC-2 with separate fresh air box and LDB 20/8/4 or LDB 20/8/3

Technical data size 630, 2-pipe system

Speed	Box length 1000 mm						Box length 1500 mm					
	without filter			with filter			without filter			with filter		
	V [m ³ /h]	L _{WA} [dB(A)]	Q _{k oF/Δt} [W/K]	V [m ³ /h]	L _{WA} [dB(A)]	Q _{k mF/Δt} [W/K]	V [m ³ /h]	L _{WA} [dB(A)]	Q _{k oF/Δt} [W/K]	V [m ³ /h]	L _{WA} [dB(A)]	Q _{k mF/Δt} [W/K]
I	180	40	46	180	40	43	190	37	47	180	38	45
II	210	45	52	190	43	48	220	43	53	210	42	50
III	260	51	58	230	48	55	260	47	61	240	48	57
IV	300	51	64	260	51	61	310	51	65	280	52	62
V	340	57	68	290	55	65	350	55	70	290	56	68

$$w_{ok} / \Delta p_w = 200 \text{ [kg/h]} / 20 \text{ [kPa]}$$

Technical data size 800, 2-pipe system

Speed	Box length 1000 mm						Box length 1500 mm					
	without filter			with filter			without filter			with filter		
	V [m ³ /h]	L _{WA} [dB(A)]	Q _{k oF/Δt} [W/K]	V [m ³ /h]	L _{WA} [dB(A)]	Q _{k mF/Δt} [W/K]	V [m ³ /h]	L _{WA} [dB(A)]	Q _{k oF/Δt} [W/K]	V [m ³ /h]	L _{WA} [dB(A)]	Q _{k mF/Δt} [W/K]
I	190	34	49	170	35	46	200	38	52	160	36	47
II	210	40	57	200	40	52	240	44	59	200	41	54
III	250	47	64	240	45	61	280	47	71	240	46	62
IV	290	51	71	280	48	68	330	51	75	280	49	70
V	330	54	77	310	51	74	360	53	81	310	52	74

$$w_{ok} / \Delta p_w = 200 \text{ [kg/h]} / 22 \text{ [kPa]}$$

Technical data size 1000, 2-pipe system

EC motor	Box length 1500 mm						Box length 2000 mm					
	without filter			with filter			without filter			with filter		
	V [m ³ /h]	L _{WA} [dB(A)]	Q _{k oF/Δt} [W/K]	V [m ³ /h]	L _{WA} [dB(A)]	Q _{k mF/Δt} [W/K]	V [m ³ /h]	L _{WA} [dB(A)]	Q _{k oF/Δt} [W/K]	V [m ³ /h]	L _{WA} [dB(A)]	Q _{k mF/Δt} [W/K]
	160	27	49	140	30	44	210	26	51	170	29	44
	250	41	68	230	39	60	300	37	69	250	39	63
	330	47	81	300	46	76	390	44	84	330	45	77
	410	52	92	360	52	86	450	51	93	390	51	87
	520	57	103	450	57	100	630	56	110	510	57	101

$$w_{ok} / \Delta p_w = 200 \text{ [kg/h]} / 23 \text{ [kPa]}$$

Technical data size 1250, 2-pipe system

EC motor	Box length 1500 mm						Box length 2000 mm					
	without filter			with filter			without filter			with filter		
	V [m ³ /h]	L _{WA} [dB(A)]	Q _{k oF/Δt} [W/K]	V [m ³ /h]	L _{WA} [dB(A)]	Q _{k mF/Δt} [W/K]	V [m ³ /h]	L _{WA} [dB(A)]	Q _{k oF/Δt} [W/K]	V [m ³ /h]	L _{WA} [dB(A)]	Q _{k mF/Δt} [W/K]
	160	27	53	140	27	47	180	25	54	160	27	47
	250	36	74	230	37	66	280	36	74	250	35	67
	320	47	88	300	45	82	360	45	89	330	43	83
	400	51	99	360	49	93	440	51	102	390	50	95
	520	58	112	470	56	109	560	56	116	510	56	109

$$w_{ok} / \Delta p_w = 200 \text{ [kg/h]} / 25 \text{ [kPa]}$$

- V** - flow rate (approx. values, tolerance ±10%)
L_{WA} - sound power level ±3 dB(A) (without casing)
Δt - temp. diff. between suction air temp. before entering the heat exchanger and water supply
V_P - fresh air flow rate
Q_{k oF} - cooling capacity (without filter)
Q_{k mF} - cooling capacity (with filter)
w_{ok} - standard flow rate at cooling capacity

- Δp_w** - water-side pressure loss
L_{WA P} - sound power level fresh air

Acoustic power level for separate fresh air box

V _{prim} [m ³ /(hm)]	80	90	100
L _{WA P} [dB(A)]	25	28	31

The total acoustic power level may be calcul. as follows:
 $L_{WA} = 10 * \log(10^{0.1 * L_{WA P}} + 10^{0.1 * L_{WA, LVC}})$

Fan coil units for ceiling installation Type LVC-2 with separate fresh air box and LDB 12/8/4 or LDB 12/8/3

Technical data size 630, 2-pipe system

Speed	Box length 1000 mm						Box length 1500 mm					
	without filter			with filter			without filter			with filter		
	V [m ³ /h]	L _{WA} [dB(A)]	Q _{k oF/Δt} [W/K]	V [m ³ /h]	L _{WA} [dB(A)]	Q _{k mF/Δt} [W/K]	V [m ³ /h]	L _{WA} [dB(A)]	Q _{k oF/Δt} [W/K]	V [m ³ /h]	L _{WA} [dB(A)]	Q _{k mF/Δt} [W/K]
I	170	39	43	160	40	39	180	40	44	170	37	42
II	190	45	49	180	45	45	210	45	51	200	43	49
III	220	51	54	210	48	51	240	49	58	220	48	54
IV	250	53	58	230	52	58	270	52	66	250	51	60
V	270	57	60	250	55	61	300	56	69	270	55	63

$$w_{ok} / \Delta p_w = 200 \text{ [kg/h]} / 20 \text{ [kPa]}$$

Technical data size 800, 2-pipe system

Speed	Box length 1000 mm						Box length 1500 mm					
	without filter			with filter			without filter			with filter		
	V [m ³ /h]	L _{WA} [dB(A)]	Q _{k oF/Δt} [W/K]	V [m ³ /h]	L _{WA} [dB(A)]	Q _{k mF/Δt} [W/K]	V [m ³ /h]	L _{WA} [dB(A)]	Q _{k oF/Δt} [W/K]	V [m ³ /h]	L _{WA} [dB(A)]	Q _{k mF/Δt} [W/K]
I	160	36	44	140	36	39	180	36	49	160	35	44
II	190	41	52	170	40	47	200	41	53	190	40	53
III	220	46	60	200	45	54	250	49	64	220	45	61
IV	250	48	65	230	48	62	290	51	72	270	49	67
V	280	51	74	260	50	67	320	53	78	300	51	73

$$w_{ok} / \Delta p_w = 200 \text{ [kg/h]} / 22 \text{ [kPa]}$$

Technical data size 1000, 2-pipe system

EC motor	Box length 1500 mm						Box length 2000 mm					
	without filter			with filter			without filter			with filter		
	V [m ³ /h]	L _{WA} [dB(A)]	Q _{k oF/Δt} [W/K]	V [m ³ /h]	L _{WA} [dB(A)]	Q _{k mF/Δt} [W/K]	V [m ³ /h]	L _{WA} [dB(A)]	Q _{k oF/Δt} [W/K]	V [m ³ /h]	L _{WA} [dB(A)]	Q _{k mF/Δt} [W/K]
	150	28	44	140	29	40	180	28	47	160	30	42
	210	40	62	200	39	57	250	41	65	260	39	60
	270	47	75	250	45	68	320	48	77	300	46	73
	330	52	82	300	50	78	400	52	88	360	51	83
	410	57	95	370	56	94	510	58	101	460	57	95

$$w_{ok} / \Delta p_w = 200 \text{ [kg/h]} / 23 \text{ [kPa]}$$

Technical data size 1250, 2-pipe system

EC motor	Box length 1500 mm						Box length 2000 mm					
	without filter			with filter			without filter			with filter		
	V [m ³ /h]	L _{WA} [dB(A)]	Q _{k oF/Δt} [W/K]	V [m ³ /h]	L _{WA} [dB(A)]	Q _{k mF/Δt} [W/K]	V [m ³ /h]	L _{WA} [dB(A)]	Q _{k oF/Δt} [W/K]	V [m ³ /h]	L _{WA} [dB(A)]	Q _{k mF/Δt} [W/K]
	130	28	49	120	23	42	150	25	49	140	27	45
	210	40	67	180	34	61	240	36	69	200	36	65
	270	44	80	240	43	75	310	45	85	270	48	77
	330	50	90	300	49	87	370	51	96	330	51	91
	410	57	104	380	56	101	490	56	111	420	58	101

$$w_{ok} / \Delta p_w = 200 \text{ [kg/h]} / 25 \text{ [kPa]}$$

Legend

- V** - flow rate (approx. values, tolerance ±10%)
L_{WA} - sound power level ±3 dB(A) (without casing)
Δt - temp. diff. between suction air temperature before entering the heat exchanger and water supply
V_P - fresh air flow rate
q_{k oF} - cooling capacity (without filter)
Q_{k mF} - cooling capacity (with filter)
w_{ok} - standard flow rate at cooling capacity

- Δp_w** - water-side pressure loss
L_{WA P} - sound power level fresh air

Acoustic power level for separate fresh air box

- V_P** [m³/(h·m)] 80 90 100
L_{WA P} [dB(A)] 25 28 31

The total acoustic power level may be calcul. as follows:
 $L_{WA} = 10 * \log (10^{0.1 * L_{WA P}} + 10^{0.1 * L_{WA, LVC}})$

Fan coil units for ceiling installation Type LVC-2, 2-pipe-system – cooling or heating

Selection Example

Given values:

Required cooling capacity:	$Q_{k\text{ soll}} = 840\text{ W}$
Water inlet temperature:	$t_{VL} = 16\text{ °C}$
Room temperature/ Suction air temperature before entering the heat exchanger:	$t_R/t_A = 26\text{ °C}$
Fresh air flow rate:	$V_P = 150\text{ m}^3/\text{h}$
Fresh air temperature:	$t_P = 18\text{ °C}$
Installation dimensions / slot length:	$L_S = 1500\text{ mm}$
Cooling capacity fresh air:	$Q_P = 400\text{ W (with } \Delta t_P = t_R - t_P = 8\text{ K)}$
Secondary cooling capacity (heat exchanger):	$Q_k = Q_{k\text{ soll}} - Q_P = 440\text{ W}$

With $\Delta t = t_A - t_{VL} = 10\text{ K}$
specific secondary cooling capacity $Q_k/\Delta t = 44\text{ W/K}$

With a given box length of 1500 mm and $Q_k/\Delta t = 47\text{ W/K}$, the following unit may be selected:

→ **LVC, size 800 with LDB 20/8/4 with separate fresh air box at speed I**

The following total cooling capacity is obtained:

**Total cooling capacity at
standard water flow rate:** $(Q_{k\text{ mF}} + Q_P): Q_{k\text{ ges}} 470\text{ W} + 400\text{ W} = 870\text{ W}$

The total cooling capacity is larger than the required cooling capacity. Since the fresh air cooling capacity depends on the fresh air flow rate, and the latter is fixed by the required air change rate, the secondary cooling capacity may be reduced by changing the nominal water volume.

**Required secondary
cooling capacity:** $(Q_{k\text{ soll}} - Q_P) Q_{k\text{ erf}} 840\text{ W} - 400\text{ W} = 440\text{ W}$

**Share of the secondary cooling capacity in % when
using the nominal water volume:** $440\text{ W} / 470\text{ W} = 0.93 \rightarrow 93\%$

According to the diagrams on page 39 the following is obtained:

Water flow rate
at a 94% secondary cooling capacity: **160 kg/h**

Pressure loss at 160 kg/h: **abt. 16 kPa** (reading)

The secondary cooling capacity may be influenced by the choice of the size, the slot length and by the modification of the water flow rate.

Calculation of the total acoustic power level

The total acoustic power level is calculated by adding up the individual acoustic power levels:

Acoustic power level of the unit: $L_{wA,LVC} = 36\text{ dB(A)}$ (from the selection chart)

Acoustic power of fresh air: $L_{wA P} = 31\text{ dB(A)}$ ($V_P = 100\text{ m}^3/\text{hm}$)

Total acoustic power level: $L_{wA} = 10 * \log (10^{0.1*31} + 10^{0.1*35}) = 37.4\text{ dB(A)}$

Fan coil units for ceiling installation Type LVC-2, 2-pipe-system – cooling or heating

Capacity with different water flow rates

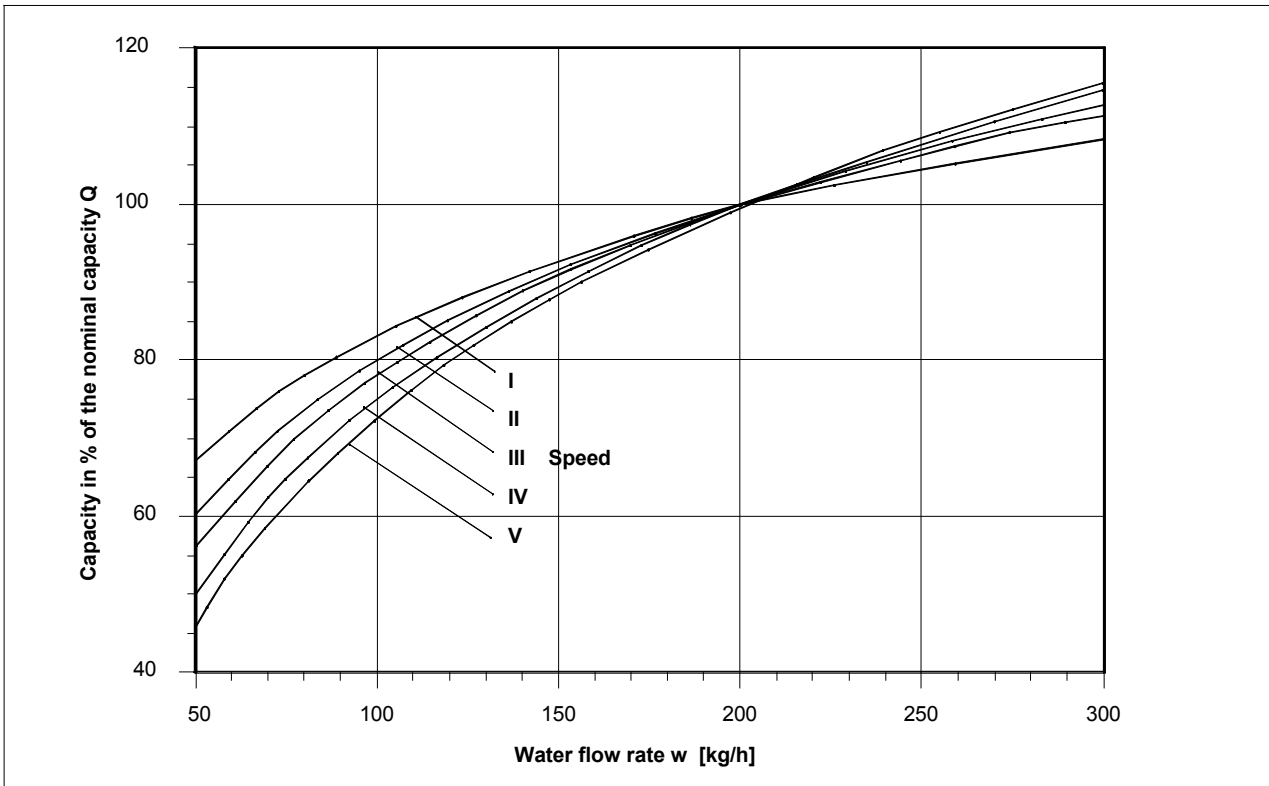

Water-side pressure loss for different water flow rates

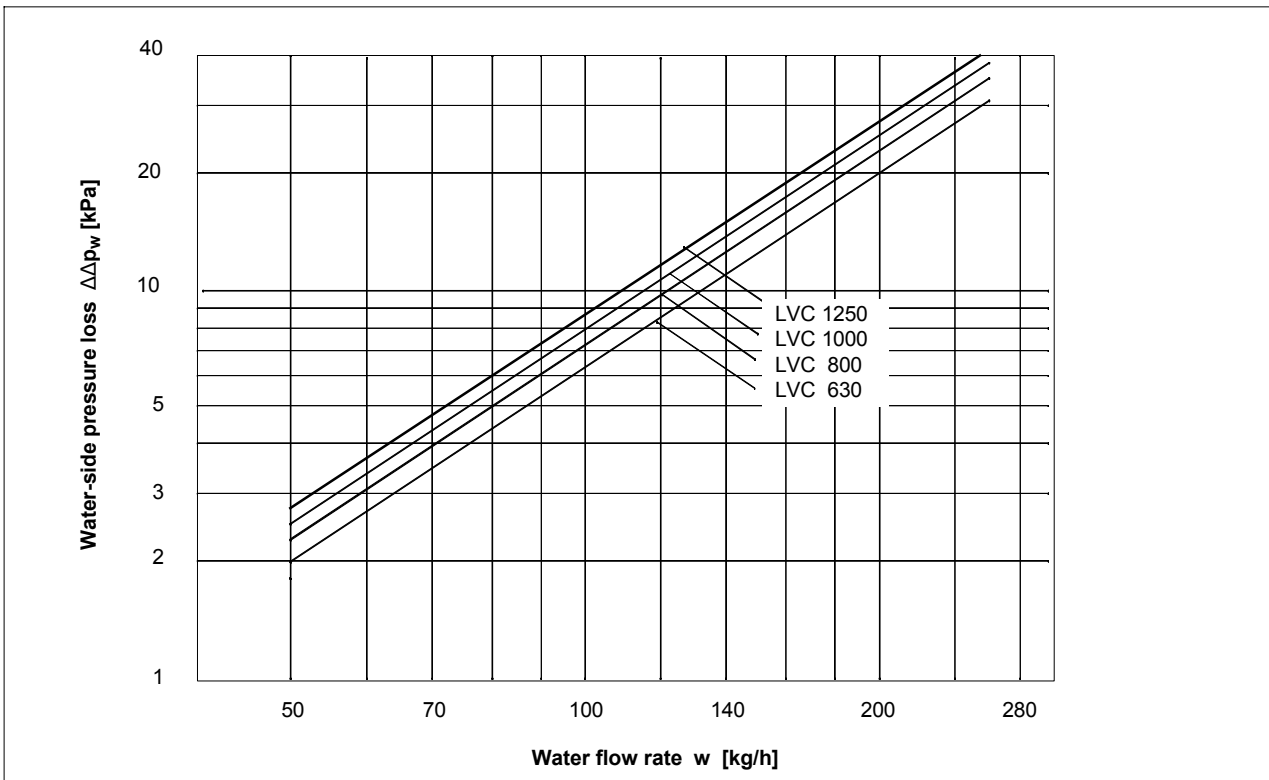

Fan coil units for ceiling installation Type LVC

Nomenclature fan coil unit

LVC - 2 / 800 / 5 / R / O / 20 / 3 / 1500
(1) (2) (3) (4) (5) (6) (7) (8) (9)

(1) Series	LVC	= LVC
(2) Heat exchanger	2 4	= 2-pipe = 4-pipe
(3) Size	630 800 1000 1250	= 630 = 800 = 1000 = 1250
(4) Motor	5 EC	= 5-speeds (only size 630, 800) = EC Motor
(5) Water connection	R L	= on the right = on the left
(6) Fresh air	O M	= without = with
(7) Diffuser type	20 12	= LDB 20 = LDB 12
(8) No. of slots	3 4	= 3 = 4
(9) Diffuser length	1500	= 1500

Nomenclature air diffuser

LDB 20/8 3 / 00 / - - / E6-EV 1 / ... / 2000 / S / 1
(1) (2) (3) (4) (5) (6) (7) (8) (9)

(1) Type	LDB 12/8 LDB 20/8	= LDB 12/8 = LDB 20/8
(2) No. of slots	3 4	= 3 = 4
(3) Border profile left - right	0...8	= type ...
(4) Additional profile left - right	–	= without
(4) Additional profile left - right	–	= without
(5) Surface	0...8 E2 E6 LG LM C R X	= type ... = anodized, brushed = anodized, unbrushed = painted, glossy = painted, matt = chromium-plated = unfinished = special finish
(6) Colour	RAL colour Anodizing shade	= painted = anodized
(7) Slot length (0...2000 mm)	2000	= 2000 mm
(8) Nozzle colour	S W G C	= black = white grey aluminium chromium-plated
(9) End caps	– 1 2 3	= without = both sides = on the left = on the right

Fan coil units for ceiling installation

Speed Control Wiring Diagram Type VKH and LVC

Speed control wiring diagram

- Note:**
- Capacitor motor with 5 tapings
 - Multiple unit triggering possible
 - The technical data contain details about the current consumption and the corresponding electrical power

Note :
For a smooth and safe start of the fan coil units, it is necessary to use speed III.

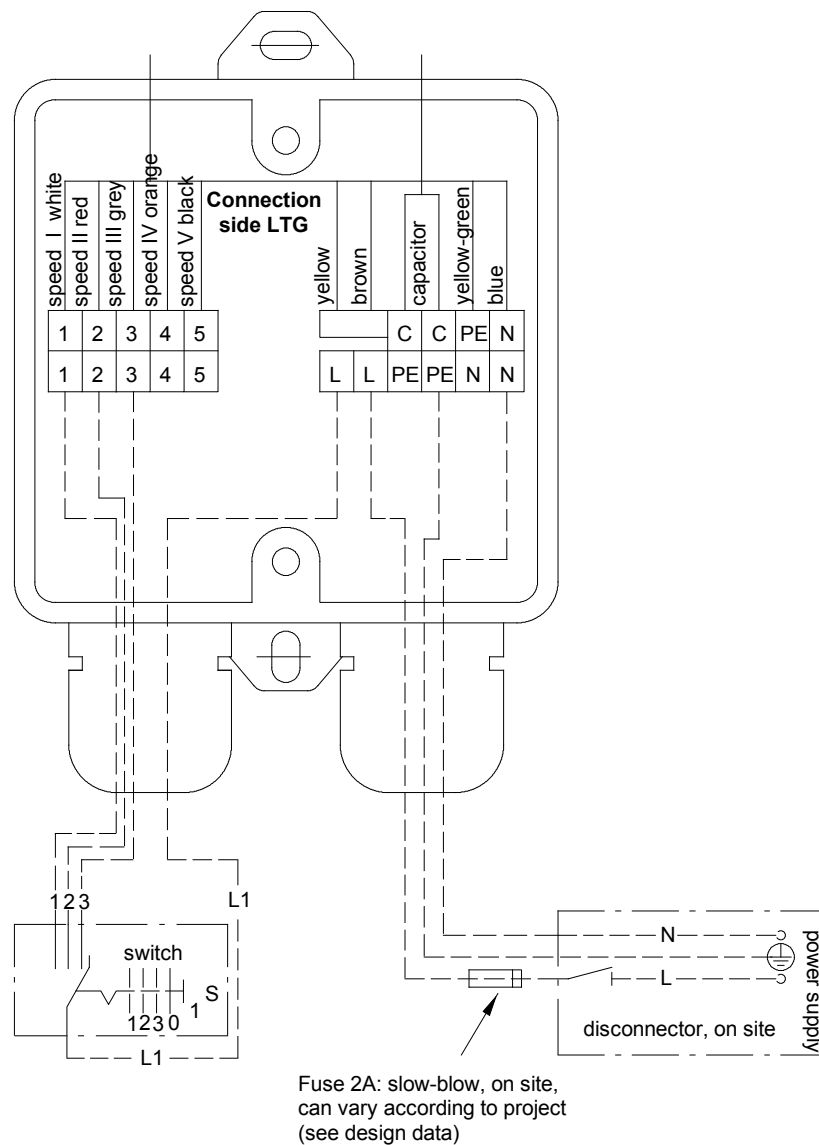

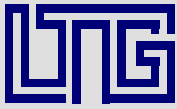

**AIR TECH
SYSTEMS**

Comfort Air Technology

Air-Water Systems
Air Diffusers
Air Distribution

Process Air Technology

Fans
Filtration technology
Humidification Technology

Engineering Services

Laboratory Test / Experiment
Field Measurement / Optimisation
Simulation / Analysis
R&D / Start-up

LTG Aktiengesellschaft

Grenzstraße 7
70435 Stuttgart
Germany
Tel.: +49 711 8201-0
Fax: +49 711 8201-720
info@LTG.de
www.LTG.net

LTG Incorporated

105 Corporate Drive, Suite E
Spartanburg, SC 29303
USA
Tel.: +1 864 599-6340
Fax: +1 864 599-6344
info@LTG-INC.net
www.LTG-INC.net