

Technical Brochure

LTG Air Distribution

Pressure controllers DRE

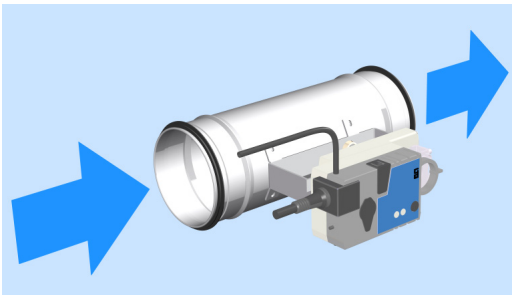

Round

Technical brochure Pressure controllers DRE

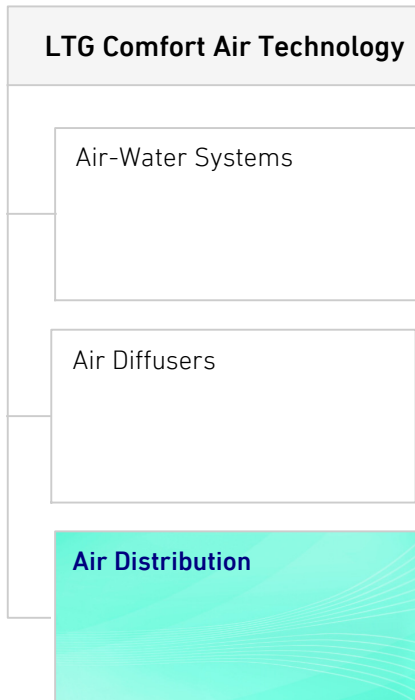

Content	Page
Unit view, application, installation, typical installation in the duct network	3
Function, materials, finishes, accessories, special versions, application ranges, limits	4
Selection table, correction values	5
Dimensions, weight	6
Airborne sound transmission without silencer	7
Airborne sound transmission with silencer	8
Casing sound emission without insulating case	9
Casing sound emission insulating case	10
Examples of calculation	11
Nomenclature, ordering code	12

Notes

Dimensions stated in this brochure are in mm.

Dimensions stated in this brochure are subject to General Tolerances, according to DIN ISO 2768-vL.

The actual specifications are available as a word document at your local distributor or at www.LTG.net.

LTG planning tools – we support you!

Ask for your own DVD with helpful tools, such as dimensioning programs, streaming videos and product information! Also available: our product overviews about air diffusers, air-water systems and air distribution products.

Visit us on www.LTG.net and get detailed technical information as PDF files at „support/download“.



Technical brochure

Pressure controllers DRE

Unit view

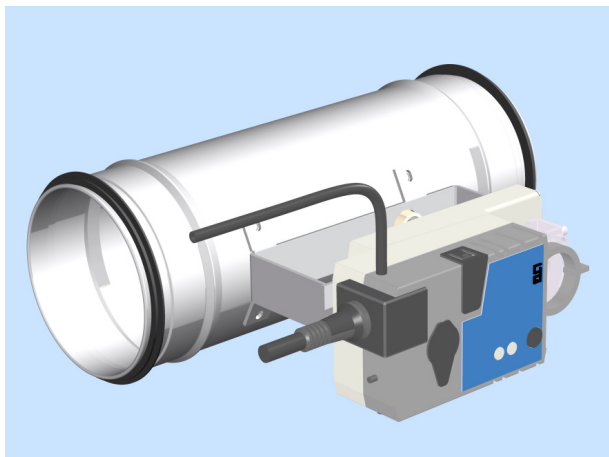

Application

The DRE pressure controllers are used for line pressure regulation in air pipes. They ensure that a comparable inlet pressure applies at all connected air passages.

When the fan pressure is high enough, all lines automatically adjust to one another. Based on the reported measured value, the speed of the supply air fan can be reduced until the first flow rate controller is, for example, 80 % open (control at point of lowest pressure). The installation location for the control valve is independent of the position of the pressure tapping point.

Line pressures of 2...300 Pa are controlled.

Installation

The flow rate controller itself does not place any particular requirements on an inflow section. For positioning the measurement point inside the duct, it is however important that it is attached not directly, but with the largest possible clearance after a fault (preferably attached before the fault).

The pressure tapping point must be provided by others and connected to the controller by means of a pressure measuring tube. Appropriate correction of the height and tube length must be performed.

Typical installation in the duct network

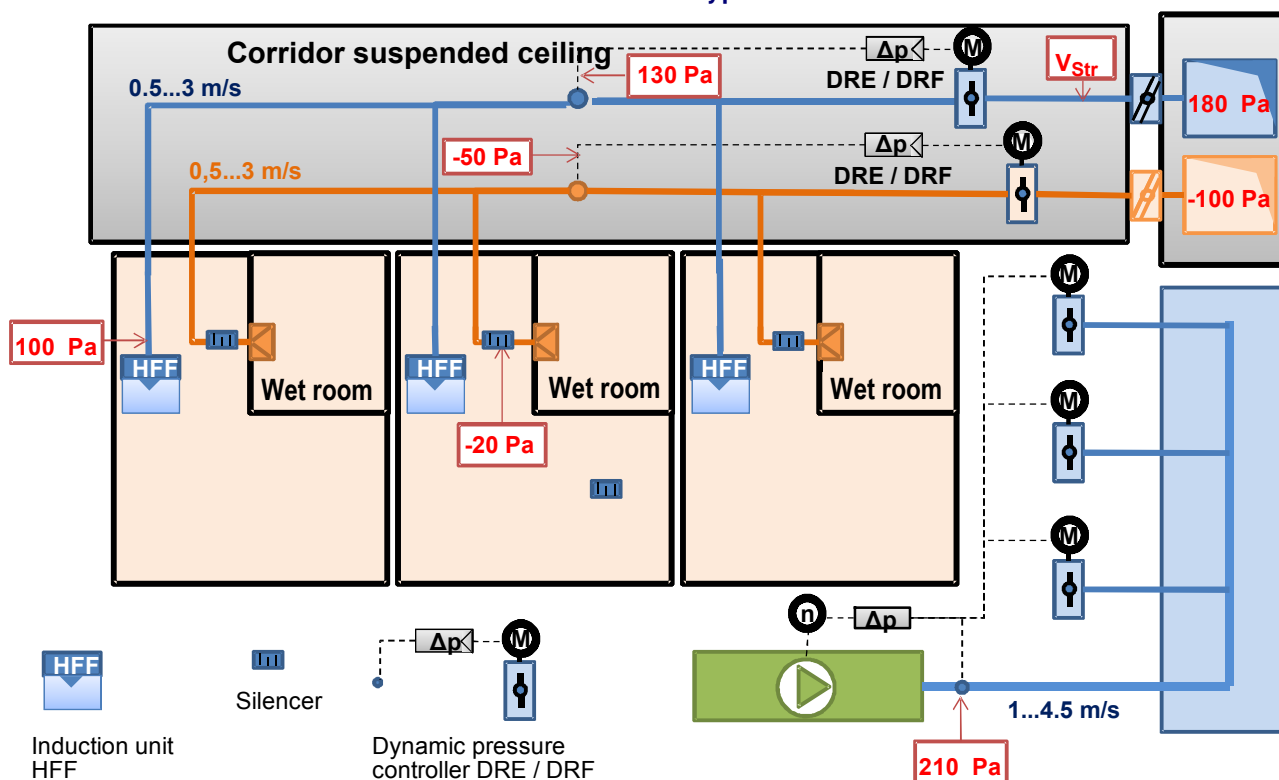

Technical brochure

Pressure controllers DRE

Function

The static pressure in the duct is measured. The required set value is compared with the actual value of the measurement point, and the control valve is operated accordingly until the actual value matches the set value.

Duct pressure or line pressure control

The pressure is measured relative to the environment, i.e. one port at the sensor remains open ("+" for waste air, "-" for supply air), and the other port is connected to the measurement point.

The pressure is regulated at the measurement point (in the air direction downstream of the controller). The set value must be specified depending on the downstream consumers (duct network calculation is essential!)

Materials, finishes

- Housing, damper and axle of galvanized steel
- Damper bearings of POM-plastic
- Sealings of EPDM

Accessories, special versions

- Pressure tapping set Mat. 673154, consisting of 2 air duct connection sockets with fastening accessories, 1 tube of \varnothing 5 mm x 7 (2 m long)
- Insulating case for sound and heat insulation
- Flanges according to DIN 24154 R1 at bot ends
- Flexible sound absorber type SDE-AO made of aluminium
- Rigid sound absorber type SDE-SO made of galvanized sheet steel

Additional accessories and special versions by request.

Application ranges, limits

- Dynamic measuring principle
- Control range 2...300 Pa
- $P_{nom} = 300$ Pa, height and tube length correction necessary
- $P_{min} = 0...100$ % of P_{nom}
- $P_{max} = 0...100$ % of P_{nom}
- Bursting pressure sensor = 1 bar
- Media temperature 0...+70 °C with 5...95 % rF, non condensing
- Ambient temperature 0...+50 °C
- Degree of contamination in environment: 3 (EN 60730-1)
- Position-independent installation
- Pressure connection: tube socket \varnothing inner 4...6 mm
- Leakage flow rate via shut damper blade Class4 acc. to DIN EN 1751 (DN 100 and DN 125: Class 3)
- Leakage flow rate via casing Class A acc. to DIN EN 1751, optional Class C
- Torque: 5 Nm
- Running time parametrizable, wit 5 NM = 15...120 s / 90 °
- Operating life: > 60 000 sequences (0 ° - 90 ° - 0 °)
- Manual adjustment: gear disengagement by pushbutton, self-resetting

Technical brochure

Pressure controllers DRE

Selection table for supply air / exhaust air pressure controllers

Rooms per line	Flow rate per line [m ³ /h]	Size DRE			
		[mm]			
		160	200	250	315
with 45 m³/h per room					
4	180	X	X		
6	270		X	X	
8	360		X	X	(X)
10	450			X	(X)
12	540				(X)
14	630				(X)
16	720				(X)
18	810				(X)
with 60 m³/h per room					
4	240	X	X	X	
6	360			X	(X)
8	480			X	(X)
10	600				(X)
12	720				(X)
14	840				(X)
16	960				
18	1080				

Correction values for various installation heights and tube lengths

Tube length [m]		0...10	11...20	21...30	31...40	41...50	51...60
		Correction values [%]					
height above sea level [m]	0...100	100	97.2	94.4	91.6	88.8	86.0
	101...200	98.8	96.0	93.2	90.4	87.6	84.8
	201...300	97.5	94.7	91.9	89.1	86.3	83.5
	301...400	96.3	93.5	90.7	87.9	85.1	82.3
	401...500	95.1	92.3	89.5	86.7	83.9	81.1
	501...600	93.9	91.1	88.3	85.5	82.7	79.9
	601...700	92.8	90.0	87.2	84.4	81.6	78.8
	701...800	91.6	88.8	86.0	83.2	80.4	77.6
	801...900	90.5	87.7	84.9	82.1	79.3	76.5
	901...1000	89.4	86.6	83.8	81.0	78.2	75.4
1001...1100	88.3	85.5	82.7	79.9	77.1	74.3	
1101...1200	87.2	84.4	81.6	78.8	76.0	73.2	

Technical brochure

Pressure controllers DRE

Dimensions, weight

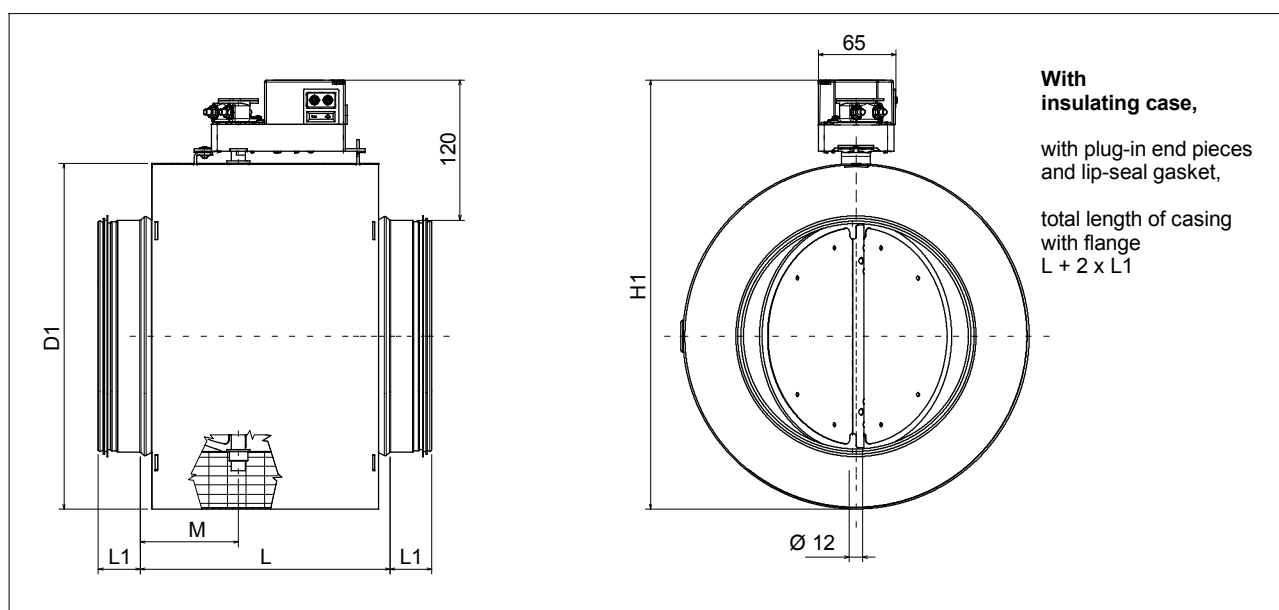
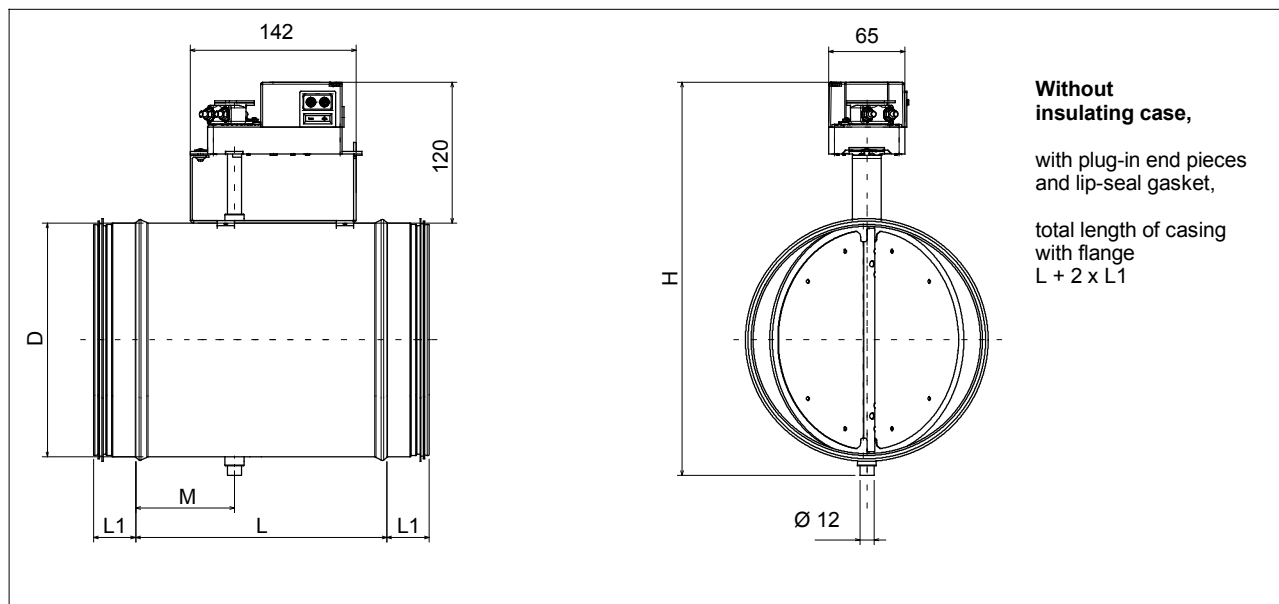

Nominal size DN	D [mm]	D1 [mm]	L [mm]	L1 [mm]	H [mm]	H1 [mm]	M [mm]	Damper angle [°]	Weight [kg]	
									without insulating case	with insulating case
100	100	200	195	36	235	270	64	60	1.5	2.9
125	125	225	195	36	260	295	64	60	1.8	3.4
160	160	260	215	36	295	330	84	60	2.1	4.1
200	200	300	215	36	335	370	84	60	2.6	4.9
250	250	350	260	54	385	415	130	60	3.3	6.5
315	315	415	260	54	450	485	130	60	4.4	8.2
400	400	500	315	72	535	570	175	60	6.1	11.7

Technical brochure

Pressure controllers DRE

Airborne sound transmission without silencer

Nominal size	Air speed. [m/s]	Flow rate [m³/h]	$\Delta p_{ges} = 100 \text{ Pa}$										$\Delta p_{ges} = 200 \text{ Pa}$									
			f_m [Hz]								Sum		f_m [Hz]								Sum	
			63	125	250	500	1 K	2 K	4 K	8 K	L_{WA} [dB(A)]	L_{pA} [dB(A)]	63	125	250	500	1 K	2 K	4 K	8 K	L_{WA} [dB(A)]	L_{pA} [dB(A)]
			L_W [dB/Okt]								L_W [dB/Okt]								L_{WA} [dB(A)]	L_{pA} [dB(A)]		
100	1	27	33	32	36	42	43	32	23	26	45	37	35	35	37	41	47	39	32	28	48	41
	4	108	39	48	44	42	41	35	31	27	45	37	42	51	50	48	50	46	47	42	54	46
	7	189	41	50	45	46	45	42	38	33	50	42	44	56	53	51	51	48	49	46	57	49
	10	272	44	51	48	50	49	47	42	43	54	46	47	58	56	55	54	53	49	52	60	52
125	1	43	32	29	31	39	41	32	23	16	42	35	37	29	33	41	49	44	37	29	51	43
	4	172	46	48	42	44	44	38	32	23	47	39	48	53	48	49	50	45	53	48	57	49
	7	299	50	54	48	49	50	42	40	36	53	45	52	61	54	54	55	49	53	51	60	52
	10	428	50	55	50	53	54	46	43	37	57	49	55	63	57	58	58	53	52	49	62	54
160	1	71	43	37	39	42	42	30	23	26	44	37	42	42	44	45	52	43	39	40	53	46
	4	284	49	50	46	46	46	36	29	26	48	41	52	54	53	52	53	46	39	34	55	48
	7	494	55	57	53	53	52	44	40	36	55	48	58	63	59	57	57	51	47	44	61	53
	10	706	58	60	56	57	57	49	45	40	60	51	62	66	63	61	61	55	51	49	65	56
200	1	111	38	33	37	40	39	31	21	15	42	34	41	37	41	46	49	45	36	28	51	44
	4	444	50	46	44	43	43	39	31	22	46	39	55	52	49	47	47	45	40	33	52	44
	7	776	58	53	50	50	51	46	40	37	54	44	62	59	57	54	54	51	47	48	58	49
	10	1108	65	60	58	57	57	53	48	54	61	51	66	63	61	58	58	56	51	56	63	52
250	1	174	38	39	42	43	39	33	28	26	44	36	39	42	45	50	50	46	38	31	53	46
	4	696	53	50	49	44	41	38	31	28	47	38	56	55	54	49	47	45	41	35	53	44
	7	1217	65	59	57	55	52	50	45	39	58	46	69	65	63	58	55	54	51	49	62	50
	10	1739	68	64	61	58	56	54	53	51	62	49	73	70	67	64	61	60	58	57	68	55
315	1	277	46	45	44	44	41	33	28	31	45	38	47	49	48	49	50	46	38	33	53	45
	4	1108	56	52	49	44	42	40	33	31	48	37	61	58	57	52	50	48	45	37	56	45
	7	1939	67	60	56	53	52	49	45	37	57	43	74	67	63	58	55	54	53	46	62	48
	10	2770	-	-	-	-	-	-	-	-	-	-	77	70	66	61	60	58	55	52	66	51
400	1	448	47	46	46	45	43	33	29	36	47	39	50	53	50	50	51	47	39	35	54	46
	4	1792	59	54	49	45	43	42	34	36	50	36	63	60	58	53	50	49	46	39	57	44
	7	3135	69	61	57	54	52	48	45	39	57	41	78	70	64	58	56	54	54	44	63	47
	10	4479	-	-	-	-	-	-	-	-	-	-	80	71	66	62	59	56	52	48	65	48

- Δp_{ges} - total pressure difference
- f_m - octave mid-band frequency
- L_W - sound power level
- L_{WA} - sound power level, A-weighted
- L_{pA} - sound pressure level, A-weighted

Technical brochure

Pressure controllers DRE

Airborne sound transmission with silencer type SDE-SO 900 mm long

Nominal size	Air speed. [m/s]	Flow rate [m³/h]	$\Delta p_{ges} = 100 \text{ Pa}$										$\Delta p_{ges} = 200 \text{ Pa}$									
			f_m [Hz]								Sum		f_m [Hz]								Sum	
			63	125	250	500	1 K	2 K	4 K	8 K	L_{WA} [dB(A)]	L_{pA} [dB(A)]	63	125	250	500	1 K	2 K	4 K	8 K	L_{WA} [dB(A)]	L_{pA} [dB(A)]
			L_W [dB/Okt]										L_W [dB/Okt]									
100	1	27	29	22	21	<15	<15	<15	<15	<15	16	<15	31	25	22	<15	<15	<15	<15	<15	17	<15
	4	108	33	28	25	17	<15	<15	<15	<15	20	<15	35	33	28	18	<15	<15	<15	<15	24	<15
	7	189	36	34	29	19	<15	<15	<15	<15	24	16	39	40	34	22	<15	<15	<15	17	30	20
	10	272	40	40	32	23	19	<15	<15	15	29	20	43	47	40	27	20	<15	<15	24	35	26
125	1	43	28	20	17	<15	<15	<15	<15	<15	<15	<15	33	20	19	<15	<15	<15	<15	<15	16	<15
	4	172	34	29	23	17	<15	<15	<15	<15	19	<15	39	31	27	20	<15	<15	<15	<15	24	<15
	7	299	40	37	29	21	<15	<15	<15	<15	27	17	45	42	35	25	<15	<15	<15	18	33	22
	10	428	46	45	35	26	21	17	<15	<15	33	24	51	53	42	31	22	17	17	24	40	30
160	1	71	40	32	28	19	<15	<15	<15	<15	23	<15	39	37	33	22	17	<15	<15	28	30	22
	4	284	45	40	34	24	<15	<15	<15	19	29	20	46	45	39	27	20	<15	<15	31	35	27
	7	494	50	47	39	29	18	<15	<15	23	35	26	52	53	45	33	23	<15	17	34	41	32
	10	706	55	55	45	34	25	19	17	27	42	31	59	61	52	38	28	21	21	36	48	37
200	1	111	37	28	27	21	<15	<15	<15	<15	22	<15	40	32	31	27	17	<15	20	17	28	21
	4	444	46	37	34	27	<15	<15	<15	17	29	21	48	41	38	31	20	18	25	26	34	26
	7	776	55	46	41	32	20	16	23	30	37	27	57	49	44	35	23	21	30	35	40	31
	10	1108	64	55	48	38	28	24	32	43	46	34	65	58	51	39	28	26	35	45	48	37
250	1	174	36	36	33	26	<15	<15	15	18	29	21	37	39	36	33	24	25	25	23	34	27
	4	696	46	44	39	31	19	19	23	26	37	26	48	48	43	38	28	30	32	32	41	32
	7	1217	56	53	46	36	25	26	32	35	45	30	60	58	51	42	31	34	38	40	47	36
	10	1739	66	61	52	41	32	33	40	43	50	36	71	67	58	47	35	39	45	49	56	42
315	1	277	45	43	38	29	20	18	20	24	33	25	46	47	42	34	29	31	30	26	39	31
	4	1108	55	50	44	33	25	26	28	27	40	28	59	56	49	38	31	35	37	32	46	35
	7	1939	66	58	50	38	31	34	37	30	47	32	73	65	57	43	34	39	45	39	54	39
	10	2770	76	65	56	42	37	42	45	33	57	38	86	74	64	47	37	43	52	45	61	46
400	1	448	46	44	41	32	28	25	26	34	38	30	49	51	45	37	36	39	50	33	49	44
	4	1792	57	52	47	37	33	33	34	36	44	30	63	60	52	41	39	43	51	38	53	40
	7	3135	68	59	52	41	37	40	42	37	50	34	77	68	59	45	41	46	51	42	58	41
	10	4479	79	66	57	46	42	47	50	38	59	39	91	76	66	49	44	49	51	46	62	46

- Δp_{ges} - total pressure difference
- f_m - octave mid-band frequency
- L_W - sound power level
- L_{WA} - sound power level, A-weighted
- L_{pA} - sound pressure level, A-weighted

Technical brochure Pressure controllers DRE

Casing sound emission without insulating case

Nominal size	Air speed. [m/s]	Flow rate [m ³ /h]	$\Delta p_{ges} = 100 \text{ Pa}$										$\Delta p_{ges} = 200 \text{ Pa}$									
			f_m [Hz]								Sum		f_m [Hz]								Sum	
			63	125	250	500	1 K	2 K	4 K	8 K	LWA [dB(A)]	LpA [dB(A)]	63	125	250	500	1 K	2 K	4 K	8 K	LWA [dB(A)]	LpA [dB(A)]
			L _W [dB/Okt]										L _W [dB/Okt]									
100	1	27	20	<15	18	25	28	23	<15	15	30	21	22	<15	19	23	31	31	20	17	35	26
	4	108	26	24	26	25	26	27	19	16	31	22	30	26	33	31	34	37	36	31	42	33
	7	189	28	25	28	28	30	34	26	23	37	28	31	31	36	34	36	40	38	36	45	36
	10	272	32	27	31	33	34	39	31	33	42	33	34	33	38	37	39	44	38	42	48	39
125	1	43	18	<15	<15	21	24	23	<15	<15	28	19	23	<15	<15	23	33	35	25	17	38	29
	4	172	33	23	24	26	27	29	19	<15	33	24	35	28	30	31	34	36	41	37	44	36
	7	299	37	29	29	31	33	33	27	25	38	29	39	36	36	36	38	40	41	40	47	38
	10	428	37	30	32	35	38	37	31	26	42	33	42	37	39	40	42	43	40	37	48	39
160	1	71	29	<15	20	23	25	20	<15	16	27	19	28	16	25	26	35	33	26	30	38	30
	4	284	35	24	27	27	29	26	16	16	32	23	38	28	34	33	36	36	26	24	40	32
	7	494	41	31	34	34	35	34	27	26	39	31	44	37	40	38	40	41	34	34	45	37
	10	706	44	34	37	38	40	39	32	30	44	35	48	40	44	42	44	45	38	39	49	41
200	1	111	28	<15	22	25	23	17	<15	<15	26	17	31	17	27	30	33	30	22	19	36	27
	4	444	40	27	30	28	27	24	16	<15	31	22	45	32	35	32	31	31	25	24	37	28
	7	776	48	34	36	35	35	31	26	28	39	30	52	40	43	39	37	37	33	39	44	35
	10	1108	55	41	44	42	41	39	34	45	48	39	56	44	47	43	42	41	36	47	50	41
250	1	174	27	19	27	27	22	18	<15	16	28	19	28	22	30	34	33	31	23	21	37	28
	4	696	42	30	34	28	24	23	16	18	31	22	45	35	39	33	30	30	26	25	37	28
	7	1217	54	39	42	39	35	35	30	29	42	33	58	45	48	42	38	39	36	39	47	38
	10	1739	57	44	46	42	39	39	38	41	47	38	62	50	52	48	44	45	43	47	53	44
315	1	277	34	24	28	30	26	21	16	24	31	22	35	28	32	35	35	34	26	26	39	31
	4	1108	44	31	33	30	27	28	21	24	34	25	49	37	41	38	35	36	33	30	42	33
	7	1939	55	39	40	39	37	37	33	30	43	34	62	46	47	44	40	42	41	39	49	40
	10	2770	-	-	-	-	-	-	-	-	-	-	65	49	50	47	45	46	43	45	52	44
400	1	448	34	24	29	34	31	24	20	32	36	27	37	31	33	39	39	38	30	31	43	35
	4	1792	46	32	32	34	31	33	25	32	38	29	50	38	41	42	38	40	37	35	46	37
	7	3135	56	39	40	43	40	39	36	35	46	37	65	48	47	47	44	45	45	40	52	43
	10	4479	-	-	-	-	-	-	-	-	-	-	67	49	49	51	47	47	43	44	54	45

Casing sound emission data given in the chart refer to the emitting jacket surface of a duct, total length 6 m, with the flow rate controller of galvanized sheet steel installed.

Due to resonance effects given frequency-related sound power level data may vary by ± 6 .

- Δp_{ges} - total pressure difference
- f_m - octave mid-band frequency
- L_W - sound power level
- L_{WA} - sound power level, A-weighted
- L_{pA} - sound pressure level, A-weighted

Technical brochure

Pressure controllers DRE

Casing sound emission with 50 mm insulating case

Nominal size	Air speed. [m/s]	Flow rate [m ³ /h]	$\Delta p_{ges} = 100 \text{ Pa}$										$\Delta p_{ges} = 200 \text{ Pa}$									
			f_m [Hz]								Sum		f_m [Hz]								Sum	
			63	125	250	500	1 K	2 K	4 K	8 K	L _{WA} [dB(A)]	L _{pA} [dB(A)]	63	125	250	500	1 K	2 K	4 K	8 K	L _{WA} [dB(A)]	L _{pA} [dB(A)]
			L _W [dB/Okt]										L _W [dB/Okt]									
100	1	27	19	<15	18	19	19	<15	<15	<15	21	<15	21	<15	19	17	22	<15	<15	<15	23	<15
	4	108	25	24	26	19	17	<15	<15	<15	22	<15	29	26	33	25	25	16	16	<15	29	20
	7	189	27	25	28	22	21	<15	<15	<15	25	16	30	31	36	28	27	19	18	16	32	23
	10	272	31	27	31	27	25	18	<15	<15	29	20	33	33	38	31	30	23	18	22	35	26
125	1	43	17	<15	18	17	16	<15	<15	<15	19	<15	22	<15	<15	17	24	<15	<15	<15	25	15
	4	172	32	23	24	20	18	<15	<15	<15	22	<15	34	28	30	25	25	15	21	17	29	20
	7	299	36	29	29	25	24	<15	<15	<15	28	18	38	36	36	30	29	19	21	20	34	25
	10	428	36	30	32	29	29	16	<15	<15	32	23	41	37	39	34	33	22	20	17	37	28
160	1	71	28	<15	20	17	16	<15	<15	<15	19	<15	27	16	25	20	26	<15	<15	<15	27	18
	4	284	34	24	27	21	20	<15	<15	<15	24	15	37	28	34	27	27	<15	<15	<15	30	21
	7	494	40	31	34	28	26	<15	<15	<15	30	21	43	37	40	32	31	20	<15	<15	35	27
	10	706	43	34	37	32	31	18	<15	<15	34	26	47	40	44	36	35	24	18	17	39	31
200	1	111	25	<15	20	22	20	<15	<15	<15	23	<15	28	15	25	27	30	24	<15	<15	32	23
	4	444	37	25	28	25	24	18	<15	<15	28	19	42	30	33	29	28	25	<15	<15	32	23
	7	776	45	32	34	32	32	25	<15	<15	35	26	49	38	41	36	34	31	<15	18	39	30
	10	1108	52	39	42	39	38	33	<15	24	42	33	53	42	45	40	39	35	<15	26	43	35
250	1	174	24	17	25	24	19	<15	<15	<15	24	15	25	20	28	31	30	25	<15	<15	33	24
	4	696	39	28	32	25	21	17	<15	<15	28	19	42	33	37	30	27	24	<15	<15	33	24
	7	1217	51	37	40	36	32	29	<15	<15	38	29	55	43	46	39	35	33	<15	18	42	33
	10	1739	54	42	44	39	36	33	16	20	42	33	59	48	50	45	41	39	21	26	47	38
315	1	277	31	22	26	24	20	<15	<15	<15	25	16	32	26	30	29	29	<15	<15	<15	33	22
	4	1108	41	29	31	24	21	20	<15	<15	28	19	46	35	39	32	29	<15	<15	<15	35	26
	7	1939	52	37	38	33	31	29	<15	<15	36	28	59	44	45	38	34	17	17	17	42	32
	10	2770	-	-	-	-	-	-	-	-	-	-	62	47	48	41	39	19	19	23	45	35
400	1	448	31	22	27	24	21	<15	<15	<15	25	16	34	29	31	29	29	<15	<15	<15	31	22
	4	1792	43	30	30	24	21	24	<15	<15	29	20	47	36	39	32	28	<15	<15	<15	34	25
	7	3135	53	37	38	33	30	30	<15	<15	37	28	62	46	45	37	34	20	20	<15	43	33
	10	4479	-	-	-	-	-	-	-	-	-	-	64	47	47	41	37	18	18	19	45	35

Casing sound emission data given in the chart refer to the emitting jacket surface of a duct, total length 6 m, with the flow rate controller of galvanized sheet steel installed.

Due to resonance effects given frequency-related sound power level data may vary by ± 6 .

- Δp_{ges} - total pressure difference
- f_m - octave mid-band frequency
- L_W - sound power level
- L_{WA} - sound power level, A-weighted
- L_{pA} - sound pressure level, A-weighted

Technical brochure

Pressure controllers DRE

Room sound pressure level calculation from controller sound transmission (excluding flow noise from the air diffusers)

System attenuation according to VDI 2081

f_m	[Hz]	63	125	250	500	1000	2000	4000	8000
Deflection $\Delta L_{W \text{ Okt}}$		0	0	1	2	3	3	3	3
Room attenuation $\Delta L_{W \text{ Okt}}$	[dB/Okt]	5	5	5	5	5	5	5	5
Outlet reflection $\Delta L_{W \text{ Okt}}$		10	5	2	0	0	0	0	0

Branching attenuation for distributing the sound power over multiple rooms, $V_{\text{room}} = 540 \text{ m}^3/\text{h}$

V	[m ³ /h]	540	1080	2160	5400	10800	16200	21600	25200	28800	32400	36000
$\Delta L_{W \text{ Okt}} = 10 \times Lg \frac{V}{540 \text{ m}^3/\text{h}}$	[dB/Okt]	0	3	6	10	13	14	16	17	17	18	19

Sample calculation sound transmission

Given: DRE 200 with silencer type SDE-SO 900 mm long

$V_{\text{max}} = 444 \text{ m}^3/\text{h}$, equates to 4 m/s

$\Delta p_{\text{ges}} = 200 \text{ Pa}$

$L_{WA} = 34 \text{ dB(A)}$

Required: room sound pressure level L_{pA} from controller sound transmission

Solution: f_m	[Hz]	63	125	250	500	1000	2000	4000	8000	Source
Sound power level $L_{W \text{ Okt}}$	[dB/Okt]	48	41	38	31	20	18	25	26	page 8
Deflection $\Delta L_{W \text{ Okt}}$	[dB/Okt]	0	0	-1	-2	-3	-3	-3	-3	page 11
Room attenuation $\Delta L_{W \text{ Okt}}$	[dB/Okt]	-5	-5	-5	-5	-5	-5	-5	-5	page 11
Outlet reflection $\Delta L_{W \text{ Okt}}$	[dB/Okt]	-10	-5	-2	0	0	0	0	0	page 11
Branching attenuation										
$\Delta L_{W \text{ Okt}} = 10 \times Lg \frac{444 \text{ m}^3/\text{h}}{540 \text{ m}^3/\text{h}}$	[dB/Okt]	0	0	0	0	0	0	0	0	page 11
A-weighting $\Delta L_{W \text{ Okt}}$	[dB/Okt]	-26	-16	-9	-3	0	1	1	-1	
A-weighted sound pressure level $L_{pA \text{ Okt}}$	[dB(A)/Okt]	<15	<15	20	21	<15	<15	17	16	
A-weighted sum sound pressure level $L_{pA} = 26 \text{ dB(A)}$										

Room sound pressure level calculation from controller radiation

f_m	[Hz]	63	125	250	500	1000	2000	4000	8000
Ceiling attenuation $\Delta L_{W \text{ Okt}}$	[dB/Okt]	4	4	4	4	4	4	4	4
Room attenuation $\Delta L_{W \text{ Okt}}$	[dB/Okt]	5	5	5	5	5	5	5	5

Sample calculation radiation

Given: DRE 200 without insulating case

$V_{\text{max}} = 444 \text{ m}^3/\text{h}$, equates to 4 m/s

$\Delta p_{\text{ges}} = 200 \text{ Pa}$

$L_{WA} = 37 \text{ dB(A)}$

Required: Room sound pressure level L_{pA} from controller radiation

Solution: f_m	[Hz]	63	125	250	500	1000	2000	4000	8000	Source
Sound power level $L_{W \text{ Okt}}$	[dB/Okt]	45	32	35	32	31	31	25	24	page 9
Ceiling attenuation $\Delta L_{W \text{ Okt}}$	[dB/Okt]	-4	-4	-4	-4	-4	-4	-4	-4	page 11
Room attenuation $\Delta L_{W \text{ Okt}}$	[dB/Okt]	-5	-5	-5	-5	-5	-5	-5	-5	page 11
A-weighting $\Delta L_{W \text{ Okt}}$	[dB/Okt]	-26	-16	-9	-3	0	1	1	-1	
A-weighted sound pressure level $L_{pA \text{ Okt}}$	[dB(A)/Okt]	<15	<15	17	20	22	23	17	<15	
A-weighted sum sound pressure level $L_{pA} = 28 \text{ dB(A)}$										

Technical brochure

Pressure controllers DRE

Nomenclature, ordering code

DRE 100 / S / D / L / G 227-05

(1) (2) (3) (4) (5) (6) (7) (8)

(1)	Series	DRE	= Pressure controller, round
(2)	Measuring principle		= dynamic
		-S	= static
(3)	Size resp. Ø	100	= 100
		125	= 125
		160	= 160
		200	= 200
		250	= 250
		315	= 315
		400	= 400
(4)	Version	S	= Galvanized steel
		E	= Stainless steel V4A
		K	= Coated
(5)	Insulating case	D	= With insulating case
		-	= Without insulating case
(6)	Connection	-	= Plug-in end piece without lip-seal gasket
		L	= Plug-in end piece with lip-seal gasket
		F	= Flanges acc. to DIN 24154 R1
		B	= Bord
(7)	Controller make	G	= Gruner
(8)	Controller type	227-05	= Gruner 227PMZ-024-05

Additional order specifications

- P_{min} [Pa]
- P_{max} [Pa]
- Mode 0...10 V or 2...10 V

Please notice: $P_{nenn} = 300$ Pa

$$P_{min} \geq 0$$

$$P_{min} \leq P_{max}$$

$$P_{max} \leq P_{nenn}$$

In the absence of such specifications the unit will be delivered with the following factory settings:







- $P_{min} = 0$ Pa
- $P_{max} = 300$ Pa
- Mode 0...10 V

Ordering example

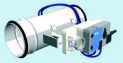
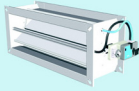
DRE 100/S/D/L/G227-05, $P_{min} = 0$ Pa, $P_{max} = 200$ Pa, Mode 2...10 V

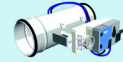
Product Overview LTG Air Distribution

Flow Rate Controllers



		Round		Square		
Variable		VRE _{active}	LTG Map Control System ActiveControl. Highest precision, short installation length		VRF _{active}	
		VRD _{active}				VRF
		VRE				To combine with customized drives; also available in PPS
		VRD				
Constant		VRW	Without external power supply, pollution-insensitive		VRX	Without external power supply, pollution-insensitive

All variable flow rate controllers are available with dynamic or static measuring principle

Pressure Controllers

		Round	Square		
	DRE	To balance extreme pressure level differences		DRF	To balance extreme pressure level differences

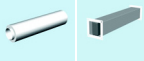
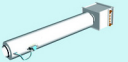
Special Products

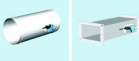
	SDE/SDF	Inline, cross-talk, and splitter silencers
	VRC+NE	Variable flow rate controller with silencer and reheating register
	VRW-A	Constant control and shut-off unit
	KLB	Ultra-tight shut-off damper (airtight acc. to DIN EN 1751: Class 4)
	ARE/ARF	Airtight shut-off damper (airtight acc. to DIN EN 1751: Class 4)

Engineering Services



LTG Engineering Services Comfort Air Technology

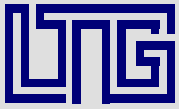

**AIR TECH
SYSTEMS**

Comfort Air Technology

Air-Water Systems
Air Diffusers
Air Distribution

Process Air Technology

Fans
Filtration technology
Humidification Technology

Engineering Services

Laboratory Test / Experiment
Field Measurement / Optimisation
Simulation / Analysis
R&D / Start-up

LTG Aktiengesellschaft

Grenzstraße 7
70435 Stuttgart
Germany
Tel.: +49 711 8201-0
Fax: +49 711 8201-720
info@LTG.de
www.LTG.net

LTG Incorporated

105 Corporate Drive, Suite E
Spartanburg, SC 29303
USA
Tel.: +1 864 599-6340
Fax: +1 864 599-6344
info@LTG-INC.net
www.LTG-INC.net