

Technical Brochure

LTG Air Distribution

Variable flow rate controllers
VRF active

active
control

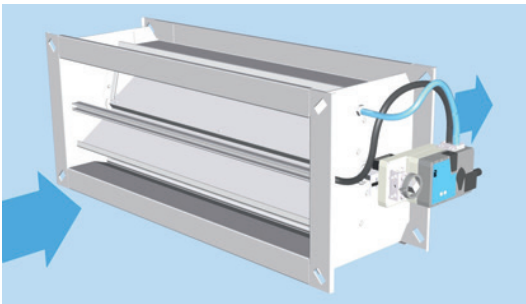

Square, with LTG map control
For comfort ventilation applications (e.g. office rooms)

Technical brochure • Variable flow rate controllers VRActive, square

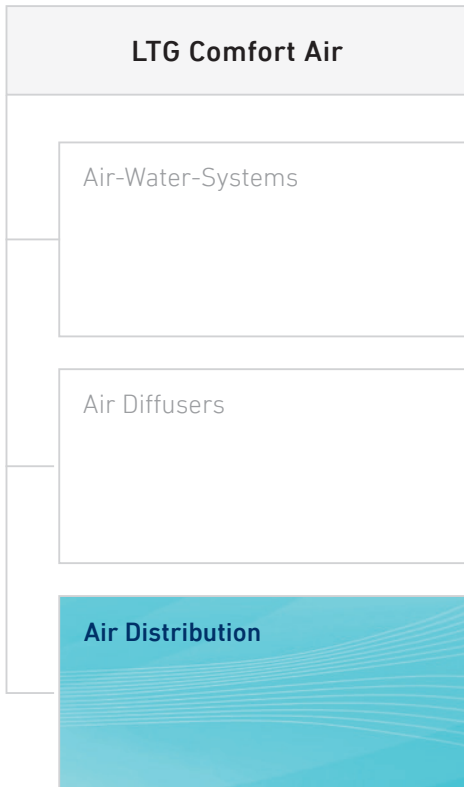

Content	Page
View of unit, application, measuring principle, benefits	4
General description, connection, selection, application ranges, control accuracy, installation recommendations	5
Dimensions, weights	6
Flow rates, minimum pressure differences	7
Airborne sound transmission	8
Casing radiation	10
Sample calculations	12
Nomenclature, ordering code	14

Notes

Dimensions stated in this brochure are subject to General Tolerances according to DIN ISO 2768-vL.

The actual specifications are available as a word document at your local distributor or at www.LTG.net.



The flow rate controllers VRE, VRF, VREactive and VRActive are designed to be installed in air-conditioning systems in accordance with VDI 2066 Sheets 1+2 and DIN 1946 Sheet 2.

The aforementioned standards, in particular DIN 1946-2 which has been superseded by DIN EN 13779, relate to DIN EN 13779, which in turn refer to the standards DIN EN 12237 and DIN EN 1507. The tightness classes quoted in the standards must be enquired depending on the product design.

LTG planning tools – we support you!

Visit the download area on our website www.LTG.net with helpful tools, such as dimensioning programs, streaming videos and product information!

Also available: Our product overviews about air diffusers, air-water systems, decentralised ventilation units and air distribution products.

DOWNLOADS

ProductNavigator & DocumentFinder



ProductNavigator
Please choose your desired product.



DocumentFinder
Please choose your desired type of documents.

Technical brochure • Variable flow rate controllers VRActive, square

Flow Rate Control Basics – Which Product for which Application?

Plant types

Variable Flow Rate

Units with variable flow rates (VVS) use electronic flow rate controllers providing the room with exactly the required air volume – according to function and energy efficiency.

Constant Flow Rate

Units with constant flow rates (KVS) use flow rate controllers maintaining a constant flow rate mechanically system-powered. Working with no wiring or external power supply, they provide convenient and cost-saving solutions.

Measuring Methods

Dynamic Differential Pressure Management

Dynamic methods measure part of the air that is guided through the differential pressure transducer. Dynamic differential pressure measuring makes economical sense in plants where no dust and/or chemical pollution of the air is expected, potentially leading to the contamination of sensors (e. g. administration and office buildings, museums, etc.).

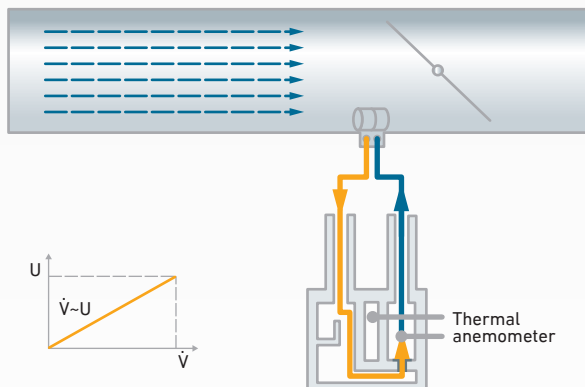

Static Differential Pressure Management

Static differential pressure measurement uses a diaphragm pressure transducer. With this method, no air is guided through the sensor, so no dust or chemical pollution by the air is possible and hence, may well be used in such environments.

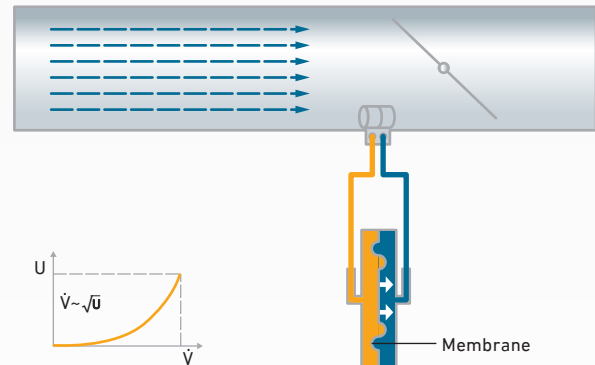

Both principles are applied in our products of VR... series: **VRActive** (dynamic) and **VRActive-s** (static).

LTG map control.

Differential pressure + Damper setting = Flow rate

Contrary to common measuring techniques, the differential pressure is not measured using an upstream element such as orifice plate or differential pressure sensor. Flow rate controllers VR.active measure the differential pressure directly in the damper blade area (stronger signal due to locally accelerated air flow).

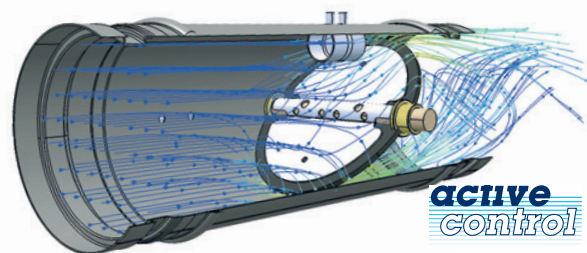

Locally accelerated air flow at the measuring point

Technical brochure • Variable flow rate controllers VRF^{active}, square

View of unit

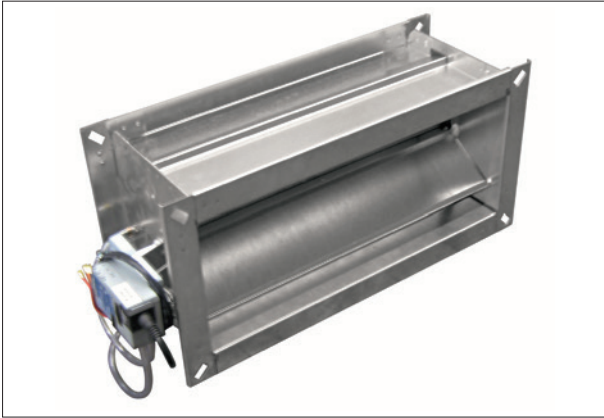

Application

The flow rate controller VRF^{active} has been designed for use in rectangular air ducts to electronically control flow rate based on constant or variable set values, independent of the pressure in the air duct. The damper has a very short installation case depth.

Casing sections match the recommended sizes for rectangular air ducts according to DIN EN 1505. Thus, the largest possible air flow section may be selected even in case of limited installation conditions.

Flow rate control has been designed for air speeds of 1...10 m/s. The flange is provided with oblong holes in the corners taking flat-flange air connections (DIN 24192) as well as Meinig, MEZ/SBM duct connections with a 30 mm resp. 40 mm section height.

Casing leakage meets DIN EN 1751 Class C and damper leakage Class 4 requirements (size 200 x 100: Class 3). All flow rate controllers are suitable for use with limit differential pressures of up to -750 Pa and +1000 Pa based on ambient pressure conditions.

Measuring principle

The flow rate is determined using two pressure-integrating measuring probes inside the duct casing. The measuring front probe determines the total pressure and the rear probe measures static pressure inside the jet-like damper-accelerated air flow. Thus, the resulting differential pressure is hydraulically amplified.

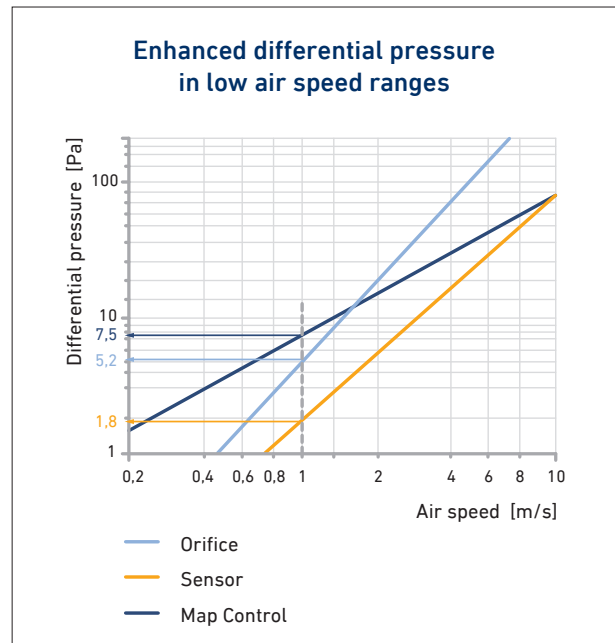

Output comparison of different measuring principles

Benefits

- Precision flow rate control at low air speeds (up to 1 m/s) compared to other hydraulic measuring techniques that rely on low pressure gauge/measurements.
- Improved differential pressure averaging of velocity profiles based by duct fittings
- Very short installation length thanks to measuring probe in the damper blade area
- Short entry flow duct requirement
- Excellent control accuracy of $\pm 5\%$ based on nominal flow rate
- Extended control range from 1...10 m/s
- Low loss of minimum pressure, leading to energy savings in operation and lower acoustic figures
- Low casing air leakage rate
- Damper offering complete shut-off facility
- Reduced pollution sensitivity due to 3 mm diameter pressure bores
- Damper position reading from outside

Technical brochure • Variable flow rate controllers VRActive, square

Materials, finishes

- Casing, damper and axle of galvanised steel
- Measuring probes of aluminium
- Damper bearings of POM plastic
- Sealings of EPDM

Accessories, special versions

- 40 mm thick insulating case of mineral wool with a 1 mm sheet steel jacket
- Sound absorbers, matched to the cross-section
- Compact controller compatible with MP-Bus, Modbus or BACnet
- Integrated NFC interface for diagnostic and parametrization via smartphone/app
- Service tool ZTH for diagnostic and parametrization

Additional accessories and special versions on request.

Recommendation for selection

- Air speed up to 7 m/s
- Damper pressure loss up to 500 Pa
- If sound emission via air duct surfaces is critical, all ducts including the controller must be sound insulated up to the sound absorber
- For sound absorbers, the flow noise downstream of the splitters and the noise created by the increased outflow air speed in the connected fittings must be considered

Application ranges and limits

- Minimum air speed 1 m/s
- Nominal air speed 10 m/s
- Maximum air speed in the free case section 12 m/s with specific factory-set adjustment
- Static over-pressure in the air duct up to 1000 Pa (Pressure Class 2, DIN EN 1507)
- Static under-pressure in the air duct based on ambient pressure -750 Pa max. (tightness Class C DIN EN 1507)
- Leakage flow rate via shut damper blade (standard version) Class 4 (size 200 x 100 Class 3) acc. to DIN EN 1751
- Leakage flow rate via casing Class C, acc. to DIN EN 1751
- Media temperature range 0 ... +50 °C, 5 ... 95 % rH, non condensing (acc. to EN 60730-1)
- Suitable for low-pollution air flows (e.g. ETA1, ETA2, acc. to DIN EN 13779), non-corrosive, aggressive air, without solvents that may affect the EPDM damper sealing
- Installation with horizontal damper axle only
- Free suction with upstream air duct or via fitting only

Connection

Notes and circuit diagrams for regulating the flow rate can be found in the operating and maintenance instructions.

Control accuracy, installation recommendations

Control accuracy is $\pm 5\%$ based on nominal flow rate. Due to measurement by the accelerated damper blade air flow the controller is virtually insensitive to entry duct conditions

Straight entry ducts are to be designed as follows: Length $\text{Min} > 2...3 H$ or $> 2...3 B$, depending on whether the disturbance is produced via the duct height H or width B .

If a combination of fittings that is unfavourable with view to the air flow is unavoidable, the minimum distance is several times the given Min .

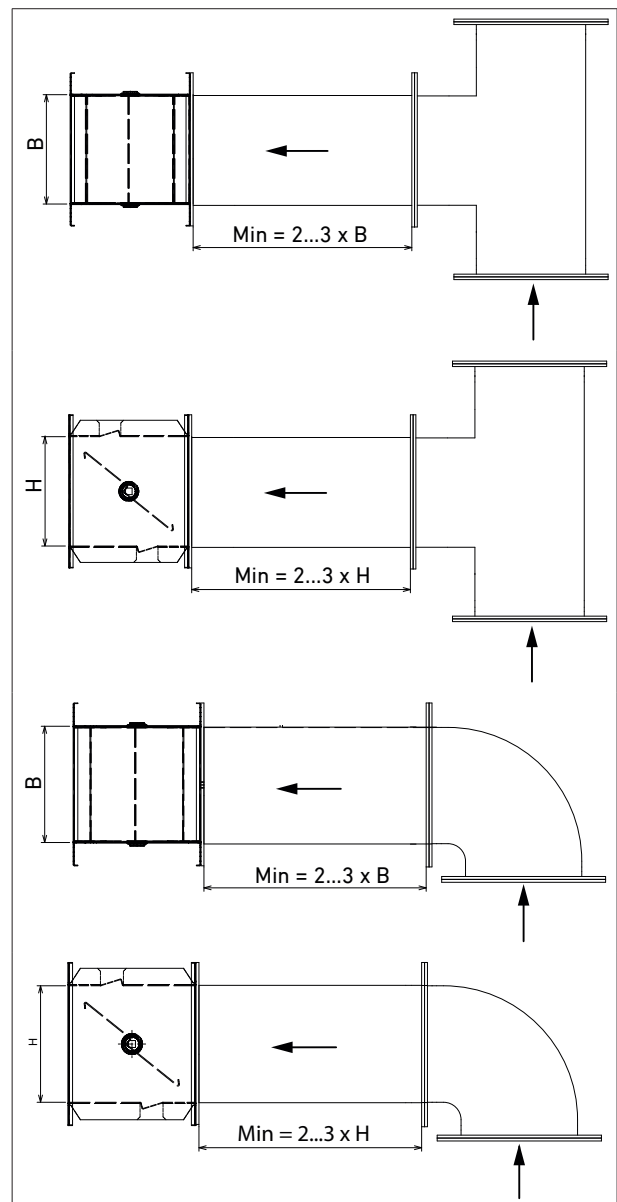

Technical brochure • Variable flow rate controllers VRActive, square

Dimensions, weights

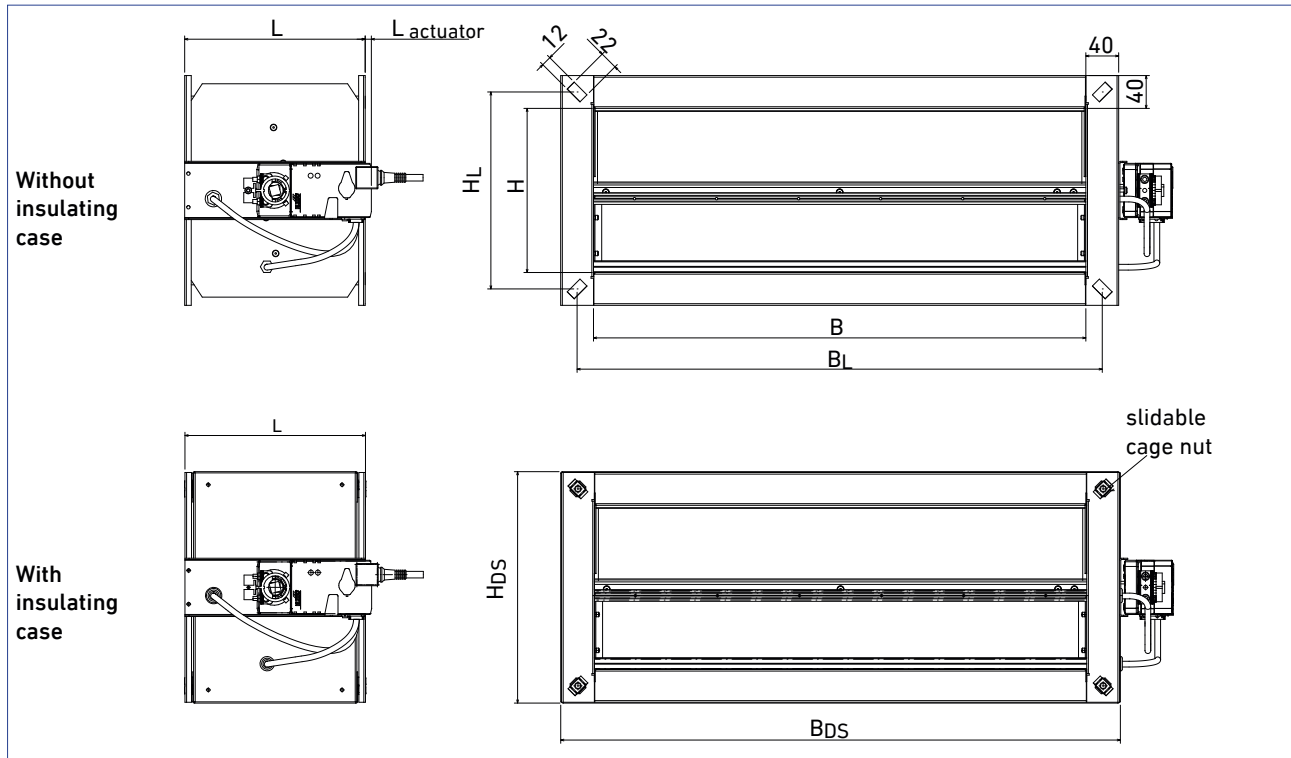

Width B [mm]	Height H [mm]	Length L [mm]	Distance between holes B _L [mm]	H _L [mm]	Excess length L _{actuator} [mm]	Width with insulation B _{DS} [mm]	Height with insulation H _{DS} [mm]	Max. torque [Nm]	Weight without with insulation [kg]	
200	100	135	240	140	60	282	182	5	3.0	4.3
300			340	140		382			3.7	5.5
400			440	140		482			4.4	6.5
500			540	140		582			5.1	7.5
600			640	140		682			5.8	8.3
300	150	170	340	190	60	382	232	5	4.4	6.5
400			440	190		482			5.2	7.6
500			540	190		582			6.0	8.8
600			640	190		682			6.8	10.2
200	200	220	240	240	30	282	282	5	4.3	6.7
300			340	240		382			5.3	8.3
400			440	240		482			6.3	9.5
500			540	240		582			7.3	11.2
600			640	240		682			8.3	12.4
800			840	240		882			10.2	15.2
300	250	270	340	290	30	382	332	5	6.3	11.3
400			440	290		482			7.4	12.3
500			540	290		582			8.5	15.4
600			640	290		682			9.6	17.5
800			840	290		882			11.6	21.8
300	300	325	340	340	0	382	382	10	7.8	13.0
400			440	340		482			9.2	15.5
500			540	340		582			10.2	17.5
600			640	340		682			12.8	20.0
800			840	340		882			15.7	23.5
1000			1040	340		1082			18.7	27.5
400	400	430	440	440	0	482	482	10	12.7	20.0
500			540	440		582			14.5	22.5
600			640	440		682			16.3	26.0
800			840	440		882			19.9	30.5
1000			1040	440		1082			23.5	35.0
1200			1240	440		1282			27.1	40.0

Technical brochure • Variable flow rate controllers VRActive, square

Flow rates, minimum pressure differences

Width B [mm]	Height H [mm]	at 1 m/s			at 2 m/s		at 4 m/s		at 7 m/s		at 10 m/s	
		V_{min} [m ³ /h]	V [m ³ /h]	Δp_{min} [Pa]	V [m ³ /h]	Δp_{min} [Pa]	V [m ³ /h]	Δp_{min} [Pa]	V [m ³ /h]	Δp_{min} [Pa]	V_{nom} [m ³ /h]	Δp_{min} [Pa]
200	100	72	144	10	288	20	504	40	720	80		
300		108	216		432	15	756	35	1080	70		
400		144	288		576		1008	30	1440	60		
500		180	360		720		1260					
600		216	432		864	1512	2160					
300	150	162	324	10	648	15	1134	20	1620	40		
400		216	432		864		1512		2160			
500		270	540		1080		1890		2700			
600		324	648		1296		2268		3240			
200	200	144	288	10	576	15	1008	20	1440	40		
300		216	432		864		1512		2160			
400		288	576		1152		2016		2880			
500		360	720		1440		2520		3600			
600		432	864		1728		3024		4320			
800		576	1152		2304		4032		5760			
300	250	270	540	10	1080	15	1890	20	2700	30		
400		360	720		1440		2520		3600			
500		450	900		1800		3150		4500			
600		540	1080		2160		3780		5400			
800		720	1440		2880		5040		7200			
300	300	324	648	10	1296	15	2268	20	3240	30		
400		432	864		1728		3024		4320			
500		540	1080		2160		3780		5400			
600		648	1296		2592		4536		6480			
800		864	1728		3456		6048		8640			
1000		1080	2160		4320		7560		10 800			
400	400	576	1152	10	2304	15	4032	20	5760	30		
500		720	1440		2880		5040		7200			
600		864	1728		3456		6048		8640			
800		1152	2304		4608		8064		11 520			
1000		1440	2880		5760		10 080		14 400			
1200		1728	3456		6912		12 096		17 280			

V - Flow rate

V_{min} - Minimum flow rate = lower limit of control

V_{nom} - Nominal flow rate

Δp_{min} - Minimum pressure loss

Technical brochure • Variable flow rate controllers VRActive, square

Airborne sound transmission without sound absorber

Width B [mm]	Height H [mm]	Air speed [m/s]	$\Delta p_{tot} = 100 \text{ Pa}$										$\Delta p_{tot} = 200 \text{ Pa}$										$\Delta p_{tot} = 500 \text{ Pa}$									
			f_m [Hz]								Sum		f_m [Hz]								Sum		f_m [Hz]								Sum	
			63	125	250	500	1 K	2 K	4 K	8 K	L_{WA} [dB(A)]	L_{pA} [dB(A)]	63	125	250	500	1 K	2 K	4 K	8 K	L_{WA} [dB(A)]	L_{pA} [dB(A)]	63	125	250	500	1 k	2 K	4 K	8 K	L_{WA} [dB(A)]	L_{pA} [dB(A)]
			L_W [dB/Okt]								L_W [dB/Okt]								L_W [dB/Okt]													
300	100	1	31	31	40	43	40	33	31	29	44	37	36	34	42	47	46	42	38	37	50	42	39	46	45	49	51	50	48	47	56	48
		2	37	38	45	41	42	39	34	31	46	38	39	39	49	50	48	46	43	40	53	45	43	43	49	55	55	54	52	52	61	53
		4	41	45	46	42	43	40	38	33	47	40	42	45	51	49	49	49	46	42	55	47	44	45	53	57	60	56	56	54	64	56
		7	56	58	55	50	48	45	43	38	54	45	52	55	59	54	53	51	52	52	59	51	51	53	60	60	61	59	60	59	67	58
		10	59	60	59	55	55	53	47	41	60	49	61	63	62	61	60	57	53	51	65	54	56	59	66	62	63	60	61	60	68	58
400	150	1	42	43	46	48	45	43	36	38	50	42	47	46	50	52	51	50	44	42	56	48	48	49	55	59	58	58	60	56	65	58
		2	46	50	50	47	45	47	39	39	52	44	49	51	57	56	52	53	58	49	62	54	54	55	59	62	61	61	67	60	70	62
		4	54	56	54	51	49	48	43	40	55	45	57	61	63	58	54	54	59	52	63	54	62	63	67	70	63	61	63	68	72	63
		7	60	60	58	54	52	49	45	42	57	46	64	66	66	61	58	56	58	53	65	53	69	70	74	72	66	64	64	70	75	63
		10	65	64	62	58	57	52	48	45	61	48	72	70	69	64	61	58	56	54	67	53	74	76	78	75	68	66	66	72	77	64
600	200	1	48	47	51	49	53	53	40	39	57	49	52	48	57	55	54	65	48	44	67	59	56	52	61	63	61	69	55	55	71	63
		2	55	47	50	54	53	57	46	41	60	50	55	50	57	56	56	60	56	47	64	54	60	51	59	65	63	67	68	59	72	63
		4	60	51	52	53	54	55	47	40	59	46	64	58	59	61	59	60	57	52	65	53	70	61	64	66	66	67	68	63	73	61
		7	61	60	57	56	54	55	48	44	60	45	70	62	61	63	60	61	60	58	67	53	78	71	71	71	71	69	69	66	76	62
		10	63	59	57	58	54	51	48	45	60	43	77	66	64	64	61	62	58	55	68	51	80	75	74	73	71	69	68	69	77	60
600	250	1	49	48	51	50	55	53	40	39	58	50	52	50	57	56	56	65	49	45	67	59	57	53	62	64	62	69	58	56	72	64
		2	55	49	52	55	55	56	45	41	60	49	56	52	57	58	58	61	55	47	65	54	61	54	62	67	65	69	67	59	74	63
		4	59	52	54	55	55	55	47	44	60	46	64	59	61	63	61	60	57	52	66	53	70	63	65	67	68	69	68	62	75	61
		7	63	61	58	57	55	55	49	45	61	45	71	64	63	64	62	62	60	59	68	53	79	72	72	72	72	70	69	67	77	61
		10	65	62	59	59	56	53	51	49	61	44	77	68	66	65	63	62	58	57	69	51	82	77	75	73	73	70	69	69	78	60
600	300	1	51	48	52	52	57	53	40	39	59	51	53	51	58	57	59	65	50	45	67	58	58	55	63	66	64	70	60	57	73	64
		2	55	50	54	57	56	55	44	41	61	49	57	53	57	60	61	61	54	48	66	54	62	57	64	68	67	71	66	59	75	63
		4	58	53	57	57	56	55	47	47	61	46	65	60	62	64	62	61	56	51	67	52	70	64	65	68	71	71	68	62	76	61
		7	64	62	60	59	57	56	50	46	62	46	71	65	64	65	63	62	60	59	69	52	79	73	72	73	74	71	69	67	78	61
		10	68	65	61	60	57	54	53	52	63	44	77	70	67	67	64	63	59	58	70	51	83	78	75	74	74	71	70	69	79	60
800	400	1	55	50	53	56	61	53	42	40	62	52	54	55	60	59	65	65	52	47	69	58	60	59	66	70	68	72	66	61	76	67
		2	57	53	59	60	59	55	43	42	63	49	60	57	59	65	67	64	53	49	70	56	65	63	69	72	72	77	64	60	80	68
		4	57	57	62	61	58	56	48	55	64	47	67	63	65	69	67	62	55	52	71	54	72	68	67	71	76	76	69	62	81	65
		7	67	65	64	63	61	59	54	49	66	46	73	69	67	68	67	65	61	60	72	52	82	76	74	76	78	74	70	69	81	65
		10	73	72	66	63	61	58	58	60	67	47	78	74	70	70	69	65	61	61	73	53	86	81	77	75	77	74	72	70	81	62

Conversion to other model sizes is realised at the same throttle point of air speed and pressure loss using the ΔL values from the following chart. The values are applicable to the associated unit height H.

$$L_{W \text{ Okt}} = L_{W \text{ Chart}} + \Delta L$$

$$L_{WA} = L_{WA \text{ Chart}} + \Delta L$$

Δp_{tot} - Total pressure diff.

f_m - Octave mid-band frequency

L_W - Sound power level

L_{WA} - Sound power level, A-weighted

L_{pA} - Sound pressure level, A-weighted

Width B [mm]	Height H [mm]					
	100	150	200	250	300	400
200	-2		-5			
300	0	-1	-3	-3	-3	
400	1	0	-2	-2	-2	-3
500	2	1	-1	-1	-1	-2
600	3	2	0	0	0	-1
800			1	1	1	0
1000				2	2	1
1200					3	2

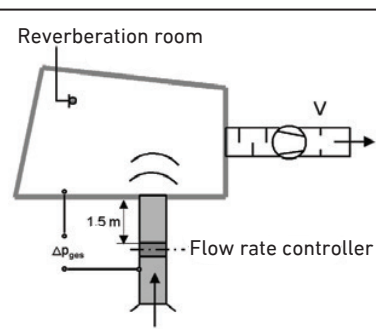

Technical brochure • Variable flow rate controllers VRActive, square

Airborne sound transmission with sound absorber

Width B [mm]	Height H [mm]	Air speed [m/s]	$\Delta p_{tot} = 100 \text{ Pa}$										$\Delta p_{tot} = 200 \text{ Pa}$										$\Delta p_{tot} = 500 \text{ Pa}$												
			f_m [Hz]								Sum		f_m [Hz]								Sum		f_m [Hz]								Sum				
			63	125	250	500	1 K	2 K	4 K	8 K	L_W [dB/Okt]	L_{WA} [dB(A)]	L_{pA} [dB(A)]	63	125	250	500	1 K	2 K	4 K	8 K	L_W [dB/Okt]	L_{WA} [dB(A)]	L_{pA} [dB(A)]	63	125	250	500	1 k	2 K	4 K	8 K	L_W [dB/Okt]	L_{WA} [dB(A)]	L_{pA} [dB(A)]
			L_W [dB/Okt]								L_{WA} [dB(A)]	L_{pA} [dB(A)]	L_W [dB/Okt]								L_{WA} [dB(A)]	L_{pA} [dB(A)]	L_W [dB/Okt]								L_{WA} [dB(A)]	L_{pA} [dB(A)]			
300	100	1	29	27	32	26	7	1	13	15	27	19	34	30	34	30	13	10	20	23	31	23	37	42	37	32	18	18	30	33	37	29			
		2	35	34	37	24	9	7	16	17	30	22	37	35	41	33	15	14	25	26	36	28	41	39	41	38	22	22	34	38	41	33			
		4	39	41	38	25	10	8	20	19	32	24	40	41	43	32	16	17	28	28	37	29	42	41	45	40	27	24	38	40	44	36			
		7	54	54	47	33	15	13	25	24	42	32	50	51	51	37	20	19	34	38	45	36	49	49	52	43	28	27	42	45	49	40			
		10	57	56	51	38	22	21	29	27	45	34	59	59	54	44	27	25	35	37	49	38	54	55	58	45	30	28	43	46	52	41			
400	150	1	40	39	38	31	12	11	18	24	33	25	45	42	42	35	18	18	26	28	37	29	46	45	47	42	25	26	42	42	47	39			
		2	44	46	42	30	12	15	21	25	36	28	47	47	49	39	19	21	40	35	45	37	52	51	51	45	28	29	49	46	52	44			
		4	52	52	46	34	16	16	25	26	41	30	55	57	55	41	21	22	41	38	49	39	60	59	59	53	30	29	45	54	57	47			
		7	58	56	50	37	19	17	27	28	45	32	62	62	58	44	25	24	40	39	52	40	67	66	66	55	33	32	46	56	61	49			
		10	63	60	54	41	24	20	30	31	49	34	70	66	61	47	28	26	38	40	55	41	72	72	70	58	35	34	48	58	64	50			
600	200	1	46	43	43	32	20	21	22	25	37	29	50	44	49	38	21	33	30	30	43	35	54	48	53	46	28	37	37	41	49	41			
		2	53	43	42	37	20	25	28	27	39	29	53	46	49	39	23	28	38	33	44	34	58	47	51	48	30	35	50	45	53	43			
		4	58	47	44	36	21	23	29	26	40	26	62	54	51	44	26	28	39	38	47	34	68	57	56	49	33	35	50	49	55	42			
		7	59	56	49	39	21	23	30	30	45	29	68	58	53	46	27	29	42	44	51	35	76	67	63	54	38	37	51	52	60	44			
		10	61	55	49	41	21	19	30	31	45	27	75	62	56	47	28	30	40	41	53	35	78	71	66	56	38	37	50	55	62	44			
600	250	1	47	44	43	33	22	21	22	25	37	29	50	46	49	39	23	33	31	31	43	35	55	49	54	47	29	37	40	42	50	42			
		2	53	45	44	38	22	24	27	27	40	29	54	48	49	41	25	29	37	33	45	34	59	50	54	50	32	37	49	45	53	43			
		4	57	48	46	38	22	23	29	30	41	27	62	55	53	46	28	28	39	38	49	35	68	59	57	50	35	37	50	48	55	41			
		7	61	57	50	40	22	23	31	31	46	29	69	60	55	47	29	30	42	45	52	35	77	68	64	55	39	38	51	53	60	44			
		10	63	58	51	42	23	21	33	35	47	28	75	64	58	48	30	30	40	43	55	35	80	73	67	56	40	38	51	55	63	44			
600	300	1	49	44	44	35	24	21	22	25	38	29	51	47	50	40	26	33	32	31	44	35	56	51	55	49	31	38	42	43	51	42			
		2	53	46	46	40	23	23	26	27	41	29	55	49	49	43	28	29	36	34	45	33	60	53	56	51	34	39	48	45	54	42			
		4	56	49	49	40	23	23	29	33	43	28	63	56	54	47	29	29	38	37	49	34	68	60	57	51	38	39	50	48	56	41			
		7	62	58	52	42	24	24	32	32	47	30	69	61	56	48	30	30	42	45	53	35	77	69	64	56	41	39	51	53	61	43			
		10	66	61	53	43	24	22	35	38	49	29	75	66	59	50	31	31	41	44	56	36	81	74	67	57	41	39	52	55	64	44			
800	400	1	53	46	45	39	28	21	24	26	40	30	52	51	52	42	32	33	34	33	46	35	58	55	58	53	35	40	48	47	55	44			
		2	55	49	51	43	26	23	25	28	45	31	58	53	51	48	34	32	35	35	48	34	63	59	61	55	39	45	46	46	57	43			
		4	55	53	54	44	25	24	30	41	48	31	65	59	57	52	34	30	37	38	53	36	70	64	59	54	43	44	51	48	58	41			
		7	65	61	56	46	28	27	36	35	51	30	71	65	59	51	34	33	43	46	55	35	80	72	66	59	45	42	52	55	63	43			
		10	71	68	58	46	28	26	40	46	55	33	76	70	62	53	36	33	43	47	59	37	84	77	69	58	44	42	54	56	66	44			

The values on which the attenuation is based are applicable to an active sound absorber length of 1000 mm. Conversion to other model sizes is realised at the same throttle point of air speed and pressure loss using the ΔL values from the following chart. The values are applicable to the associated unit height H.

$$L_{W \text{ Okt}} = L_{W \text{ Chart}} + \Delta L$$

$$L_{WA} = L_{WA \text{ Chart}} + \Delta L$$

- Δp_{tot} - Total pressure difference
- f_m - Octave mid-band frequency
- L_W - Sound power level
- L_{WA} - Sound power level, A-weighted
- L_{pA} - Sound pressure level, A-weighted

Width B [mm]	Height H [mm]					
	100	150	200	250	300	400
200	-2		-5			
300	0	-1	-3	-3	-3	
400	1	0	-2	-2	-2	-3
500	2	1	-1	-1	-1	-2
600	3	2	0	0	0	-1
800			1	1	1	0
1000				2	2	1
1200					3	2

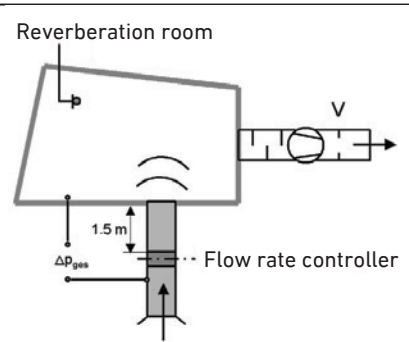

Technical brochure • Variable flow rate controllers VRActive, square

Casing radiation without insulating case

Width B [mm]	Height H [mm]	Air speed [m/s]	$\Delta p_{tot} = 100 \text{ Pa}$										$\Delta p_{tot} = 200 \text{ Pa}$										$\Delta p_{tot} = 500 \text{ Pa}$												
			f_m [Hz]								Sum		f_m [Hz]								Sum		f_m [Hz]								Sum				
			63	125	250	500	1 K	2 K	4 K	8 K	L_W [dB/Okt]	L_{WA} [dB(A)]	L_{pA} [dB(A)]	63	125	250	500	1 K	2 K	4 K	8 K	L_W [dB/Okt]	L_{WA} [dB(A)]	L_{pA} [dB(A)]	63	125	250	500	1 k	2 K	4 K	8 K	L_W [dB/Okt]	L_{WA} [dB(A)]	L_{pA} [dB(A)]
			L_W [dB/Okt]								L_{WA} [dB(A)]	L_{pA} [dB(A)]	L_W [dB/Okt]								L_{WA} [dB(A)]	L_{pA} [dB(A)]	L_W [dB/Okt]								L_{WA} [dB(A)]	L_{pA} [dB(A)]			
300	100	1	41	38	39	34	31	23	21	22	36	27	46	41	41	38	37	32	28	30	41	32	49	53	44	40	42	40	38	40	48	39			
		2	46	45	44	32	33	28	24	24	39	30	48	46	48	41	39	36	33	33	45	36	52	51	48	46	46	44	42	45	52	43			
		4	51	52	45	33	33	30	28	26	42	32	52	52	50	40	40	38	36	36	47	38	53	52	52	48	50	46	46	47	55	46			
		7	65	65	54	41	39	35	33	31	52	43	61	62	57	45	44	41	42	45	53	44	60	60	59	51	52	49	50	52	58	50			
10	69	67	58	46	46	43	37	34	55	46	71	70	61	52	51	47	43	44	59	50	65	67	64	53	54	50	51	53	61	52					
400	150	1	47	46	42	38	35	32	26	31	41	32	52	49	46	42	41	40	34	35	47	38	53	53	50	49	48	47	50	49	56	47			
		2	51	54	46	37	35	37	29	32	44	35	54	55	53	46	42	43	48	42	53	44	59	59	55	52	52	51	57	53	61	52			
		4	59	60	50	41	39	37	33	33	48	39	62	65	59	48	45	44	49	45	56	47	67	66	63	59	53	51	53	61	64	55			
		7	65	64	54	44	43	38	34	35	52	43	69	69	62	51	48	46	48	46	59	50	74	74	70	62	56	54	54	63	67	58			
10	70	68	58	48	47	42	38	38	56	47	77	73	65	54	51	48	46	47	62	53	79	79	74	65	59	56	56	65	71	62					
600	200	1	51	49	46	38	44	43	30	32	48	39	56	51	52	45	44	55	38	37	57	48	60	54	56	52	51	59	45	48	61	52			
		2	59	50	46	43	44	47	36	34	50	42	59	52	52	45	46	50	46	40	54	45	64	54	55	55	53	56	57	52	63	53			
		4	64	53	48	43	44	45	37	33	50	41	67	60	55	50	49	49	47	45	56	47	74	64	59	56	56	56	57	56	64	55			
		7	65	63	52	45	44	44	38	37	52	43	74	65	57	52	51	50	50	51	59	50	82	73	67	61	61	59	58	59	68	59			
10	67	62	52	47	45	41	38	38	52	43	81	69	60	54	51	51	47	48	61	52	84	78	69	63	62	59	58	62	69	60					
600	250	1	52	49	46	40	46	43	30	32	49	40	55	51	52	45	47	55	39	38	57	48	60	55	57	54	53	59	48	50	62	53			
		2	58	50	47	45	45	46	35	34	51	42	59	53	52	47	49	51	45	41	55	46	64	56	57	56	55	59	57	52	64	55			
		4	62	54	50	45	45	45	37	37	51	42	67	61	56	52	51	50	47	45	57	48	73	65	60	57	59	59	58	55	65	56			
		7	66	63	53	47	46	45	39	38	53	44	74	66	58	53	52	51	50	52	60	51	82	73	67	62	63	60	59	60	68	60			
10	68	64	54	48	46	43	41	42	54	45	80	70	61	55	53	52	48	50	61	52	85	78	70	63	63	60	59	62	70	61					
600	300	1	53	49	46	41	47	42	30	32	50	40	55	52	53	46	49	54	40	38	57	48	60	56	58	55	54	60	50	51	63	54			
		2	58	51	49	46	46	45	34	34	51	42	60	54	52	49	51	51	44	41	56	47	65	58	59	57	57	61	56	52	65	56			
		4	60	55	51	46	46	45	37	40	52	43	67	61	56	54	53	50	46	45	58	49	73	65	60	58	61	61	58	55	66	58			
		7	66	63	55	48	47	46	40	39	54	45	73	67	59	54	54	52	50	52	60	51	82	74	67	62	64	61	59	60	69	60			
10	70	67	56	49	48	44	43	45	56	47	79	71	62	56	55	53	49	51	62	53	85	79	70	63	64	61	60	62	71	62					
800	400	1	55	50	47	45	51	43	32	33	53	44	54	54	54	48	56	55	42	40	59	51	60	58	60	69	58	61	56	54	68	59			
		2	57	53	53	49	50	44	33	35	53	44	60	57	53	54	57	53	43	42	60	51	66	62	64	61	63	67	54	53	70	61			
		4	57	57	56	50	49	46	38	48	55	46	67	63	59	58	57	52	45	45	61	52	72	67	62	60	66	66	59	55	71	62			
		7	68	65	58	52	51	49	44	42	57	48	73	69	61	57	57	55	51	53	63	54	82	76	68	65	68	63	60	62	72	63			
10	73	72	61	52	51	48	48	53	60	52	78	74	65	59	59	55	51	54	65	56	86	81	71	64	67	64	62	63	73	64					

Conversion to other model sizes is realised at the same throttle point of air speed and pressure loss using the ΔL values from the following chart. The values are applicable to the associated unit height H.

$$L_{W \text{ Okt}} = L_{W \text{ Chart}} + \Delta L$$

$$L_{WA} = L_{WA \text{ Chart}} + \Delta L$$

Δp_{tot}	Width B [mm]	Height H [mm]					
		100	150	200	250	300	400
f_m	200	-2		-5			
	300	0	-1	-3	-3	-3	
L_W	400	1	0	-2	-2	-2	-3
L_{WA}	500	2	1	-1	-1	-1	-2
	600	3	2	0	0	0	-1
L_{pA}	800			1	1	1	0
	1000				2	2	1
	1200					3	2

Controller and air duct without insulating case

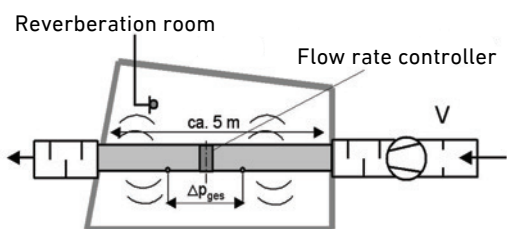

Technical brochure • Variable flow rate controllers VRActive, square

Casing radiation with insulating case

Width B [mm]	Height H [mm]	Air speed [m/s]	$\Delta p_{tot} = 100 \text{ Pa}$												$\Delta p_{tot} = 200 \text{ Pa}$												$\Delta p_{tot} = 500 \text{ Pa}$											
			f_m [Hz]								Sum		f_m [Hz]								Sum		f_m [Hz]								Sum							
			63	125	250	500	1 K	2 K	4 K	8 K	L_{WA} [dB(A)]	L_{pA} [dB(A)]	63	125	250	500	1 K	2 K	4 K	8 K	L_{WA} [dB(A)]	L_{pA} [dB(A)]	63	125	250	500	1 k	2 K	4 K	8 K	L_{WA} [dB(A)]	L_{pA} [dB(A)]						
			L_W [dB/Okt]								L_W [dB/Okt]								L_W [dB/Okt]																			
300	100	1	33	31	32	25	19	9	5	4	27	18	38	34	34	29	24	18	13	11	31	22	41	46	37	31	30	26	23	21	36	27						
		2	39	38	37	23	21	15	9	5	30	22	41	39	41	31	27	22	18	14	35	26	45	43	41	37	34	30	27	26	40	31						
		4	43	45	38	24	21	17	13	7	33	24	44	45	43	31	28	25	21	17	37	28	46	45	45	39	38	33	31	29	43	34						
		7	58	58	47	32	27	21	18	12	44	35	54	55	50	36	32	27	26	26	45	35	53	53	52	42	39	35	35	33	47	38						
		10	62	60	51	37	34	29	22	15	47	38	63	63	54	43	39	33	28	26	50	41	58	60	57	44	41	37	36	35	51	42						
400	150	1	40	39	35	29	23	19	11	12	31	22	45	42	39	33	29	26	19	16	36	27	45	46	43	40	36	34	35	30	43	34						
		2	43	47	39	28	23	23	14	13	35	26	47	48	46	37	30	29	33	23	41	33	52	52	48	43	40	37	41	34	48	39						
		4	51	52	43	32	27	24	18	14	39	30	55	58	52	38	32	30	34	26	47	38	60	59	56	50	41	38	38	42	52	43						
		7	57	57	47	35	31	25	19	17	44	35	61	62	55	42	36	32	33	28	50	41	66	67	63	53	44	40	39	45	57	49						
		10	63	60	51	38	35	28	23	19	48	38	69	66	58	44	39	34	31	28	54	45	72	72	67	56	47	42	41	46	61	53						
600	200	1	44	42	39	29	32	29	15	13	37	28	48	44	45	36	32	41	23	18	44	35	53	47	49	43	39	45	30	30	49	40						
		2	51	43	39	34	32	33	20	15	39	30	52	45	45	36	34	36	31	21	42	33	56	47	48	46	41	43	42	33	49	41						
		4	57	46	41	34	32	31	22	14	39	30	60	53	48	41	37	36	32	26	45	36	66	57	52	47	44	43	42	37	52	43						
		7	58	56	45	36	32	31	22	19	43	34	66	58	50	43	39	37	35	33	48	39	74	66	60	52	49	45	43	40	57	48						
		10	59	55	45	38	32	27	23	19	43	34	73	62	53	44	39	38	32	30	52	43	77	71	62	53	50	46	43	43	60	51						
600	250	1	45	42	39	31	33	29	15	14	37	28	48	44	45	36	35	41	24	19	44	35	53	48	50	45	41	45	33	31	50	40						
		2	51	43	40	36	33	32	20	16	39	30	52	46	45	38	37	37	30	22	43	34	57	49	50	47	43	45	42	34	51	42						
		4	55	47	43	35	33	31	22	18	40	31	60	54	49	43	39	36	32	26	46	37	66	57	53	48	47	45	43	37	53	44						
		7	58	56	46	38	34	32	24	20	44	35	66	59	51	44	40	38	35	33	49	40	74	66	60	53	50	46	44	41	58	49						
		10	61	57	47	39	34	29	25	23	45	36	73	63	54	46	41	39	33	31	52	43	77	71	63	54	51	47	44	44	60	51						
600	300	1	46	42	39	32	35	29	15	14	38	29	47	45	46	37	37	41	25	19	45	36	53	49	51	46	42	46	35	32	50	42						
		2	50	44	42	37	34	31	19	15	40	31	52	47	45	40	39	38	29	22	44	35	57	51	52	48	45	48	40	33	53	44						
		4	53	47	44	37	34	31	22	22	41	32	60	54	49	45	41	37	31	26	47	38	65	58	53	49	49	47	43	36	54	45						
		7	59	56	48	39	35	32	25	21	45	36	66	59	52	45	42	39	35	33	50	41	74	67	60	53	52	47	44	41	58	49						
		10	62	59	49	40	35	30	28	26	47	37	72	64	55	47	42	39	34	33	53	44	78	72	63	54	52	47	44	43	61	52						
800	400	1	48	43	40	36	39	29	16	14	41	32	47	47	47	39	43	41	27	21	47	38	53	51	53	50	46	48	41	35	53	44						
		2	50	46	46	40	37	31	18	16	43	34	53	50	46	45	45	40	28	24	48	39	58	55	57	52	50	53	39	34	57	48						
		4	50	50	49	41	37	32	23	30	44	35	59	56	52	49	45	39	30	26	50	42	65	60	55	51	54	52	44	36	58	49						
		7	60	57	51	43	39	35	29	23	47	38	66	62	54	48	45	41	36	35	52	43	75	68	61	56	56	50	45	43	61	52						
		10	66	65	54	43	39	34	32	34	52	43	71	67	58	50	47	41	36	36	55	47	79	74	64	55	55	50	46	44	62	54						

Conversion to other model sizes is realised at the same throttle point of air speed and pressure loss using the ΔL values from the following chart. The values are applicable to the associated unit height H.

$$L_{W \text{ Okt}} = L_{W \text{ Chart}} + \Delta L$$

$$L_{WA} = L_{WA \text{ Chart}} + \Delta L$$

Δp_{tot}	- Total pressure difference	Width B	Height H [mm]					
		[mm]	100	150	200	250	300	400
f_m	- Octave mid band frequency	200	-2		-5			
		300	0	-1	-3	-3	-3	
L_W	- Sound power level	400	1	0	-2	-2	-2	-3
L_{WA}	- Sound power level, A-weighted	500	2	1	-1	-1	-1	-2
		600	3	2	0	0	0	-1
L_{pA}	- Sound pressure level, A-weighted	800			1	1	1	0
		1000				2	2	1
		1200					3	2

Controller and air duct with insulating case
Reverberation room

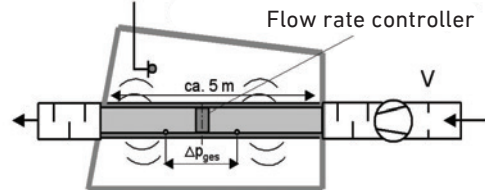

Technical brochure • Variable flow rate controllers VRActive, square

Room sound pressure level calculation from controller sound transmission (excluding flow noise from the air diffusers)

Insertion sound attenuation for the splitter attenuator type SDF-SM (optional, included in chart on page 8)

f_m	[Hz]	63	125	250	500	1000	2000	4000	8000
$\Delta L_{W \text{ Okt}}$	[dB/Okt]	2	4	8	17	33	32	18	14

System attenuation according to VDI 2081

f_m	[Hz]	63	125	250	500	1000	2000	4000	8000
Deflection $\Delta L_{W \text{ Okt}}$	[dB/Okt]	0	0	1	2	3	3	3	3
Room attenuation $\Delta L_{W \text{ Okt}}$	[dB/Okt]	5	5	5	5	5	5	5	5
Outlet reflection $\Delta L_{W \text{ Okt}}$	[dB/Okt]	10	5	2	0	0	0	0	0

Branching attenuation for distributing the sound power over multiple rooms, $V_{\text{room}} = 540 \text{ m}^3/\text{h}$

f_m	$[\text{m}^3/\text{h}]$	540	1080	2160	5400	10800	16200	21600
$\Delta L_{W \text{ Okt}} = 10 \times L_g \frac{V}{540 \text{ m}^3/\text{h}}$	[dB/Okt]	0	3	6	10	13	14	16

Sample calculation sound transmission

Given: VRActive 500 x 200 with sound absorber type SDF-SM

$V_{\text{max}} = 1440 \text{ m}^3/\text{h}$, equates to 4 m/s

$\Delta p_{\text{tot}} = 200 \text{ Pa}$

Required: Room sound pressure level L_{pA} from controller sound transmission

Solution:	f_m	[Hz]	63	125	250	500	1000	2000	4000	8000	Source
Sound power level size 600 x 200	$L_{W \text{ Okt}}$	[dB/Okt]	62	54	51	44	26	28	39	38	page 8
Converted to size 500 x 200	$\Delta L_{W \text{ Okt}}$	[dB/Okt]	- 1	- 1	- 1	- 1	- 1	- 1	- 1	- 1	page 8
Deflection	$\Delta L_{W \text{ Okt}}$	[dB/Okt]	0	0	- 1	- 2	- 3	- 3	- 3	- 3	page 11
Room attenuation	$\Delta L_{W \text{ Okt}}$	[dB/Okt]	- 5	- 5	- 5	- 5	- 5	- 5	- 5	- 5	page 11
Outlet reflection	$\Delta L_{W \text{ Okt}}$	[dB/Okt]	- 10	- 5	- 2	0	0	0	0	0	page 11
Branching attenuation	$\Delta L_{W \text{ Okt}} = 10 \times L_g \frac{1440 \text{ m}^3/\text{h}}{540 \text{ m}^3/\text{h}}$	[dB/Okt]	- 4	- 4	- 4	- 4	- 4	- 4	- 4	- 4	page 11
A-weighted	$\Delta L_{W \text{ Okt}}$	[dB/Okt]	- 26	- 16	- 9	- 3	0	1	1	- 1	
A-weighted sound pressure level	$L_{pA \text{ Okt}}$	[dB(A)/Okt]	16	23	29	29	13	16	27	24	

A-weighted sum sound pressure level $L_{pA} = 34 \text{ dB(A)}$

Technical brochure • Variable flow rate controllers VRActive, square

Room sound pressure level calculation from controller radiation

f_m	[Hz]	63	125	250	500	1000	2000	4000	8000
Ceiling attenuation $\Delta L_{W Okt}$	[dB/Okt]	4	4	4	4	4	4	4	4
Room attenuation $\Delta L_{W Okt}$	[dB/Okt]	5	5	5	5	5	5	5	5

Sample calculation radiation

Given: VRActive 500 x 200 with insulation case

$V_{max} = 1440 \text{ m}^3/\text{h}$, equates to 4 m/s

$\Delta p_{tot} = 200 \text{ Pa}$

Required: Room sound pressure level L_{pA} from controller radiation

Solution:	f_m	[Hz]	63	125	250	500	1000	2000	4000	8000	Source
	Sound pressure level size 600 x 200 $L_{W Okt}$	[dB/Okt]	60	53	48	41	37	36	32	26	page 10
	Converted to size 500 x 200 $\Delta L_{W Okt}$	[dB/Okt]	- 1	- 1	- 1	- 1	- 1	- 1	- 1	- 1	page 10
	Ceiling attenuation $\Delta L_{W Okt}$	[dB/Okt]	- 4	- 4	- 4	- 4	- 4	- 4	- 4	- 4	page 12
	Room attenuation $\Delta L_{W Okt}$	[dB/Okt]	- 5	- 5	- 5	- 5	- 5	- 5	- 5	- 5	page 12
	A-weighted $\Delta L_{W Okt}$	[dB/Okt]	- 26	- 16	- 9	- 3	- 0	1	1	- 1	
	A-weighted sound pressure level $L_{pA Okt}$	[dB(A)/Okt]	16	23	29	29	13	16	27	24	

A-weighted sum sound pressure level $L_{pA} = 35 \text{ dB(A)}$

Technical brochure • Variable flow rate controllers VRActive, square

Nomenclature, ordering code

VRActive / ... x ... / S / D / B 681
(1) (2) (3) (4) (5) (6) (7)

(1) Type	VRActive	=	Flow rate controller, rectangular, short, with map control
(2) Measuring principle		=	dynamic
	S	=	static
(3) Dimensions	... x ...	=	width x height [mm] (see page 6)
(4) Version	S	=	galvanised steel
	K	=	coated
(5) Insulating case	D	=	with insulating case
	-	=	without insulating case
(6) Compact controller (make)	B	=	Belimo
	G	=	Gruner
(7) Compact controller (type)	681	=	Belimo LMV-D3W-E-MF (standard up to nominal height 250 mm)
	680	=	Belimo LMV-D3W-E-MP (compatible with MP-Bus, up to nominal height 250 mm)
	690	=	Belimo NMV-D3W-E-MP (compatible with MP-Bus, standard from nominal height 300 mm)
	672	=	Belimo LMV-D3W-MOD-F (compatible with Modbus and BACnet, up to nominal height 250 mm)
	692	=	Belimo NMV-D3W-E-MOD (compatible with Modbus and BACnet, from nominal height 300 mm)
	227-05	=	Gruner 227VM-05 (static, up to nominal height 250 mm)
	227-10	=	Gruner 227VM-10 (static, from nominal height 300 mm)

Additional order informations

Please specify when ordering

- V_{\min} [m³/h]
- V_{\max} [m³/h]
- Mode:
0...10 V or 2...10 V

Please notice:

- V_{nom} see page 7
- $V_{\min} \geq 0 \text{ m}^3/\text{h}$
- $V_{\min} \leq V_{\max}$
- $V_{\max} \leq V_{\text{nom}}$
- $V_{\max} \geq 0,2 V_{\text{nom}}$

In the absence of such specifications the unit will be delivered with the following factory settings:









- $V_{\min} = 0 \text{ m}^3/\text{h}$
- $V_{\max} = V_{\text{nom}}$
- Mode = 0...10 V

Ordering example

VRActive 600x200/S/D/B681, $V_{\min} = 1000 \text{ m}^3/\text{h}$, $V_{\max} = 3000 \text{ m}^3/\text{h}$, Mode 2...10 V

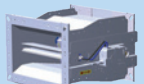
Product Overview • LTG Air Distribution

Flow rate controllers

		Round		Square		
Variable		VREactive	LTG Map Control System <i>ActiveControl</i> ; highest precision, short installation length		VRFactive	LTG Map Control System <i>ActiveControl</i> ; highest precision, short installation length
		VRDactive			VRFvent	
		VRE	To combine with customized drives; VRE also available in PPs			
		VRD				
Constant		VRW	Without external power supply, pollution-insentitive		VRX	Without external power supply, pollution-insentitive
		VRZ				

All variable controllers are available with dynamic or static measuring principle

Pressure controllers

	Round		Square		
	DRE DREactive	To balance extreme pressure level differences; optionally with flow rate measuring		DRF DRFactive	To balance extreme pressure level differences; optionally with flow rate measuring

Shut-off units

	Round		Square		
	KLB	Ultra-tight shut-off damper		ARF	Air-tight shut-off damper
	ARE	Air-tight shut-off damper			

Air-tight shut-off acc. to DIN EN 175; up to Class 4

Engineering Services



LTG Engineering Services Comfort Air Technology

Portfolio

For our complete portfolio of air distribution products with suitable accessories see <https://www.ltg.de/en/products-services/ltg-comfort-air-technology/air-distribution/>



**AIR TECH
SYSTEMS**

Comfort Air Technology

Air-Water Systems
Air Diffusers
Air Distribution

Process Air Technology

Fans
Filtration Technology
HumidificationTechnology

Engineering Services

Laboratory Test & Experiment
Field Measurement & Optimisation
Simulation & Expertise
R&D & Start-up

LTG Aktiengesellschaft

Grenzstrasse 7
70435 Stuttgart
Germany
Tel.: +49 711 8201-0
Fax: +49 711 8201-720
E-Mail: info@LTG.net
www.LTG.net

LTG Incorporated

105 Corporate Drive, Suite E
Spartanburg, SC 29303
USA
Tel.: +1 864 599-6340
Fax: +1 864 599-6344
E-Mail: info@LTG-INC.net
www.LTG-INC.net