

Translation of Original Installation/Operation/Maintenance Instructions LTG Air-Water Systems

LTG Decentral

Decentralised ventilation units
FVP *pulse*-B



Installation in false floors

Content

Content	Page	Content	Page
0 Declaration of conformity	3	5 Installation	17
1 Safety instructions	4	5.1 Installation instructions	17
1.1 Explanation of symbols and hints	4	5.2 Unit installation	17
1.2 Operating safety instructions	5	5.3 Facade outside air connection	18
2 Transport, storage, delivery	6	5.4 Water connections	19
2.1 Transport instructions	6	5.4.1 Instructions for installation of water connections using flexible hoses	22
2.2 Storage	6	5.5 Condensing operation	24
2.3 Delivery	6	5.6 Electrical connection	24
3 Function	7	5.6.1 Fault message	24
3.1 Intended use	9	5.6.2 ECO control	25
3.2 Specifications	9	5.6.3 PREMIUM control	26
3.3 Ventilation concepts	9	5.6.4 Electrical specifications of the plug-in connection	27
3.3.1 Demand-controlled ventilation	9	5.6.5 Wiring	27
3.3.2 Hybrid ventilation	9	5.6.6 Error output	27
3.3.3 Night-time ventilation	9	5.6.7 Interface	27
3.3.4 Minimum air quantity	9	5.7 Check after installation	28
3.4 Control	10	6 First use	29
3.4.1 Room temperature control	10	6.1 Emergency closing function	29
3.4.2 Wind pressure control	10	6.2 Selecting the outside air flow rate	29
3.4.3 Supply air flow rate	10	6.3 Programming instruction	31
3.4.4 Frost protection	10	6.3.1 TeraTerm operating interface	31
3.4.5 Discharge temperature limit	10	6.3.2 Parameter programming	34
3.4.6 Master-slave combinations	11	6.3.3 Software programming	34
3.4.7 Controlling the cycle time	11	7 Operation, maintenance, repair	35
3.4.8 Start-up circuit	11	7.1 Repair	35
4 Technical data	12	7.1.1 Filter change in the exhaust air filter	35
4.1 Dimensions	12	7.1.2 Filter change in the outside air filter	36
4.2 Technical data 4-pipe system	13	7.2 Maintenance	37
4.2.1 Example configurations	14	8 Spare parts, accessories	39
4.3 Electrical data	16	9 Decommissioning, disposal	39
4.4 Temperature ranges	16	10 Annexe	40
4.5 Weight	16	10.1 Component maintenance schedule / maintenance protocol	40
4.6 Acoustic data	16		
4.7 Caloric output data	16		
4.8 Hydraulic data	16		
4.9 Load-bearing capacity	16		

Notes

Dimensions stated in this brochure are in mm.

Dimensions stated in this brochure are subject to General Tolerances according to DIN ISO 2768-vL. For the outlet grille special tolerances stated in the drawing apply.

Straightness and twist tolerances for extruded aluminum profiles according to DIN EN 12020-2.

EC Declaration of conformity



0. EC Declaration of conformity



EC declaration of conformity

As defined by the EC Council Directive on Machinery 2006/42/EG, Annex II, Nr. 1A

We herewith declare that the machine described in the following conforms to all relevant provisions of the EC Machinery Directive 2006/42/EC.

Manufacturer: **LTG Aktiengesellschaft
Grenzstr. 7, 70435 Stuttgart, Germany**

Designation of machinery: **Decentralised Ventilation**

Machinery type: **FVPpulse**

Relevant EC Council Directives: **Machinery Directive (2006/42/EC)
EMC Directive (2004/108/EC)
Low Voltage Directive (2006/95/EC)**

Applied harmonized standards, in particular: **DIN EN ISO 13857, DIN EN 349, DIN EN ISO 12100, DIN EN 60335-2-40**

Other standards: **EN 61000-6-2, EN 61000-6-3; EN 60335-1, EN 50121-3-2**

Stuttgart, 08.03.2016

Signature of manufacturer

Position of signatory:  **Wagner**  **ppa. Dehlwes**

Innovative Solutions for Humans and Products.

LTG Aktiengesellschaft
Grenzstrasse 7, 70435 Stuttgart
Germany

Tel. +49 711 8201-0
Fax: +49 711 8201-720
info@LTG.de
www.LTG.de

Executive board:
Dipl.-Ing. Wolf Hartmann (chairman)
Dipl.-Ing. Ralf Wagner

Chairman of the supervisory board:
Dr. Franz Wimpffen

USt-IdNr. / VAT Reg No.
DE 812753932

Trade register:
district court Stuttgart.
No. HRB 20451
Place of performance / court of
jurisdiction Stuttgart

Bank details:
Landesbank Baden-Württemberg, Stuttgart
IBAN: DE34 6905 0101 0002 5756 67
SWIFT-BIC: SOLADE33600

Commerzbank AG, Stuttgart
IBAN: DE44 6904 0071 0755 0031 00
SWIFT-BIC: COBADE33XXX

1. Safety instructions

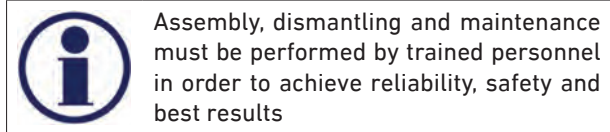

1.1 Explanation of symbols and hints

Operating safety symbol

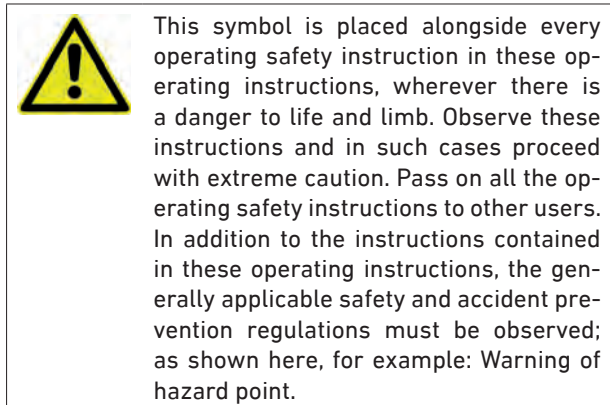

Information symbol

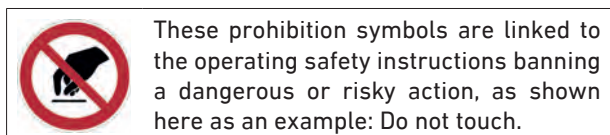
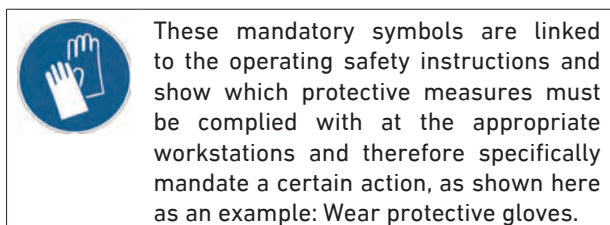
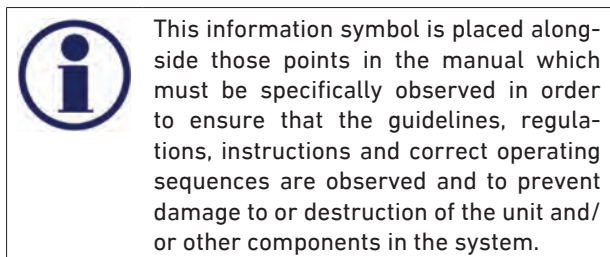

Safety

1.2 Operating safety instructions

Carefully read the safety instructions before using any LTG decentralised ventilation unit FVPpulse-B. Always follow the safety instructions!

The decentralised ventilation units FVPpulse-B meet any pertinent safety standards.



The installation and maintenance of air conditioning units may be dangerous because of high pressures and electrical components being live. Therefore, the installation, maintenance, and repair must be performed by qualified and trained staff only.

In particular, electrical connections are to be provided, removed, or modified by authorised persons only observing all relevant safety instructions.

Safety instructions in the technical documentation and on unit labels must be followed at all times.

Do not open the unit for cleaning, maintenance, or repair and do not remove covers and casings (air diffuser) unless all conducting lines have been completely disconnected. Do not connect or remove the plug-in connector when under tension.

Any work regarding the electrical equipment is to be performed by skilled and trained staff only. Connections to the main power supply and the safety earth terminal must be executed exactly as described in the wiring diagram.

Electrical operation of the unit in a partly disassembled condition or of individual components is not permitted since earth terminals might be interrupted.





During continuous operation the motor may reach temperatures of up to +65 °C. If necessary, allow the motor to cool off or wear gloves.







In the heating mode a temperature of up to 80 °C may be reached. Water-carrying parts may be hot, so do not touch with your bare hands to avoid burns.







Be careful when performing work on the heat exchangers. Blades and housing parts are sharp-edged. Wear gloves during work and handling.





The standard version of the heat exchangers is designed for an operating pressure of 10 bar (test pressure 16 bar). High water pressures may be hazardous. Higher operating pressures, therefore, require LTG's express permission. Wear safety glasses.





Be careful when working overhead and provide protection against parts falling from above.



The floor grille also serves as a protection and should be removed for maintenance and cleaning only.

Avoid any additional load to the unit or the suspensions since stability might be insufficient.

The unit must be checked by an expert immediately

- if it has been mechanically damaged
- if it is suffering from a water damage,
- if the fan shows signs of damage (imbalance, damage to the bearing or motor),
- if the suspension or the casing show clear signs of corrosion or ageing.

Do not put the unit back into operation before all necessary maintenance and repair has been performed!

Take the unit entirely off the main power supply until all repairs have been completed even if this might result in not being able to operate undamaged units.

It is in any case imperative to take a damaged unit completely off the main power supply!



Use the operating panel to disconnect the unit before starting any maintenance or repair work!

Disconnect the unit from the main power supply in all poles before opening the ventilation module!

Transport, storage

2. Transport, storage, delivery

The unit requires dry and dust-free conditions during transport, storage, installation, and operation.

Units are stacked on Euro or single trip pallets and secured with straps. Pallets may be moved using forklifts or cranes.

Do not remove the packaging until immediately prior to installation on site to protect the unit from pollution and damage.

The packaging is not weather-resistant.

The packaging is disposable and is not to be returned to LTG Aktiengesellschaft.

Disposal of the packaging material in accordance with local regulations.



The protective board (chipboard) serves to protect the unit from dust and damage. Do not remove it during construction!

LTG Aktiengesellschaft will not take responsibility for any pollution of or damage to the unit.

If removal of the protective board - e.g. for fitting or checking of the flexible water connection hoses - is indispensable, it must be put back into its original position (clean side downwards) immediately after the work is completed. Care must be taken here that no dirt can get into the unit either when the protective board is lifted off/replaced or during work on the unit.

Do not replace the protective board with the grille unless any pollution of or damage to the unit is ruled out, i.e. all subsequent work or activities in the unit's vicinity have been completed.

2.1 Transport instructions

Handle units appropriately and with care during transport.

Do not throw them, let them drop to the ground or bump them into other items or walls.

Make sure that units are safely fastened during transport and avoid damage caused by other items.

With manual transport, the individual units should be moved by 4 persons min.

2.2 Storage

Make sure that units are entirely protected against weathering, humidity and other adverse conditions that might result in damage during storage.

The storage location must meet the following climatic requirements:

Temperature between -20 °C and +70 °C with a relative humidity of 90 % max. (non-condensing).

2.3 Delivery

Standard units are normally delivered as follows:

- 2...3 units on Euro disposable pallet, pallet shrink-wrapped
- Fitting/control accessories packaged with them in separate boxes

Function

3. Function

The FVP*pulse*-B is a decentralised 4-pipe ventilation unit for installation in false floors that is used to ventilate and extract air from occupied areas directly via the facade. It is also used to heat and cool the outside air and offers a highly efficient heat recovery system.

This decentralised ventilation unit is the ideal choice for areas in which high air quality and thermal comfort are important criteria.

Breathing IN in winter (air supply mode)

Function: The heat recovery unit is still warm from the outlet cycle. The Breathing IN cycle now starts:

1. The outside air is drawn in through the facade opening and supply air filter.
2. The outside air flows through the heat recovery unit and is heated.
3. The air passes through the fan's inlet chamber (lower level).
4. The EC fan transports the air from the inlet chamber (lower level) into the pressure chamber (upper level).
5. In the upper level, the supply air passes through the silencer. Here, it passes through the damper and into the supply air duct.
6. After leaving the supply air duct, the air is cooled or heated by the heat exchanger and is discharged out through a supply air grille.

The flow is reversed by switching over the damper.

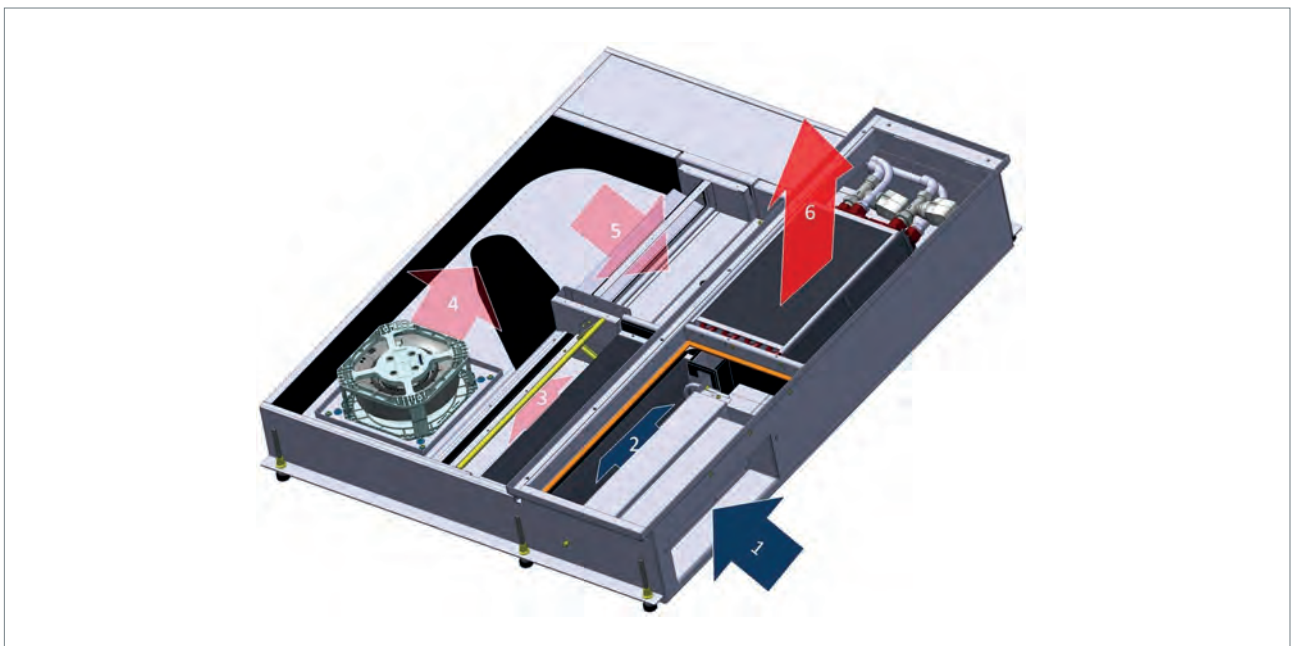

Breathing IN (air supply mode)

Function

Continuation 3. Function

Breathing OUT in winter (exhaust air operation)

- 1 The exhaust air is drawn out of the room via the heat exchanger bypass and the "exhaust (waste) air filter".
2. The air passes through the damper and into the suction chamber (lower level).
- 3 In the suction chamber, the air flows to the EC fan (lower level).
4. The EC fan transports the air from the suction chamber (lower level) into the pressure chamber (upper level).
- 5 The warm air flows through the damper to the heat recovery unit where its energy is transferred to this unit.
6. The exhaust air is now evacuated to the outside via the facade opening.

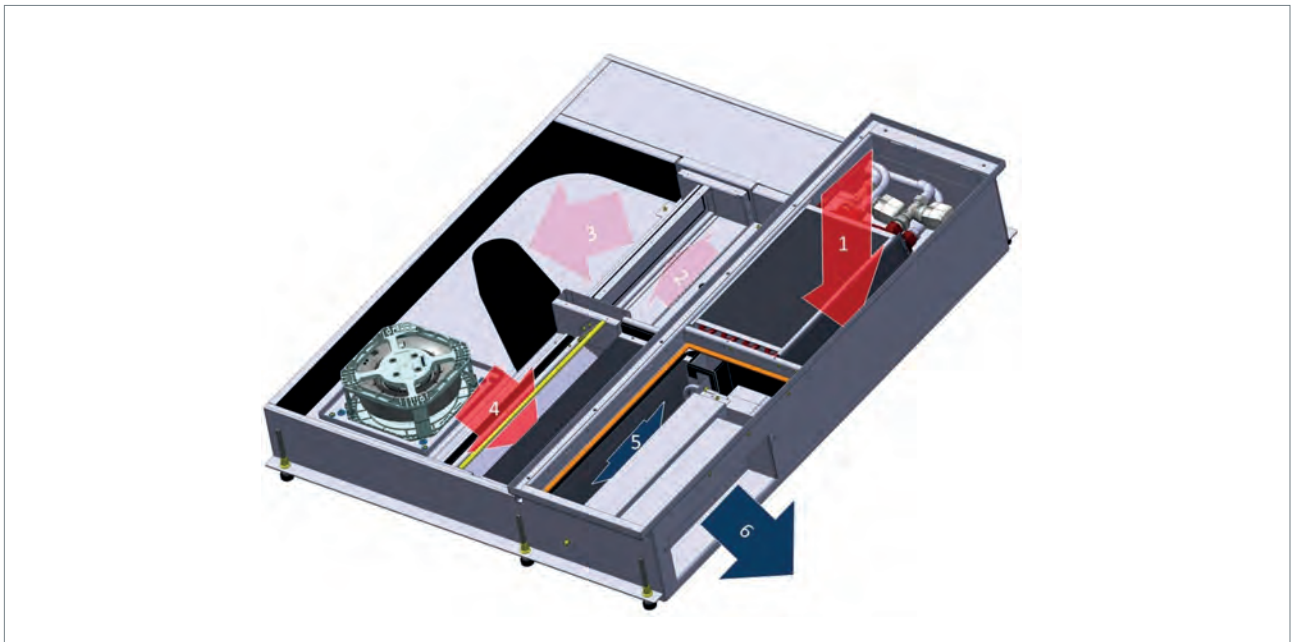

Breathing OUT (exhaust air operation)

Function

3.1 Intended use

Use	Interiors
Ambient conditions during installation	
Temperature	max. +40 °C
Inlet temp.	max. +80 °C
rel. humidity	max. 90 % (no condensation forming)
Ambient conditions during operation	
Temperature	+5...+40 °C
rel. humidity	max. 90 % (no condensation forming)



Any other operating conditions require the express and written permission of LTG Aktiengesellschaft. LTG Aktiengesellschaft does not assume responsibility for any damages resulting from unintended use.

3.2 Specifications

All components comply with VDI 6022.

Housing, manufactured from galvanised sheet steel, black coating in visible area. With punched openings for water pipes and electrical connections.

Heat exchanger, manufactured from a corrosion-resistant aluminium alloy (EN AW 8006). Water-side connection G ½" female thread. Permitted water-side working pressure: 12 bar, 4-pipe system.

Heat recovery unit

Highly efficient class H1 regenerator as per DIN EN 13053. The lamellae are manufactured from a corrosion-resistant aluminium alloy (EN AW 8006). The unit cannot freeze up during its cyclical mode of operation because the surface temperature of the regenerator fluctuates periodically about a mean value. Heat recovery levels of up to 90 % depending on the cycle time. Air filter for outside and exhaust air.

The ventilation unit is equipped with an **outside air filter** (comparable to filter class F7) with information plate indicating the filter type, inspection interval and time of last filter replacement, as well as with an exhaust air filter (comparable to G2).

Fan

Low-noise radial fan with energy-saving, highly efficient EC motor (SFP class 1, < 500 W/m³/s)

Facade-mounted damper / Internal sealing of the unit

In the event of a power failure, the facade-mounted damper is closed automatically (VDMA 24390) thanks to an actuating drive equipped with capacitors. Leakage air flow (relative to circumference of damper): Class 3

Acoustic and thermal insulation

The silencers are made from low-flammability insulating materials (B1) with a closed-pore cover layer. They are rot-proof and resistant to the formation of mould or mildew.

Condensate

The alternating air flow prevents condensation in the heat recovery unit. In the case of cooling, non-condensation-forming operation of the heat exchanger must be assured.

3.3 Ventilation concepts

3.3.1 Demand-controlled ventilation

A CO₂ switch, presence or movement sensor registers the ventilation requirement.

1st possibility: One unit per room

The transient ventilation system causes pressure fluctuations in the room. These pressure fluctuations can be balanced out using soundproofed overflow ports (supplied by LTG). This also permits the decentralised ventilation of indoor areas.

2nd possibility: Two units per room

If two units are installed in each room then an overflow port is no longer required. The units can be connected together within a "master-slave configuration" in such a way that one unit draws air into the room while the other unit evacuates it again. In this configuration, one master unit is connected to at most one slave unit. Because the units operate cyclically in alternation, no over-pressure or under-pressure occurs in the room.

3.3.2 Hybrid ventilation

It is possible to pass 240 m³/h of clean supplied air through the unit. Hybrid ventilation is used to respond to the needs of peak cooling loads in the summer. When hybrid ventilation is used, the unit acts as a simple supply air unit. The exhaust air can be evacuated through a window left ajar, for example. This almost doubles the cooling capacity of the unit as well as the fresh air volume without increasing noise emissions.

3.3.3 Night-time ventilation

In night-time ventilation, the units are switched to a stationary operating mode. The units must be controlled in such a way that one unit takes air in while the unit opposite is evacuating air (in the case of master-slave communication, it is not necessary to control the slave unit separately). In this way, the building can be ventilated and cooled on cool summer nights without having to leave any windows open. The heat recovery function is therefore not active.

3.3.4 Minimum air quantity

To minimise the energy costs in the building, the outside air quantity should be adapted to the requirements of the personnel in the associated office unit.

Function

3.4. Control

To incorporate a decentralised ventilation unit FVP-pulse-B into a control circuit, the following special factors have to be taken into account:

The heat exchanger has outside air flowing through it. It can be regulated by a simple room temperature controller. However, it may be that further parameter adjustments are needed there (see for example start-up circuit).

The parameters should be set such that ventilation takes place even if neither heating nor cooling does (dead zone deactivation).

3.4.1 Room temperature control

Control of the room temperature must be achieved with a suitable cascade such that the desired room temperature is adjusted in the frequented zone. To do so, steady valve drives are recommended in all cases.

To ensure a steady control response by valves, unit and MSR, i.e. permitting a constant supply air temperature, a guide for the hot water inlet temperature to match the outside air temperature must be provided.

3.4.2 Wind pressure control

(with Premium control)

Maintaining the required outside air flow rates as a function of the wind pressures impinging on the intake opening is handled by a control system. External access to this control system is not possible.

If there is any positive or negative pressure applied to the facade, the conveyed supply air and exhaust air flow rates are adjusted accordingly by asynchronous control of the supply air and exhaust air conveying respectively.

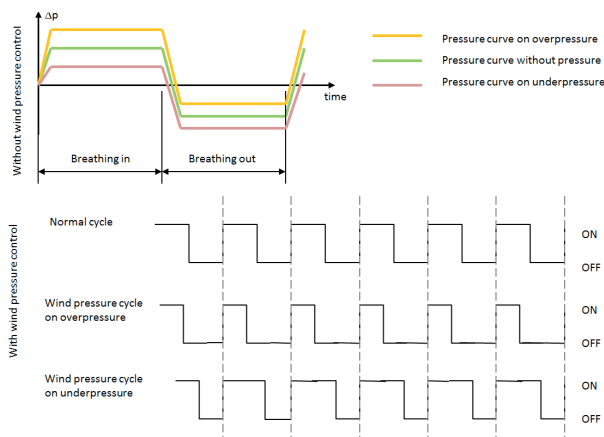

3.4.3 Supply air flow rate

ECO control

Three "flow rate stages" to be connected match the customer-specified set flow rates, (e.g. 60 m³/h - 90 m³/h - 120 m³/h).

Premium control

The flow rate can be actuated steadily by a 1...10 V signal. If a control voltage of <1 V is emitted (Premium control) or if no flow rate stage is actuated (ECO control), then the unit closes the outside air flap and the fan comes to a stop.

If the unit does not have the set voltage, the outside air flap closes.

3.4.4 Frost protection

Since the heat exchanger in decentralised ventilation units has at least a proportionate outside air quantity flowing through it, there is a risk in the event of failure of the hot water supply (caused for example by a failure of the valve drive) of the heat exchanger freezing up.

This failure can be registered by monitoring the discharge temperature before a defect in the heat exchanger. A frost protection switch monitoring the discharge temperature switches off the fan when a limit temperature of, for example, +10°C is exceeded (standard value, but freely parameterisable) and closes the outside air flap.

This operating point should, when the unit and the control system are functioning, not normally occur in the case of either heating or cooling.

The frost protection sensor does not protect against a simultaneous failure of the control system. Maximum safety is achieved when a frost protection monitor with capillary tube sensor is used as a redundant system.

If the temperature is exceeded at the sensor by, for example, +13 C (standard value, but freely parameterisable), the unit switches back on automatically and tries to resume normal operation.

3.4.5 Discharge temperature limit

To optimise the thermal comfort in the zone frequented by personnel, the discharge temperature should be monitored and limited downwards by suitable valve settings.

It should never fall below the room temperature by more than 8 Kelvin.

This however also limits the available cooling capacity.

Function

Continuation 3.4 Control

3.4.6 Master-slave combinations

If, for example, two units are installed in each room and there is no overflow port, then the "master unit" must communicate with the "slave unit". This communication takes place over a commercially available Ethernet cable. In this type of application, it is only necessary to control one unit (the master unit) as the slave unit then works in the opposite mode to the master. In this case, control inputs at the slave are not processed.

This configuration ensures that no over-pressure or under-pressure occurs in the room. The configuration (definition of the master and slave unit) is specified via the USB port.

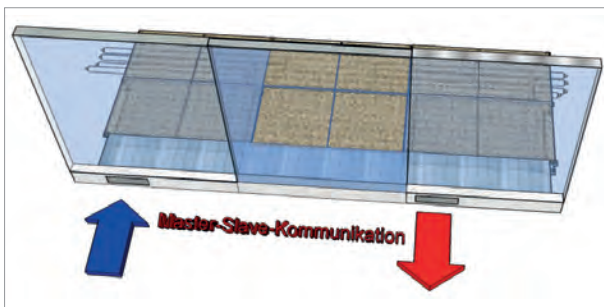

Each master unit is connected to a maximum of one slave unit



Master-slave communication in combination with the control inputs for supply air (BZ) or exhaust air (BA) can only be configured in such a way that the "slave unit" (in both operating modes) operates only in the opposite mode to the master unit (standard) or in the same mode as it. This means, for example, that hybrid ventilation and night-time ventilation using two units per room without overflow ports is not possible.

3.4.7 Controlling the cycle time

The heat recovery level of the heat recovery unit can be affected by the cycle time during breathing in/out. The shorter the cycle time, the higher the heat recovery level. This cycle time (standard value 40 s) can be parameterised via the USB port. With the Premium board a 1...10 V input signal is also available. This cycle time can be set infinitely from 10...80 s.

3.4.8 Start-up circuit

To rule out a fall in the temperature at the heat exchanger to <10 C at low outside temperatures (mixed temperature of outside air and recirculated air), the heat exchanger first has to have hot water flowing through it before the unit is started up.

Operating mode	Control without GLT	Building control system (GLT)	Input at board	Signal
Standard (cyclical operation)	Set value at master; slave in opposite mode	Set value at master; slave in opposite mode	ST 1, 2, 3 (ECO control) Constant flow rate (Premium control)	L (230 V AC 50 Hz) 1...10 V DC
Hybrid ventilation	Window contact at supply air input ("BZ") at master; slave in same mode (supply air) *	Window contact at GLT; GLT at supply air input at master ("BZ"); slave in same mode (supply air) **	Supply air mode "BZ"	L (230 V AC 50 Hz)
Night-time ventilation ***	Not recommended	Depending on installation location, signal from building control system to supply air mode ("BZ") or exhaust air mode ("BA") ***	Supply air mode ("BZ") or exhaust air mode ("BA")	L (230 V AC 50 Hz)

* In the winter, there is a risk that the heat recovery unit may freeze if the window is open.

** The building control system (GLT) should only permit hybrid ventilation in the summer because there is a risk that the heat recovery unit may freeze if the window is open in the winter.

*** If, for example, the master unit is switched to supply air mode ("BZ"), then the slave unit operates in exhaust air mode without receiving a control signal.

Function

3.5 Decentralized control LTG Connected Intelligence

Application

„Connected Intelligence“ (CI) is a control concept for decentralized control of air-water systems of LTG Aktiengesellschaft. The core piece is the individually parameterizable CI board, which is installed in each unit (decentralized ventilation unit FVPpulse, fan coil unit or induction unit). It offers the possibility to control decentralised ventilation units, fan coil units and induction units.

„Connected Intelligence“ communicates via Modbus RTU and functions as a slave field unit, but can also take over master functions. In the building, both stand-alone solutions and zone solutions with a higher-level building management system can be implemented.

Function

The CI board controls the room temperature and air quality. As input variable, it only requires information on the desired operating mode and the setpoints and actual values in the control zone. The CI board independently controls the fan, cycle time, heating and cooling valve at decentralised unit level. It communicates via Modbus RTU with other bus subscribers or higher-level instances depending on the implemented concept for the building management system (BMS).

Device, CI board and valves form a unit and are completely wired together at the factory.



Example with the decentralised ventilation unit FVPpulse-B

Technical data

4. Technical data

4.1 Dimensions

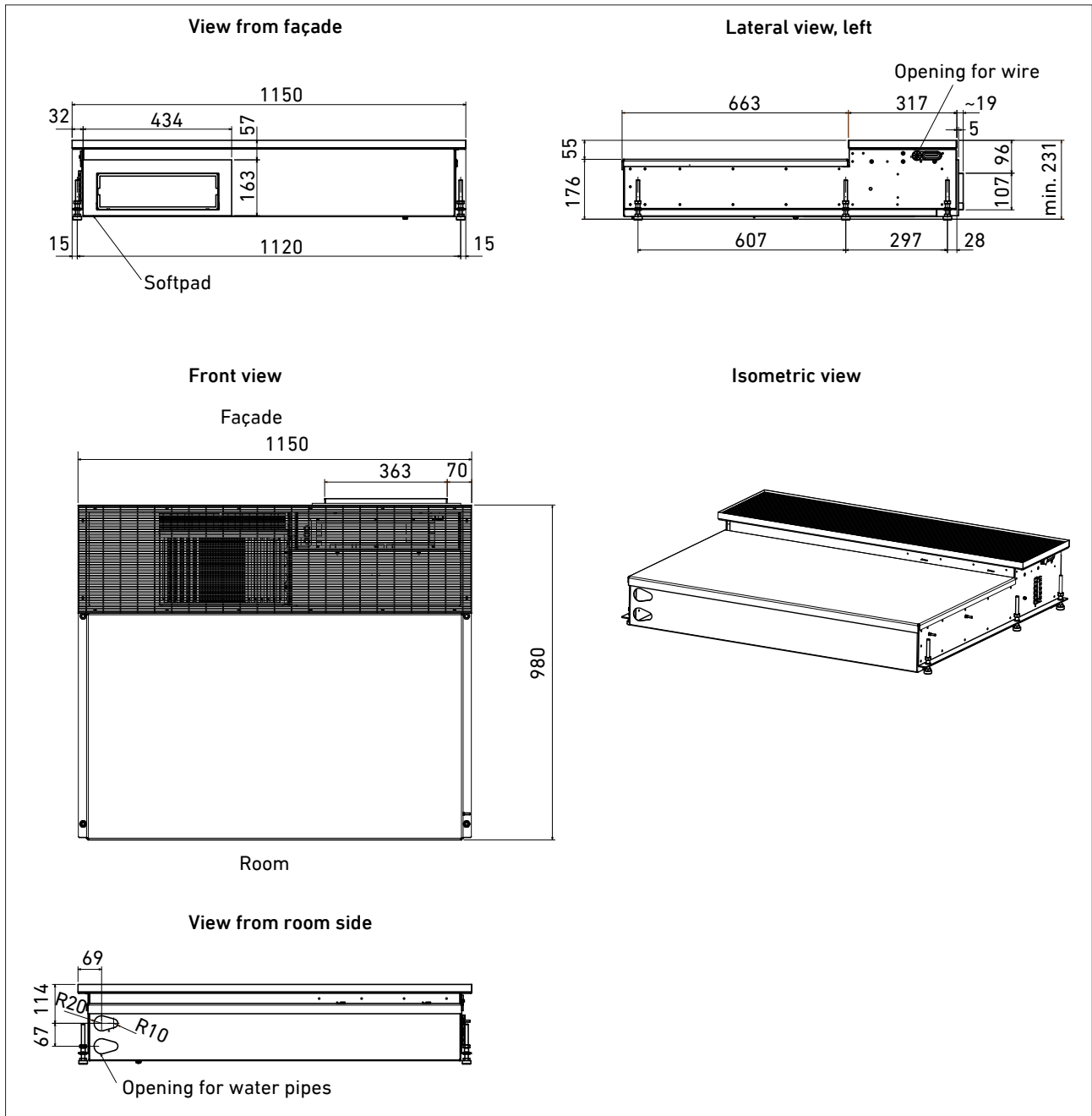

Technical data

4.2 Technical data for 4-pipe system, cycle time 2 x 20 s

P _{el} (4) [W]	L _{WA} [[dB(A)]	V [m ³ /h]	Heating				Cooling				w _{oh} [kg/h]	w _{ok} [kPa]
			Q _{H, tot} (1) [W]	Q _{H, room} (1) [W]	T _{H, ZU} (1) [°C]	T _{H, RL} (1) [°C]	Q _{K, tot} [W]	Q _{K, room} [W]	T _{K, ZU} [°C]	T _{K, RL} [°C]		
25	45	240 ³⁾	–	–	–	–	-885 ³⁾	-405 ³⁾	21 ³⁾	21 ³⁾	100 / 2	160 / 4
17	41	200 ³⁾	–	–	–	–	-796 ³⁾	-396 ³⁾	20 ³⁾	20 ³⁾		
12	37	160 ³⁾	–	–	–	–	-688 ²⁾	-370 ³⁾	19 ³⁾	20 ³⁾		
25	45	120	2167 ¹⁾	807 ¹⁾	42 ¹⁾	50 ¹⁾	-572 ²⁾	-336 ²⁾	18 ²⁾	18 ²⁾		
17	41	100	1916 ¹⁾	782 ¹⁾	46 ¹⁾	51 ¹⁾	-496 ²⁾	-296 ²⁾	17 ²⁾	18 ²⁾		
12	37	80	1633 ¹⁾	727 ¹⁾	52 ¹⁾	52 ¹⁾	-409 ²⁾	-249 ²⁾	17 ²⁾	17 ²⁾		
8	32	60	1324 ¹⁾	644 ¹⁾	54 ¹⁾	53 ¹⁾	-313 ²⁾	-193 ²⁾	16 ²⁾	17 ²⁾		

- At 60 °C water supply temperature, -12 °C outside air temperature, 22 °C room temperature, heat recovery level 76...82 %, free intake without external pressure loss
- At 16 °C water supply temperature; 32 °C outside air temperature, 26 °C room temperature, non-condensing operation, heat recovery level 78...82 % free intake without external pressure loss
- Hybrid ventilation: In the summer, the exhaust air can be evacuated via a window left ajar. In this case, the unit operates continuously in air supply mode. This almost doubles the unit's cooling capacity and the fresh air volume without causing any change to noise emissions. However, no heat recovery is possible.
- The electrical power input, including for control during ventilation operation.

P _{el}	– Electrical power input
L _{WA}	– Acoustic power level ± 3 dB(A)
V	– Flow rate
Q _{H,tot}	– Heating capacity of unit, incl. heat recovery
Q _{H,room}	– Available room heating capacity
T _{H,ZU}	– Supply air temperature in heating mode
T _{H,RL}	– Water return temperature in heating mode
Q _{K,tot}	– Cooling capacity of unit, incl. heat recovery
Q _{K,room}	– Available room cooling capacity
T _{K,ZU}	– Supply air temperature in cooling mode
T _{K,RL}	– Water return temperature in cooling mode
w _{oh}	– Nominal water volume for heating
w _{ok}	– Nominal water volume for cooling

Technical data

4.2.1 Example configurations

Due to the many different parameters that influence the capacity of a decentralised ventilation unit, it is only possible to present an example here. Other configurations can be found in the Selection Program.

Cooling capacity (top)

- Outside air flow rate 120 m³/h
- Room temperature 26 °C
- Water supply temperature 16 °C
- Nominal water volume 160 kg/h

Heating capacity (bottom)

- Outside air flow rate 120 m³/h
- Room temperature 22 °C
- Water supply temperature 60 °C
- Nominal water volume 100 kg/h

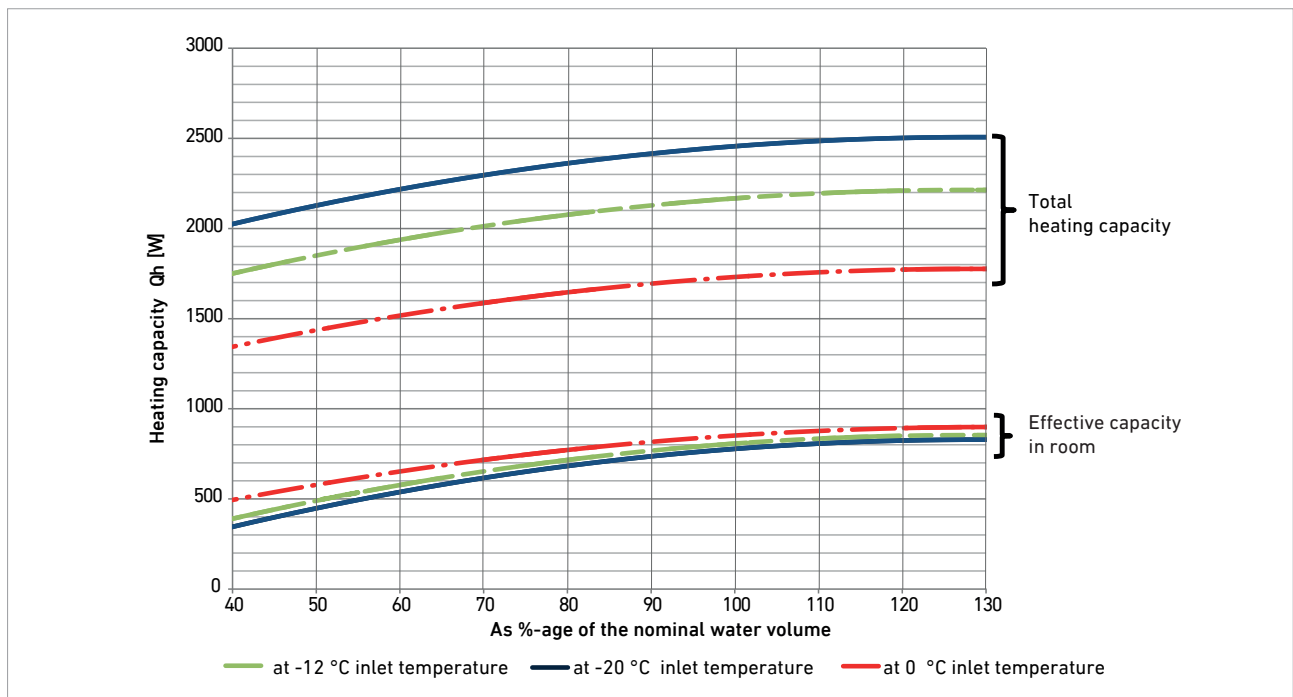
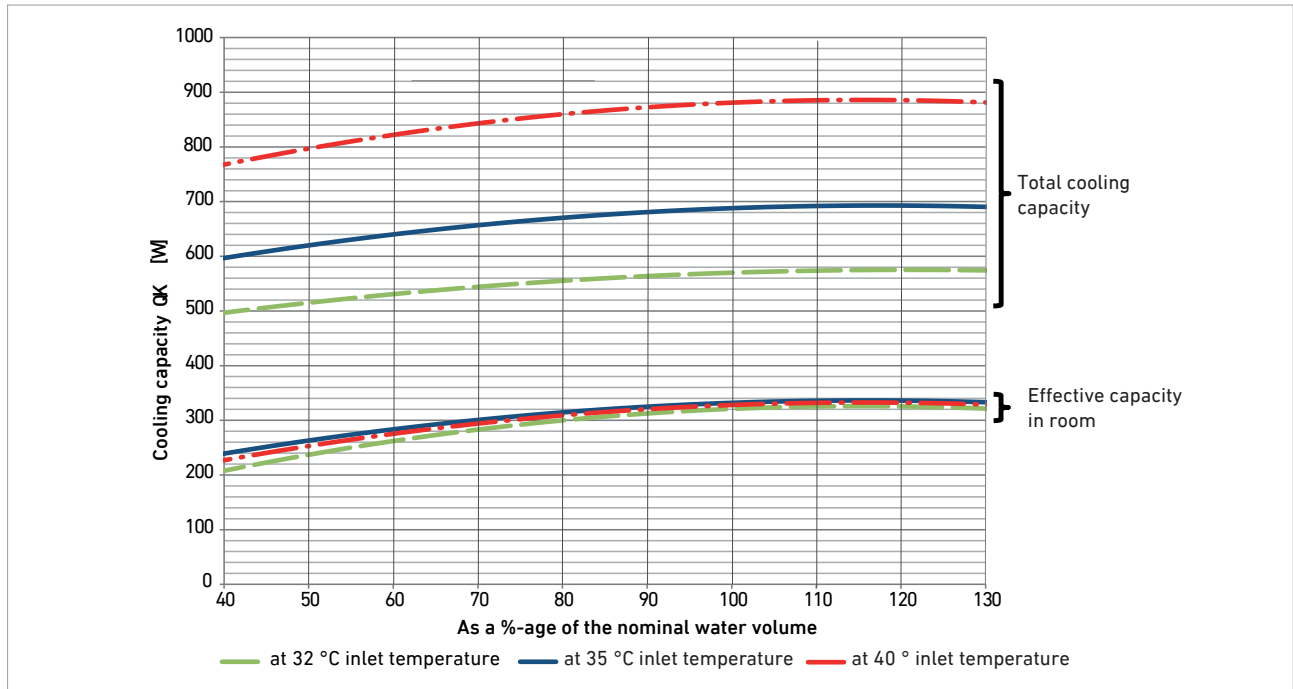

Technical data

Continuation 4.2.1 Example configurations

Water-side pressure loss of cooling/heating capacity at different water volumes

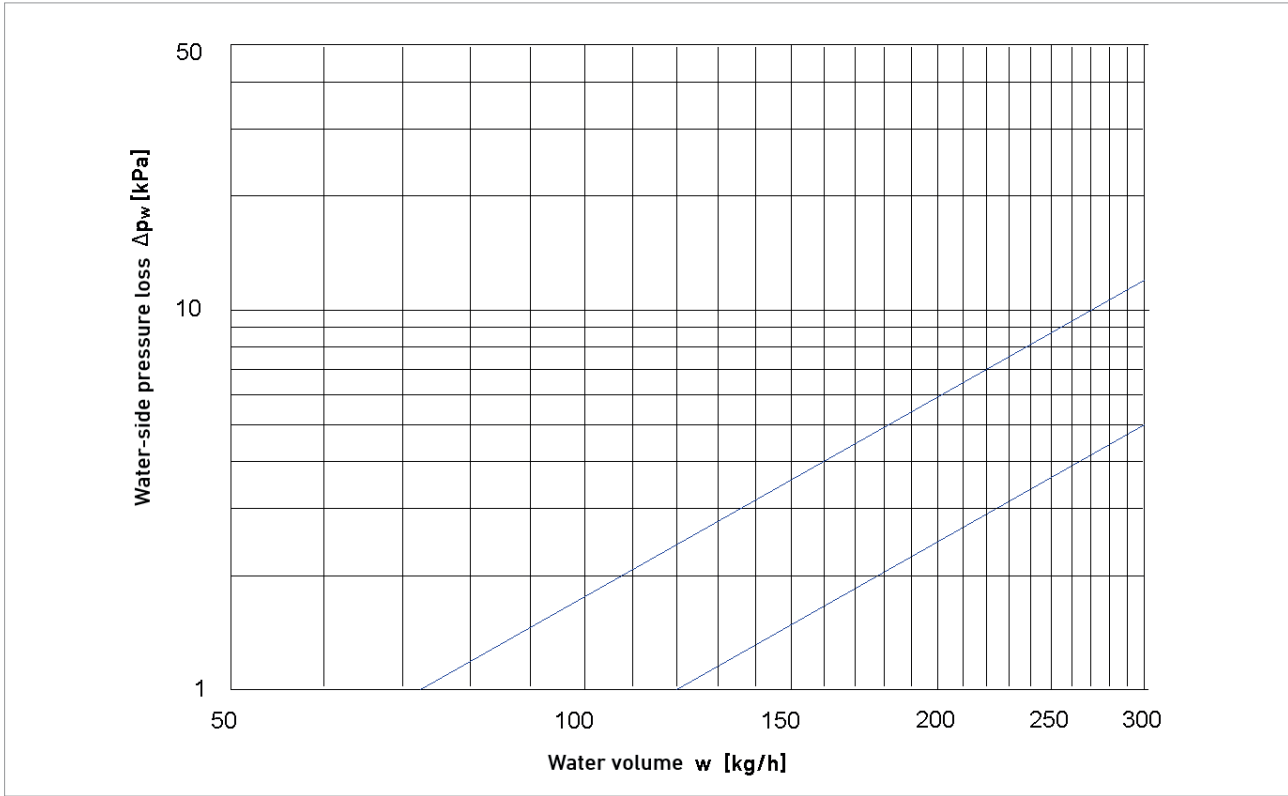

Heat recovery level as a function of cycle time

One cycle consists of:

- Supply air operation
- Switchover from supply to exhaust operation
- Exhaust operation

Standard cycle time 40 s:

- 19 seconds supply air operation
- 2 seconds switchover
- 19 seconds exhaust operation

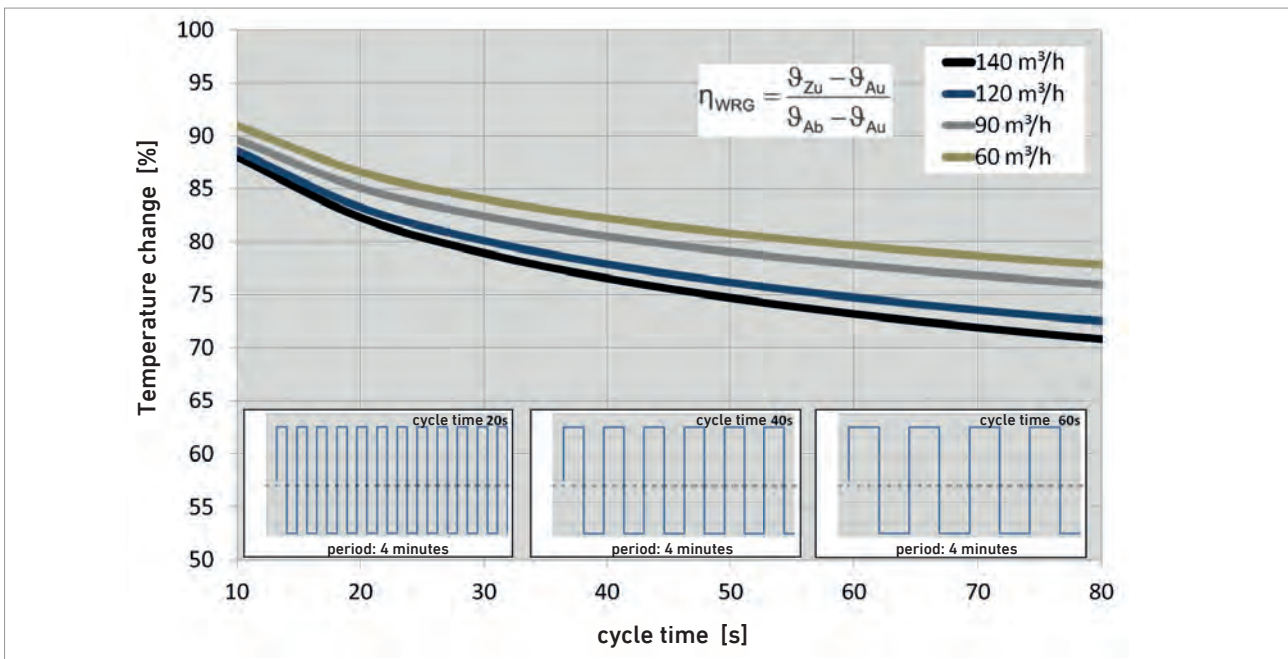

Technical data

4.3 Electrical data

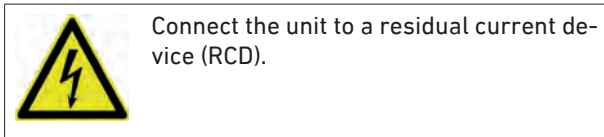

Voltage supply Control	230 V AC (+ 10...15 %) 50...60 Hz
Power consumption, control	max. 35 W
Switch outputs	230 V AC
Switching capacity of error relay	max. 2000 VA/10 A
Switching capacity of fan relay	max. 2000 VA/10 A

4.4 Temperature ranges

Storage temperature	-20...+70 °C
Operating temperature	0...+50 °C

4.5 Weight

100 kg without floor grille

4.6 Acoustic data

Acoustic data have been determined in a reverberation chamber in the LTG test lab.

The technical data sheet contain the A-weighted sound pressure levels LA_{18} for different fan speeds.

Sound pressure levels apply to a room absorption surface of 18 m² which equals a room absorption of about 6 dB(A). Thus, sound power levels may easily be calculated.

Sound pressure levels apply to a room absorption surface of 18 m² which equals a room absorption of about 6 dB(A). Thus, sound power levels may easily be calculated.

$$LWA = LA_{18} + 6 \text{ dB(A)}$$

The data given apply to one unit, i.e. one room axle. If more than one unit is installed in the same room, the sound pressure level will rise accordingly.

Increase in sound level with several sound sources of the same type:

Number of sound sources of the same type	1	2	3	4
Sound level increase [dB]		3	5	6

4.7 Caloric output data

Caloric output data were determined at a test stand in the LTG test lab.

Data are valid if the following applies:

- unit at operating temperature, steady-state condition
- steady-state condition during measurements
- no condensation at the heat exchanger in the cooling mode
- water without additives (drinking water quality) *
- water supply temperatures +12...+6 °C in the cooling mode and +50...+60 °C in the heating mode.

* To lower the freezing point, cooling water is often added some ethylene glycol. The lower specific thermal capacity of the mixture reduces the unit's cooling capacity.

Parameters used:

- specific heat capacity of the water 4186 J/(kgK)
- specific heat capacity of the air 1004 J/(kgK)
- air density 1,2 kg/m³

To ensure easy transferability, the specific caloric outputs - i.e. the absolute caloric outputs in relation to the temperature difference between water intake and induction air before entering the heat exchanger - are given with varying fan speeds..

The outputs given in the chart do apply with specific nominal water flow rates only. These are stated for each type and size.

The correction charts give a graphic illustration of how outputs change with other flow rates compared to nominal water flow rate output.

Measuring accuracy is ±10 %

4.8 Hydraulic data

- Heat exchangers are approved for an operating pressure of 10 bar max. (test pressure 16 bar). Pressures exceeding 10 bar require a separate agreement.
- Water-side pressure losses have been measured directly at the heat exchanger connections. Further resistances will have to be added.

Measuring accuracy is ±10 %.

4.9 Load-bearing capacity

The ventilation unit can be subjected, in the area of the floor plates, to a surface load of 1500 kg/m².

Installation

5.0 Installation

5.1 Installation instructions

The unit is usually supplied as described in the following:

- Unit with completely retracted feet and slightly fixed counternuts and a protective board (chipboard) inserted instead of the foot traffic resistant grille.
- Required installation material and parts, if any, such as rivets, screws, bolts, junction sheets, fixing links, air duct are included in the delivery.

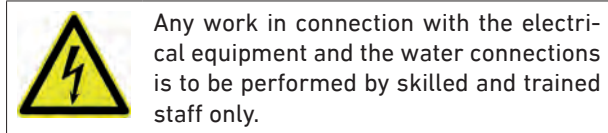
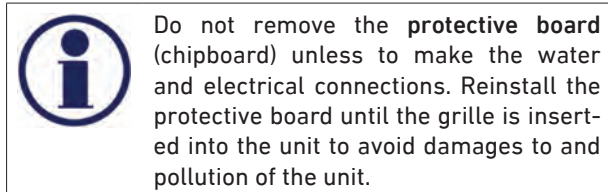

The compact construction with a unit length of 980 mm and a grille frame width of 320 mm means that the unit can be installed between floor supports.

The precise alignment of the unit is achieved using height-adjustable feet that are external to the unit.

The valve chamber used to connect the control valves is located on the opposite side of the facade opening.

Openings for water connection hoses are also located on the opposite side of the facade opening at the rear panel of the facade module.

At the rear part of the unit, it is possible to install base plates with insulating plates on the cover of the blower module.

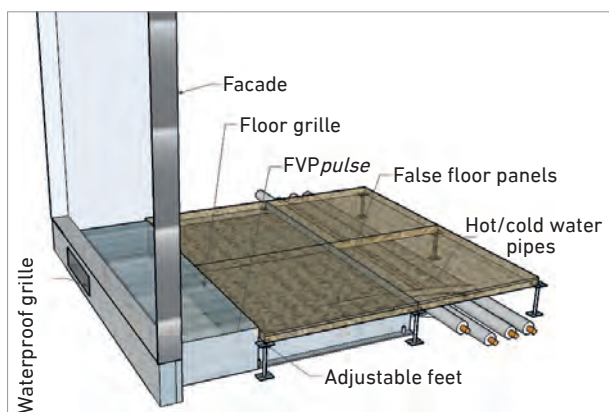

Due to the restricted space available in the valve chamber, connection is only possible using a special valve unit (available as an accessory).

5.2 Unit installation

Observe the following when installing the unit:

- **Supporting feet** must be preadjusted to ensure that the unit's own weight is carried by the supporting feet and not by the outside air socket.
- Tighten the supporting feet's lock nuts, observing a **torque of 3 Nm**.
- The top edge of the unit and hence of the walk-on grille is **flush with the finished floor**;
- Secure the unit against **horizontal shifting**, e.g. by using the fixing links available as accessories.
- Do **not fix other components** to the unit unless with LTG Aktiengesellschaft's express permission and prior release.
- Take care to **avoid any direct contact** between the unit and the raw floor except by the supporting feet to eliminate sound and foot traffic noise transmission.
- Take care to **avoid any direct contact** between the unit and the facade and suction duct to avoid sound transmission, except via seals designed for this purpose (VDE 6022, hydrophobic and closed-pored).
- **an insulating strip** provided by others is fastened between the unit and the facade and between the unit and the floor plates;
- during fixing of the units to the floor using the supplied fastening brackets, a **sound insulation is attached to the bracket underside** to prevent sound transmissions;
- before insertion of the diffusion grille, the **protective film on the cover plate** of the valve chamber is **removed**.



Laying the floor

When laying the floor take special care to avoid any direct contact between the floor boards and the unit, i.e. do not place floor boards directly on the unit and avoid their touching laterally.

Ensure the use of a sound insulation element in between or use an appropriate sealant (see above) between the unit and the false floor's boards.

Installation

5.3 Facade outside air connection

The unit is standard provided with an outside air connection, 107 x 363 mm (may vary depending on project).

We also recommend using a sheet metal duct that should meet the following specifications:

- clear cross-section 370 x 115 mm
- Ideally with a flange for sealing at the unit
- With insulation to prevent thermal bridges in the ventilation duct
- The support should be inserted in the wall opening and be able to move.

The inside connection dimensions must on no account be smaller than 370 mm in width and 115 mm in height, and the seal / insulation must not project into the opening area of the intake, as otherwise the opening of the outside air flap could be obstructed.

When installing the unit take special care:

- to ensure that the outside air duct and the outside air connection are clean;
- to provide proper sealing to the outside air connection using a suitable hydrophobic and closed-pored sealant meeting VDI 6022 requirements;
- Facade connection must be designed in a way to ensure that the speed will not exceed 2 m/s over the entire air intake section if the outside air flow rate is 240 m³/h

Before putting the unit into operation, make sure that the flow path of the outside air to the unit is clean, meeting pertinent sanitation requirements, to avoid immediate contamination of the unit, the filter, and the room to be ventilated.



Ensure that the facade geometry will keep water from entering the outside air connection opening at any time and under any circumstances.

Example of a typical facade installation

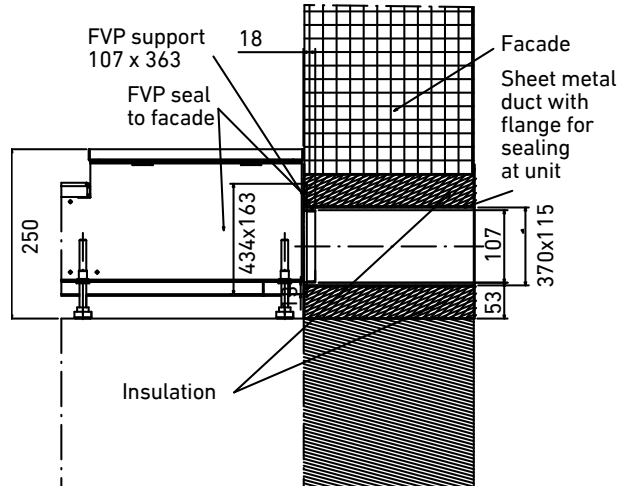

Thanks to the adaptable adjustable feet, the construction tolerances can be optimally compensated for.

With the unit, LTG also supplies a "soft-pad" that performs the following tasks:

- Absorption of relative movements
- Structure-borne sound isolation
- Sealing of the facade against the housing
- Prevention of thermal bridges between the unit and the facade

The figure does not take account of an oblique rain shield that should be mounted at the building. This can, for example, take the form of a waterproof grille and must provide for a slight incline (2...5 %) in the sheet metal duct.

Installation

5.4 Water connections



Remove the heat exchanger plugs prior to water connection!

Units are provided with heat exchangers with copper tubes and aluminum blades for 4-pipe operation with separate heating and cooling circuits.

The heat exchangers have been approved for a maximum operating pressure of 10 bar (other pressures on request).

Water connections are supplied in the following version: 1/2" internal thread fitting, conical sealing.



Always follow the installation instructions for the water connections.

Connections must be stainless.

Connecting lines must be able to expand.

Attention:
Prior to allowing water to enter the , the flexible water connection hoses will have to be checked for proper and leakproof fixation. Even though hoses to the heat exchanger are preinstalled, fastenings might have loosened during transport or installation of the unit on site.

You may use off-the-shelf control valves and shut-off valves, if they allow for **continuous control**. (example: see section 5.1).

When tightening the fittings, avoid damaging the heat exchanger pipes through **bending or twisting**. Pipe fittings must always be flush.

In order to adjust the water volume specified in the selection data, a **regulating device** or restricting olive will be required. A regulating device for each individual unit can be used only when the units are identical, with the same water quantities and the same pressure losses, in the case of the 'Tichelmann system' (reverse return principle). In this case, one regulating device for the entire line may be sufficient. Otherwise, a regulating device will be required for each heat exchanger.

If removal of a heat exchanger without draining the entire system is a requirement, two or four isolation valves will have to be provided for each unit. You may use off-the-shelf **shut-off valves**.

Air can be removed using bleed valves at the heat exchanger.

Due to possible condensation, the connections to the heat exchanger for cooling should be insulated, e.g. using Armaflex insulation.

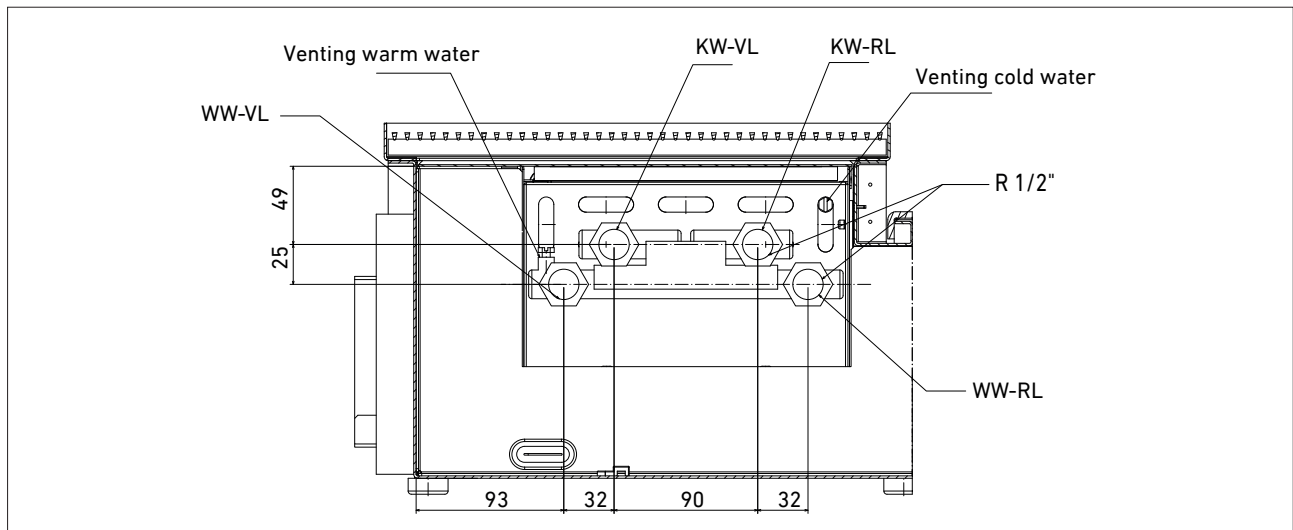

- WW-VL = warm water inlet
- KW-VL = cold water inlet
- KW-RL = cold water return
- WW-RL = warm water return

Installation

Continuation 5.4 Water connections

The special valve unit consists of a through-valve (KVS 0.86) with electro-thermal drive for water-side open/closed control or 0...10 V control, incl. elbow with union nut and flexible hose that is impermeable to oxygen (length: 1100 mm). The return flow screw fittings can also be supplied on request.

During assembly, it is necessary to perform the various steps in the correct sequence (to be performed in the building):

1. Adapter for heating circuit return (1RR; bottom)
2. Connect the corner valve and hose (hose not insulated)
3. Connect the components from 1.) and 2.)
4. Connect the corner valve and hose (hose not insulated)
5. Adapter for cooling circuit return (top)
6. Connect the components from 4.) and 5.)
7. Adapter for heating circuit water supply
8. Valve for heating circuit water supply
9. Hose with 90° elbow (hose insulated)
10. Adapter for cooling circuit water supply
11. Valve for cooling circuit water supply
12. Hose with 90° elbow (hose insulated)
13. Valve drive - heating
14. Valve drive - cooling

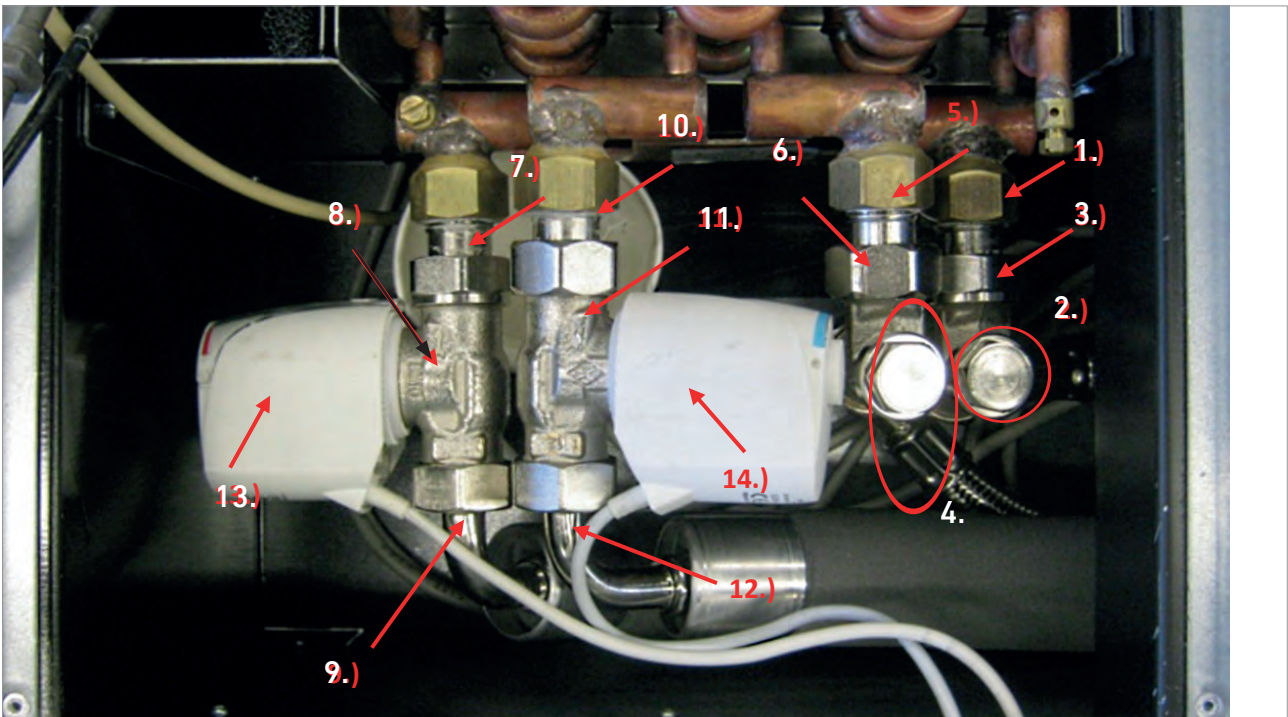

Installation

Continuation 5.4 Water connections

Examples using valve and flexible hose (straight and 90° variant)

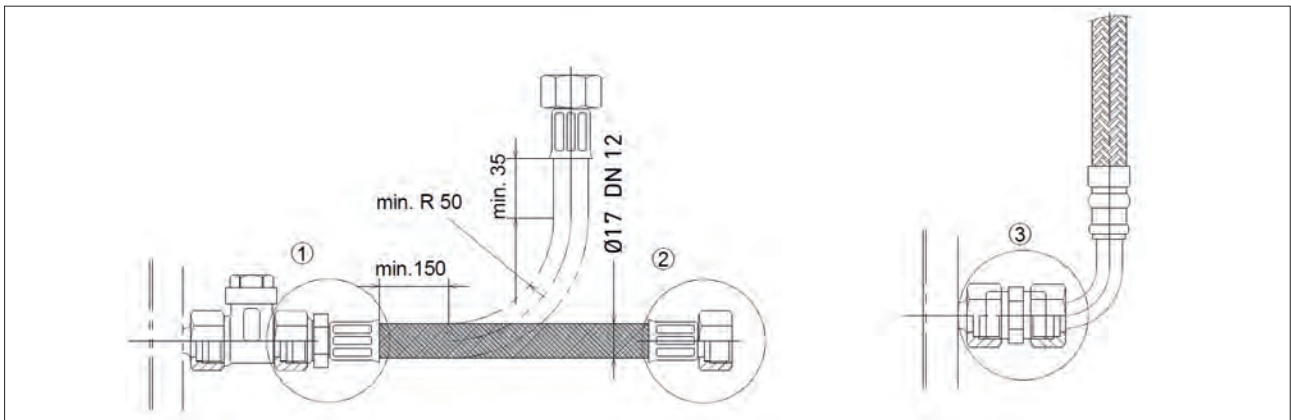

Hose without insulation. For insulated hoses, dimensions will change accordingly.(10 mm Armaflex insulation).

- ① Hose for connection to angle or straight-way valve, connection type AGK, external thread tapered ½ "
- ② Different hose connections, thread diameter acc. to customer requirements or standard ½ "
- ③ Connection for direct screwing into the heat exchanger in case of angle connection, connection type: double nipple ½" - ½"; ÜFD hose connection, ½" flat seal union nut

Example for direct screwing into the heat exchanger

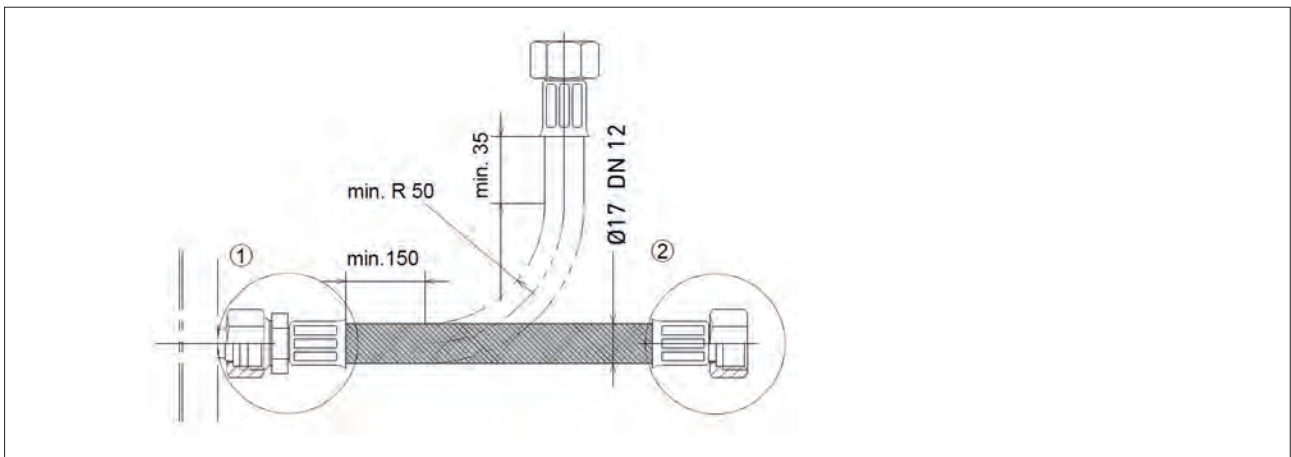

Hose without insulation. For insulated hoses, dimensions will change accordingly.

- ① Connection for direct screwing into the heat exchanger, connection type: AGK, external thread ½", tapered seal
- ② Different hose connections, thread diameter acc. to customer requirements or standard ½ "

Installation

5.4.1 Instructions for installation of water connections using flexible hoses



Warranty will only apply if the following instructions are observed and if installation is performed in compliance with DIN-EN regulations.

In particular, corrosive, electrochemical, and bacteriological charges are to be excluded taking appropriate preventive measures.

correct

incorrect

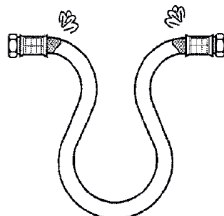
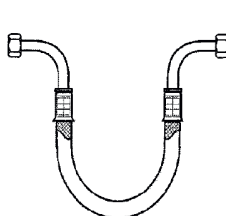
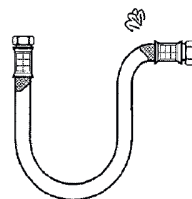
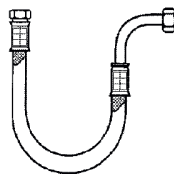
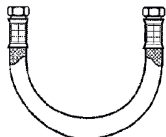
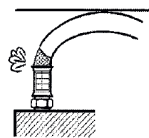
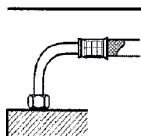
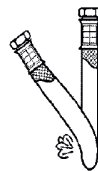
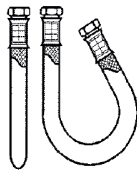

- Pressure and exposition to heat may result in slight elongation of the hose. Therefore, newly placed hoses must consider such potential elongation.
- Do not fall below the admissible bending radius R_{min} (chart), neither during transport, nor during installation or when installed. If it should turn out impossible to keep the admissible bending radius, choose a different installation type.
- For minimum length see chart below. If the hose is being placed by bending it, check whether there is sufficient hose length to allow for an open bow in order to avoid kinking and destruction of the hose at the connecting points.
- Absolutely avoid distorting or kinking the flexible connection.
- Do not subject the hose to any tensile or pressure loads applied from outside, neither during installation nor operation.
- Do not retighten rigid connections (outer thread) after fixing the second connection since this might result in distortion of or damage to the hose.
- In general, tightness of the connection (hose/connector) is the responsibility of the technician performing the installation.
- Any sealing material included in the delivery is to be verified by the technician for its suitability since the hose manufacturer has no information about the material or geometry of the connections.

Installation

Continuation 5.4.1 Instructions for installation of water connections using flexible hoses

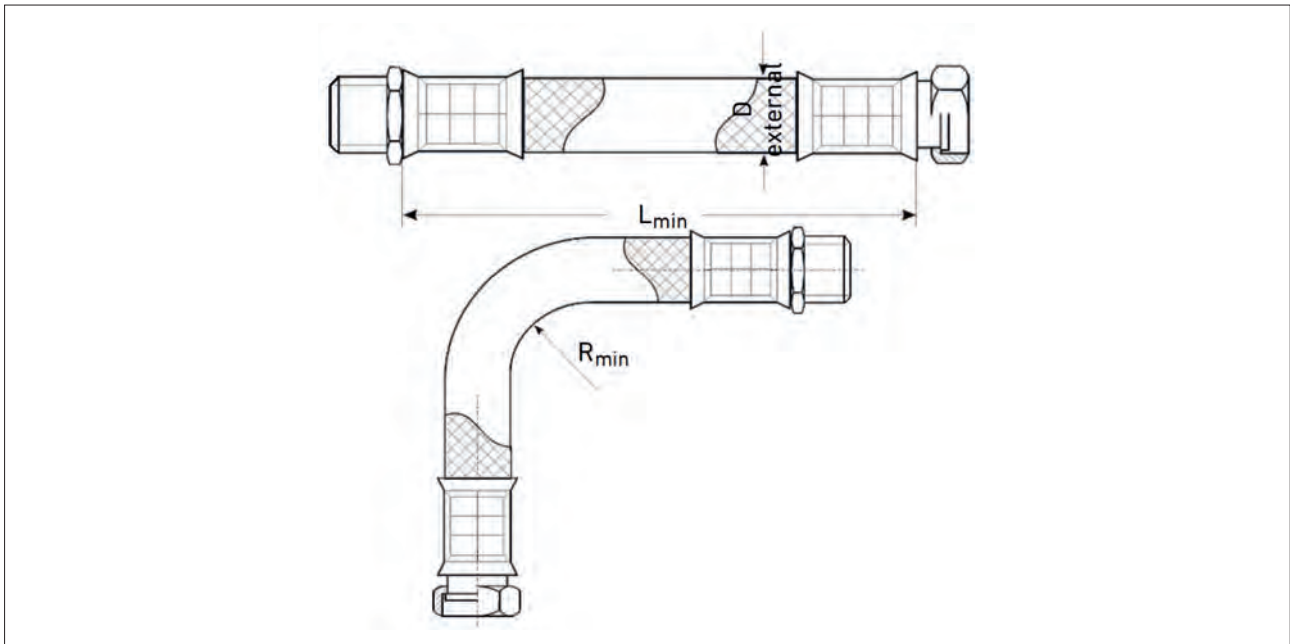

Armoured hose EPDM up to +93 °C (vapour permeable, not marked)

ND hose	D _A	PN [bar]	R _{min}	L _{min}	L _{min} α = 90°	L _{min} α = 90°	L _{min} α = 90°
06/08	12	15	27	6	140	180	260
10	14	15	4	6	190	250	260
12	18	15	6	80	260	360	550
15	22	12	71	95	300	420	640
19	27	1	8	10	650	480	730
25	34	1	10	125	430	590	900
32	44	10	160	140	650	900	1400
40	54	6	180	160	750	1030	1600
50	64	6	230	210	940	1300	2020

Armoured hose vapour impermeable up to +80 °C (marked through weaved-in blue-white strip)

ND hose	D _A	PN [bar]	R _{min}	L _{min}	L _{min} α = 90°	L _{min} α = 90°	L _{min} α = 90°
08	13,5	16 *	110	100	310	490	830
10	16	16 *	130	100	380	580	990
12	17	16 *	150	100	450	680	1150

* at +30 °C / 10 bar at +50 °C

5.5 Condensing operation

The unit is suitable exclusively for non-condensing operation.

5.6 Electrical connection



The unit must be connected to a fault-current circuit breaker (RCD).

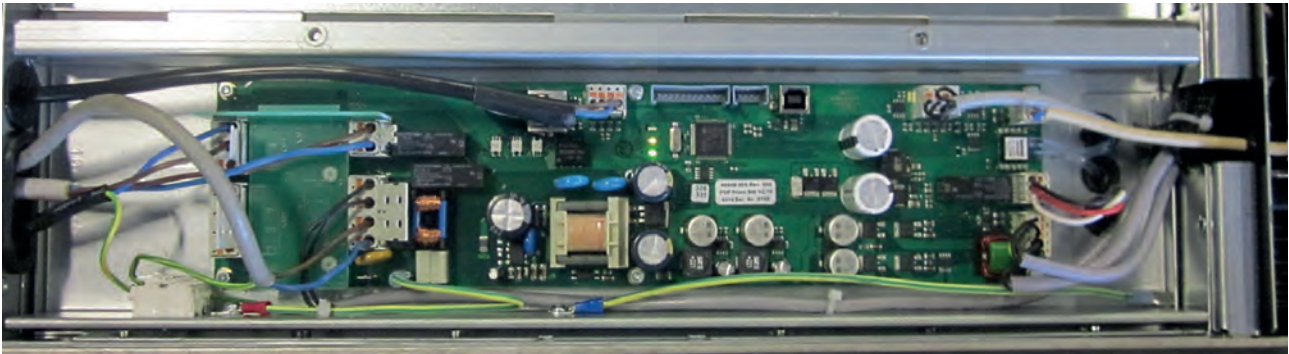

Standard wiring

Enclosure class IP 20

Three outside air flow rates are available and can be selected using a control line. The control line carries a voltage, dependent on the outside air flow rate, at a level up to the mains potential.

Grouped control of up to 3 units is possible (using same phase).

Alternatively, the outside air flow rate can also be continuously selected via a 0...10 V signal.

5.6.1 Fault message

A fault message can be actuated at the terminal box.

The fault message is output for the following operating states:

- Fan not turning despite load
- Frost protection is active (temperature at HE < 10 °C)
- Set flow rate is not achieved within 120 secs.



*Cable leadthroughs.
Internal dimensions
46 x 12 mm*



*Cable leadthroughs for
the Ethernet cable. Max.
cable diameter 8.7 mm.
Hole diameter 11.9 mm*

Installation

5.6.2 ECO control

The ECO control possesses the following internal functions:

Cycle time

The cycle time (e.g. 20 s supply air transport / 20 s exhaust air transport, configurable via the USB port) is constant, the switchover between supply and exhaust mode is controlled automatically via the control board.

Error output

The error output can be read out via a floating contact. A more detailed error analysis is possible via the USB port.

Frost protection

Integrated frost protection prevents the heat exchanger from freezing and causing water damage. If the supplied air temperature falls below 10 °C, the fan switches off and the outside air damper is closed. This operating point can never occur if the unit is functioning in either heating or cooling mode. A fault message is also output via a floating contact.

Flow rate

Available are 3 outside air flow rates. Control is performed via a mechanical 3-level switch or room control (accessories). The control line has an outside air flow-dependent voltage of up to mains potential.

The flow rates for the different levels can be pre-configured via the USB port.

Activation in groups of up to 3 units is possible (using the same phase).

Valve control

The valve is not controlled via the board, but can, for example, be controlled via a room temperature control (available as an accessory).

Master-slave

Communication between the "master unit" and the "slave unit". In master-slave communication, only the master signal is evaluated.

Function	Plug no.	Signal
Flow rate	X300	Phase control L 230 V, 50...60 Hz
Operating mode supply air "BZ" / exhaust air "BA"	X301	Phase control L 230 V AC, 50...60 Hz
Voltage supply	X200	N L 230 V, 50...60 Hz
Error output	X202	Potential-free output
Master-slave communication	X800	Ethernet connection

The feed line must be protected with an external line protection with 2 A nominal current and at least tripping characteristic D (fuse or LSS). The cable used for the feed line (cross-section and type of installation) must be matched to the line protection used.

The board is located in the device. Viewed from the room, it is on the left under the tread-resistant floor grille.

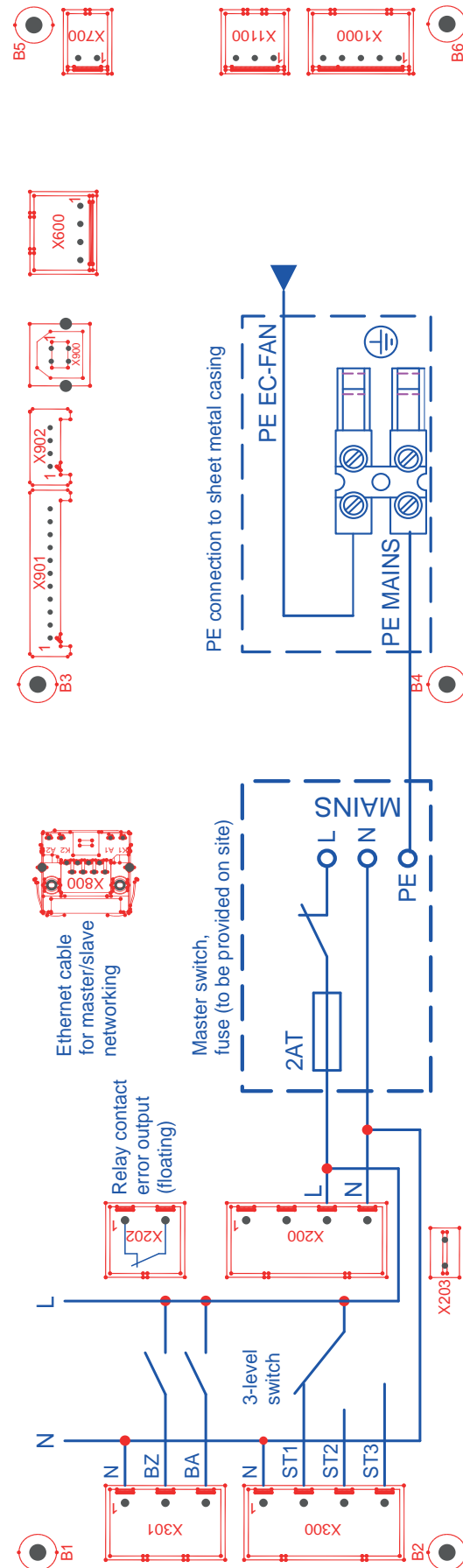

Installation

5.6.3 PREMIUM/control

The Premium regulator/control offers the same capabilities as the ECO regulator/control, together with the following additional functions.

Wind pressure control

An intelligent control mechanism adapts the transported supply and exhaust volume flows accordingly when there is an under-pressure or over-pressure at the facade. In the FVPpulse ventilation unit, this is achieved by the asynchronous control of the supply and exhaust air flows.

Continuous flow rate control

The flow rate can be adjusted continuously from 0...120 m³/h via an analogue signal (0...10 V DC) both in stationary mode (either only supplied air or only exhaust air, 0...240 m³/h) and in non-stationary mode.

Continuous adjustment of the cycle time

The cycle time for supplied and exhaust air transport can be adjusted continuously from 10...80 s by means of an analogue signal (0...10 V DC). This results in the heat recovery levels indicated in the diagram on page 9.

Function	Plug no.	Signal
Flow rate	X300	Phase control L 230 V, 50...60 Hz
Operating mode supply air "BZ" / exhaust air "BA"	X301	Phase control L 230 V AC, 50...60 Hz
Voltage supply	X200	N L 230 V, 50...60 Hz
Error output	X202	Potential-free output
Master-slave communication	X800	Ethernet connection

The feed line must be protected with an external line protection with 2 A nominal current and at least tripping characteristic D (fuse or LSS). The cable used for the feed line (cross-section and type of installation) must be matched to the line protection used.

The board is located in the device. Viewed from the room, it is on the left under the tread-resistant floor grille.

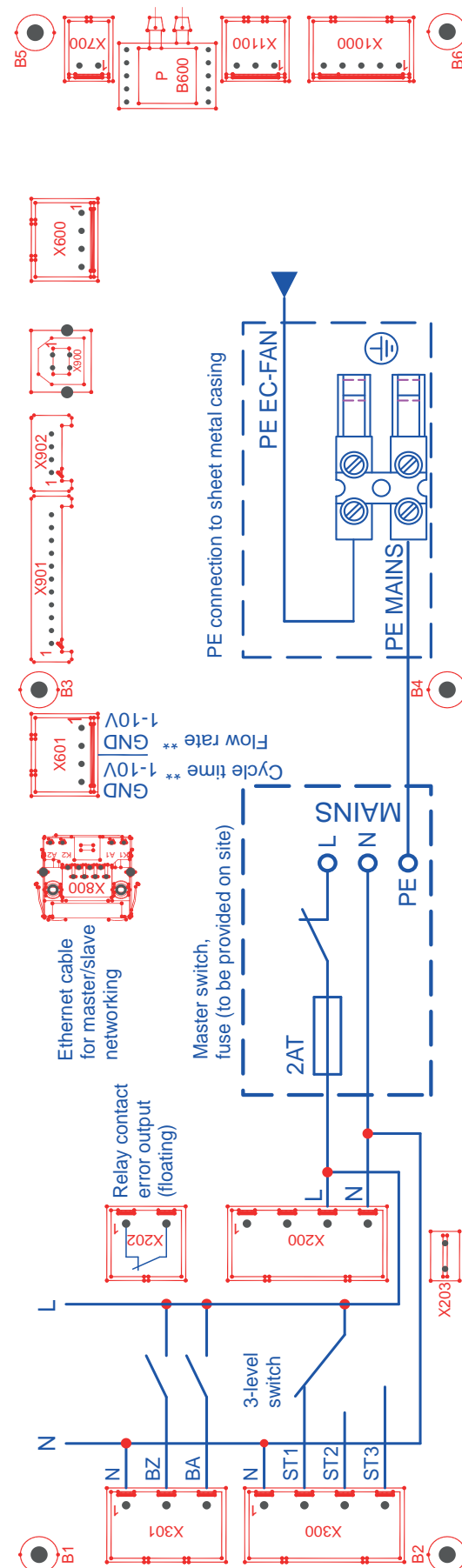

Installation

5.6.4 Electrical specifications of the plug-in connection

Designation	Spring-loaded terminal blocks	Connector number	Module dimension, orientation	Voltage / specification
Error output	Pico Max Wago	X202	MD 7.5 mm Orientation 180 °	230 V AC 50...60 Hz
3-level switch	Pico Max Wago	X300	MD 7.5 mm Orientation 180 °	
Mains supply	Pico Max Wago	X200	MD 7.5 mm Orientation 180 °	
Operating mode (BZ, BA)	Pico Max Wago	X301	MD 7.5 mm Orientation 180 °	
Flow rate / cycle time **	Pico Max Wago	X601 *	MD 3.5 mm Orientation 180 °	0...10 V DC R _{in} approx. 30 K-Ohm
USB service port	USB type B socket	X900	Orientation 180 °	
Networking	Ethernet cable	X800	Orientation 90 °	

* The 0...10 V signals must be transmitted via a screened cable

** The cable leading from the RJ45 socket out of the unit and used for master-slave communication (RJ45 connection) must be rated for a mains voltage of 300 V / 500 V at 20 °C. For example, the cable Ölfex Heat 205 MC from the "Lapp Group" can be used here.

5.6.5 Wiring

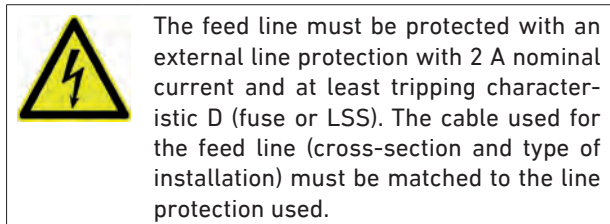

- Local regulations relating to wiring, fuses and earth bonding must be adhered to.
- The cables to the unit carry a mains voltage of 230 V AC and must be dimensioned accordingly.
- The supply cable must be protected by an external fuse or a circuit breaker.
- The lines for the control voltages (0...10 V DC, for example for flow rate / damper rest time) must be equipped with adequate cable screening.

5.6.6 Error output

The (floating) error output closes if

- the frost protection function is triggered
- an internal cable breakage occurs
- internal components malfunction
- an impermissible command is received (e.g. supply and exhaust mode selected simultaneously)
- there is no voltage supply to the unit

A more detailed analysis of the fault can then be performed via the USB port.

With a master-slave combination, a possible fault message is transmitted from a master unit to the slave unit and can be accessed using the potential-free contact (X202).

5.6.7 Interface

The control can be connected to a PC using an A/B USB cable. As a result a new serial interface is installed on the PC. Using a terminal program (e.g. TeraTerm free-ware), a connection to the control system can then be established.

```

/system status LTG FVPpulse V3.9 chk:9AF6 PREMIUM
-----
inputs      inputs      setpoint  setpoint  temperature
room controller night airing air flow  flap rest period sensor
RR1 RR2 RR3  RL1 RL2    voltage  voltage  centigrade
-----
0 0 0 1 0 0.00 V 0.00 V 23.1
-----
mode of analog input flap rest period  ANA_KRZ 2 on & not controlled
mode of analog input air flow input    ANA_GLT 2 on & not controlled

operatin mode : night inlet airing          single system
system status : no error
power pack    : is online UC02V5 2.34 V UC02V5 2.47 V UCSV 4.81 V
set point air flow : 4.40 V U24V 23.64 V
just value air flow : 4.39 V :1801 digital
outside flap   : open
airing direction : input Pause: 0,0 s
flap position  : 4
flap current   : 0.00 A
input idle period : 10.0 s mitHDR: 10.0 s
output idle period : 10.0 s mitHDR: 10.0 s
-----
current pressure differential : 24.88 Pa tEinschwing 5
differential pressure input : 0.00 Pa tMax: 0.0 s
differential pressure output : 0.00 Pa tAus: 0.0 s
setpoint over pressure : 7.50 Pa DU_kp 20
Diff_00_Eim400_RUS : 0.00 Pa PauseADR: 0.0 s
Quotient 00ein/00aus : 0.00
-----

```

TeraTerm software monitor for output of system status and error messages during operation.

Installation

5.7 Check after installation



Verify for the unit's proper connection to a residual current device (RCD).

Mechanical check

Having completed the installation, the unit is to be checked for any mechanical damages. Reminders of the packaging material and dust in or on the unit must be removed..

The following must be inspected:

- VDE-compatible design,
- leakproofness of the water connections (including heat exchanger connections),
- careful execution of the insulation of all components carrying cold water to the heat exchanger,
- the fixing screws for proper fit,
- the unit for not contacting the facade and the raw floor except via the seals provided and the supporting feet (floor units),
- correct installation of the fine filter (flow direction),
- the line voltage and frequency to match the data given on the type plate,
- the electrical connections for proper execution and conformity to pertinent regulations,
- proper functioning of the controls (optional),
- proper functioning of the motors (fan, actuators) without friction noises,
- the unit's mounting,
- the diffusion area/diffusion grille of the unit to be free of any obstructions,
- proper horizontal alignment, accurate to dimension,
- sufficient water hose lengths and strainless installation,
- if applicable, checking of the tightness of the unit's connection to the intake duct for outside air,
- protective board (chipboard) removed

Check for media supply

- Check for proper availability of primary air, cold water, warm water, and electrical power.
- Check whether voltage and line frequency comply with the data given on the actuator's type plate. Never operate control devices with inappropriate voltage or frequency since this might result in destruction of the units and put people at risk.

Control technical equipment

Supply of control devices by LTG Aktiengesellschaft is optional. Control valves are often factory-mounted.

Starting standard operation

Then set the temperature controller to the desired temperature. After a certain time, the indoor air temperature should meet the setpoint.



The full extent of the ventilation, air-conditioning and control engineering systems is not known to us as a rule. All drafts, designs and circuitry proposals therefore show only those systems relevant for the principal functions.

Units or components needed for, for example, the overall control function and/or VDE-compatible construction are neither taken into account nor explicitly indicated.

First use

6. First use

Prior to first use all installation work and all checks must have been completed.

Check for proper water and power supply.

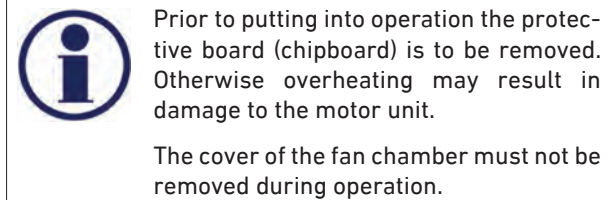

Having started the unit, an air flow should be perceivable from the floor grille. Only very minor air diffusion and motor sounds should be audible. Other sounds such as friction or impact might indicate damage resulting from transport or installation.

At the first mains connection, first the capacitor must be charged. **The unit can therefore only come into operation after 5 minutes.**

The unit's primary function is to provide fresh air to the room. In case of extremely high or low outside air temperatures or in case of high thermal loads, the unit's capacity might be insufficient to maintain the desired room temperature. Therefore, it is usually combined with other indoor air conditioning systems such as concrete core temperature control.

6.1 Emergency closing function

In case of an emergency such as fire or "gas alarm", it is desirable to keep outside air from entering and to seal the facade.

The decentralised ventilation unit has for that purpose an actuator motor on the outside air flap which is fed by the capacitor of the control board. If the power fails or is switched off, the outside air flap closes automatically.

6.2 Selecting the outside air flow rate

The decentralised ventilation unit can be switched "Off" at the room control unit (provided by others) after correct installation,

- for example when the phase L was not actuated at the 3-stage switch (connector X300 in the ECO board),
- for example when the voltage (connector X601 in the Premium board) is <1 V.

The outside air flow rate related to each speed level is usually preset according to customer's and project requirements.

Assuming normal functioning, the outside air flap opens when the unit is switched on, then the fan starts to operate and the switchover of the air directions by the flap kinematics begins. Outside air is sucked in through the filter and then blown into the room either heated or cooled by the heat exchanger.

It is recommended to select the outside air flow rate in compliance with your needs, e.g. depending on the number of persons gathered. Please refer to the minimum air volume regulations of DIN EN 16798 Part 1. On the other hand, the outside air flow rate should be kept as low as possible to save energy.

Here a few ideas how to use the unit efficiently:

- Switch the unit off or set it to a lower level if the room is not being used.
- If opening the windows is permitted, switch the unit off while windows are open or in between seasons.
- Switch the unit to a lower level during winter and when the outside air temperature is very low if you think that sufficient fresh air is entering the room and that the indoor air is quite dry.

First use

Continuation 6.2 Selection of the outside air flow rate

Hybrid ventilation

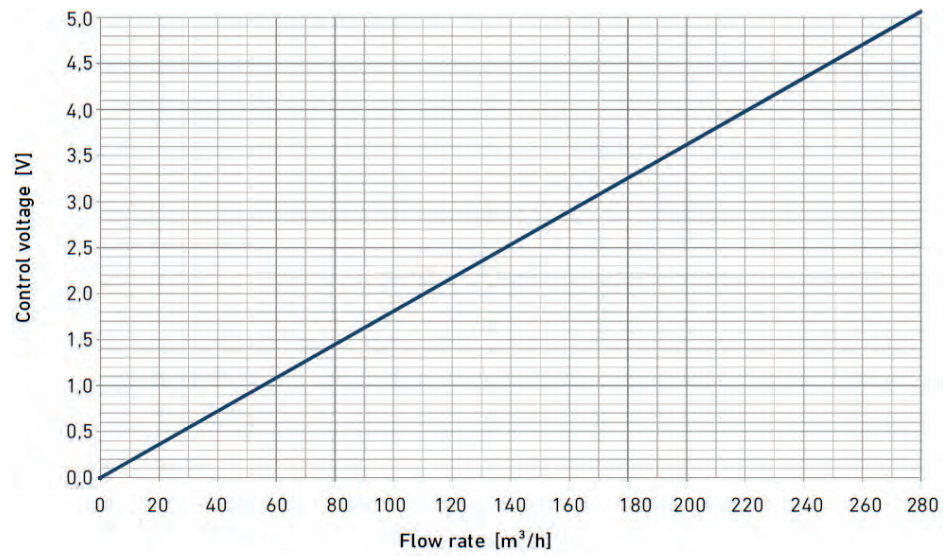

Cyclical mode of operation

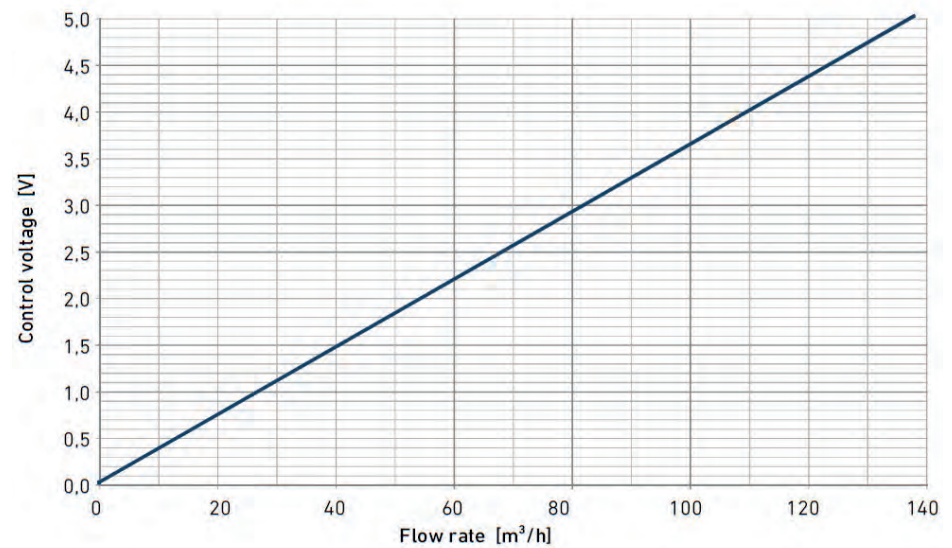

First use

6.3 Programming instruction

The control can be connected to a PC or laptop using an A/B USB cable.

The appropriate parameters can be altered here using a terminal program (e.g. TeraTerm).

6.3.1 TeraTerm operating interface

Before connection, the PCB (ECO or Premium) must be connected to the supply voltage (230 V AC).

Connect the control unit using an A/B USB cable to a PC and connect (open) it using TeraTerm.

COM port and interface parameters must be set using "Settings" and "serial port" (Figs. 1...3).

The interface parameters are:
 115200 Baud
 8N1 (8Bit, no parity, 1 stopbit)

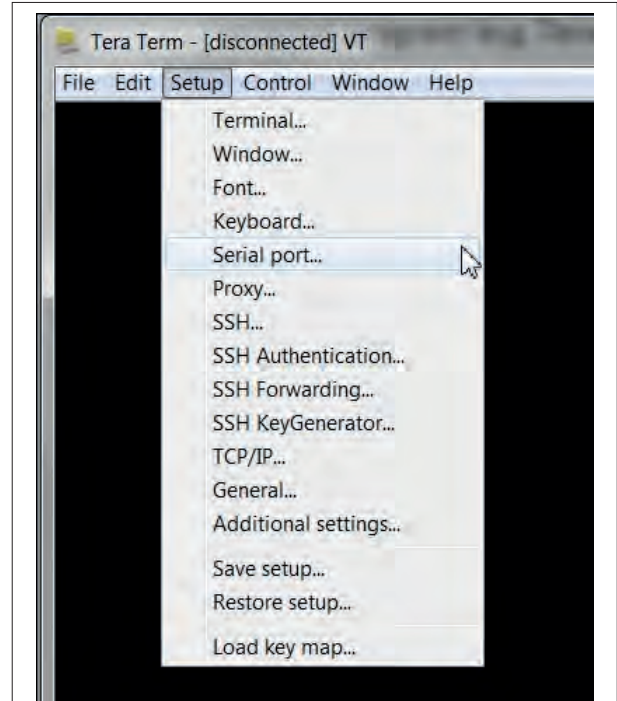

Fig. 1

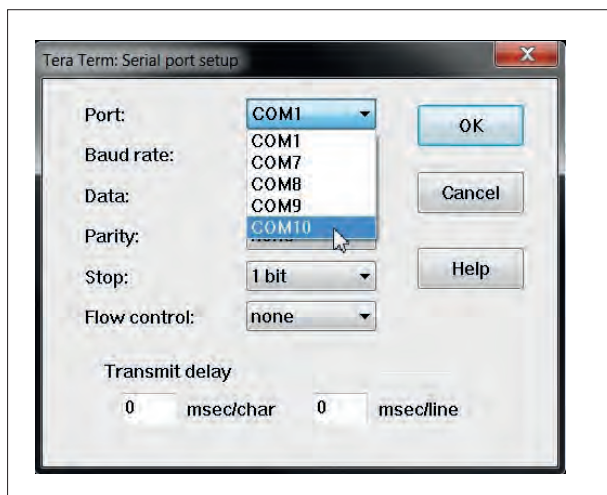

Fig. 2: Example for selection of COM port

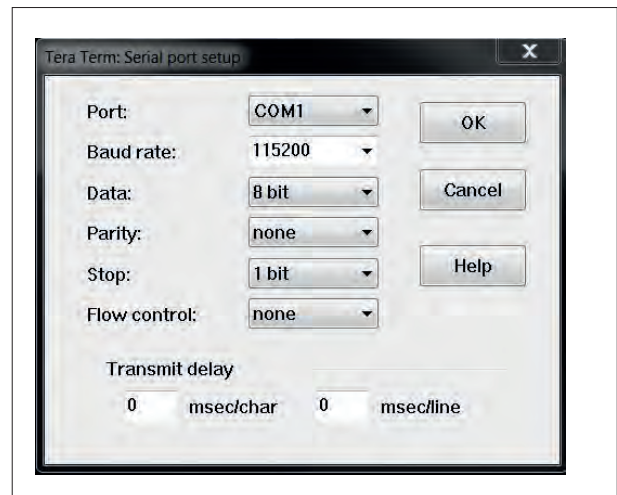

Fig. 3: Example for setting of the Baud rate

First use

Continuation 6.3.1 TeraTerm operating interface

Display of the general system status

The general system status is displayed with the command "as" (Figure 4).

```

COM123:115200baud - Tera Term VT
Datei Bearbeiten Einstellungen Steuerung Fenster Hilfe
system status LTG FVPpulse V3.9 chk:9AF6 PREMIUM .
-----
inputs      inputs      setpoint      setpoint      temperature
room controller night airing airflow  flap rest period sensor
RR1 RR2 RR3  NL1 NL2      voltage      voltage      centigrade
-----
0 0 0      1 0      0.00 V      0.00 V      22.7
-----
mode of analog input flap rest period      ANA_KRZ 2 on & not controlled
mode of analog input air flow input      ANA_GLT 2 on & not controlled

operatin mode      : night inlet airing      single system
sytem status      : no error
power pack      : is online UCu2V5 2.32 V UCc2V5 2.46 V UC5V 4.78 V
set point air flow : 4.40 V U24V 23.57 V
just value air flow : 4.39 V :1801 digital
outside flap      : open
airing direction  : input      Pause: 0,0 s
flap position     : 4
flap current      : 0.00 A
input idle period : 20.0 s      mitHOR: 20.0 s
output idle period : 20.0 s      mitHOR: 20.0 s
-----
current pressure differential : 23.55 Pa tEinschwing 5
differential pressure input : 0.00 Pa tMax: 0.0 s
differential pressure output : 0.00 Pa tAus: 0.0 s
setpoint over pressure : 7.50 Pa DD_kp 20
Diff. DD_Ein+DD_AUS : 0.00 Pa PauseHOR: 0.0 s
Quotient DD_ein/DD_aus : 0.00
-----
runtime_8h 0 runtime_s 25556
timeout moving flap= 60 time system error=3005 starttime fan= 52
over-current 0 limit 0
reason last over-current learning position
>level 23
service level enabled temporary enabled
>

```

Fig. 4: Example of system status

First use

Continuation 6.3.1 TeraTerm operating interface

Display of access rights

The current access rights are indicated with the command "h" (Figure 5).

```
>h
-----
Helpmenu - LTG FVPpulse V3.9 chk:9AF6 PREMIUM
-----
current user level = service level
-----
level <code>          set userlevel
ed                   dump all eeprom data
pute <adr> <val>      write word to eeprom adress
werkseinstellung oder  setzt alle Parameter zurueck
defaultinit          setzt alle Parameter zurueck
io1 ... io5          I/O und Infenster
(g)lete <adr>        read word from eeprom adress
as                   Anlagenstatus anzeigen
reset                Systemreset
error                Fehlerspeicher anzeigen
(h)help              this screen
>
```

Fig. 5: Example of access rights

Extension of access rights

The command for expansion of the access rights is available on request (Technical Service of CMRK).

Error memory

The command "error" accesses the error memory (Figure 7). The latest error is at the top. If the memory is full, the oldest error "drops off at the bottom".

```
>error
-----
no current error
-----
ringbuffer start-adr: 360 newest error at no: 0
-----
no: 0 adr:360 error-no:220 ==> sytem start
no: 1 adr:359 error-no:999 ==> time: 24874 s
no: 2 adr:358 error-no:999 ==> time: 00000 s
no: 3 adr:357 error-no:999 ==> time: 00000 s
no: 4 adr:356 error-no:220 ==> sytem start
no: 5 adr:355 error-no:999 ==> time: 24866 s
no: 6 adr:354 error-no:999 ==> time: 00000 s
no: 7 adr:353 error-no: 93 error: supply 12V out of range
no: 8 adr:352 error-no:999 ==> time: 24866 s
no: 9 adr:351 error-no:999 ==> time: 00000 s
no: 10 adr:350 error-no:220 ==> sytem start
no: 11 adr:349 error-no:999 ==> time: 09418 s
no: 12 adr:348 error-no:999 ==> time: 00000 s
no: 13 adr:347 error-no:220 ==> sytem start
no: 14 adr:346 error-no:999 ==> time: 09337 s
no: 15 adr:345 error-no:999 ==> time: 00000 s
no: 16 adr:344 error-no:205 ==> power down by user
no: 17 adr:343 error-no:999 ==> time: 09337 s
no: 18 adr:342 error-no:999 ==> time: 00000 s
no: 19 adr:341 error-no:220 ==> sytem start
-----
next page with n \ cancel with any key
>
```

Fig. 6: Error memory

First use

6.3.2 Parameter programming

Before parameterisation, the unit must be completely fitted and the board (ECO or Premium) connected to the supply voltage (230 V AC).

Connect the control unit using an A/B USB cable to a PC and connect it using a terminal program (e.g. TeraTerm).

The interface parameters are:
115200 Baud
8N1 (8Bit, no parity, 1 stopbit)

A parameter is written with the command "pute". This is followed by a blank, then appropriate address, a further blank and the value to be filed. Example:

To set the cycle time of the flap to 2 x 20 sec, the following command is entered: **pute 135 20000**

To output the filed value of a parameter, the address must be entered with the command "g" and blank: **g 135 (as an example)**

The board is divided into three different user stages (with appropriate authorisations). These stages are "user", "service" and "system". The standard setting is the lowest authorisation stage ("user", read-only). To implement changes in the parameterisation, the authorisation stage "service" is needed and therefore "programmed" first.

Parameter	Address	Value	Description
Service	level	23	
Fan stage 1	129	100...1000	1...10 V (Standard = 220)
Fan stage 2	130	100...1000	1...10 V (Standard = 330)
Fan stage 3	131	100...1000	1...10 V (Standard = 440)
night-time ventilation, supply air	132	100...1000	1...10 V (Standard = 440)
night-time ventilation, exhaust air	133	100...1000	1...10 V (Standard = 440)
Cycle time	135	5000...40 000	Standard = 20 000 (2 x 20 sec)
Frost protection temperature	155	100	10
Hysteresis of frost protection	156	30	3 °C (T > 13 ° switches on the FVP).
Single unit	169	0	Standard
Master	169	2	
Slave	169	1	
Night-time ventilation, master-slave	170	0	Standard (master and slave in inverse operation)
Night-time ventilation, master-slave	170	>0	Master and slave in parallel operation

All further parameters on request (Technical Service of CMRK).

6.3.3 Software programming

Before parametrization, the unit must be completely fitted and the board (ECO or Premium) connected to the supply voltage (230 V AC).

Connect the control unit using an A/B USB cable to a PC and connect it using a terminal program (e.g. TeraTerm).

The interface parameters are:
115200 Baud, 8N1 (8Bit, no parity, 1 stopbit)

A new firmware (= application) can be added to the control via the monitor interface. To do so, it is essential that the bootloader is present in the program memory (normally it is already installed).

After system start (supply voltage applied), the bootloader waits 5 seconds for an input, then branches to the application, if this is provided. By entering "load" during these 5 seconds, the bootloader is set to receiving mode. It deletes the old application and is ready to receive the new "hex-file". "Send file" is used to send this file and the bootloader programs it into the flash of the controller.

After completion of programming, the board starts by itself.

Operation, maintenance, repair

7. Operation, maintenance, repair

For operation and maintenance of the units, the following points must be complied with:



Any maintenance and servicing work must be performed by skilled, licensed and trained staff only.

Before starting the maintenance, pull the mains plug and disconnect the device from the power supply on all connections; secure it against reactivation.

7.1 Repair

Unless the damage is obviously just dents in the sheet metal, e.g. at the outlet, defective units should be replaced complete for inspection at the factory.

First, the unit is to be completely disconnected from the power supply by an expert.



The panels supplied by others are also intended for protection and may only be removed for maintenance and cleaning.

Replacement of the control unit should be performed by skilled staff only or by the factory.

Replacement of individual components, e.g. a fan bearing, is not recommended since adjustments can only be performed in the factory using special equipment

Warranty applies to complete fans only.

7.1.1 Filter change in the exhaust air filter

It is recommended that the filter be changed when required, but at least every 12 months.

For maintenance or repair work, first the floor grille must be lifted out. This makes the valve cover and heat exchanger accessible.

Step 1: Open floor grille



Step 2: Open valve cover



Step 3: Take out exhaust air filter



Operation, maintenance, repair

7.1.2 Filter change in the outside air filter

It is recommended that the filter be changed when required, but at least every 12 months.

Step 1: Remove floor grille

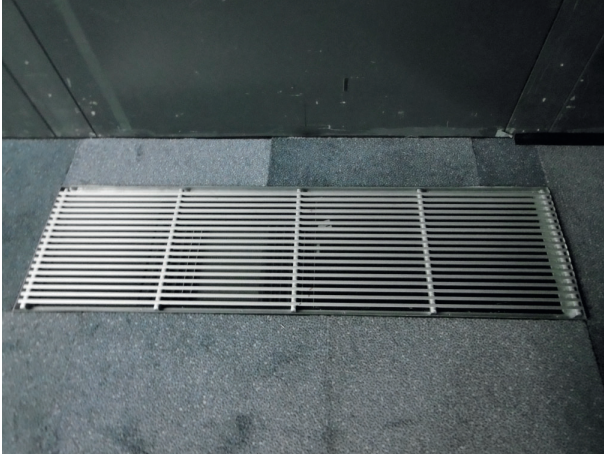

Step 3: Remove lower filter cover

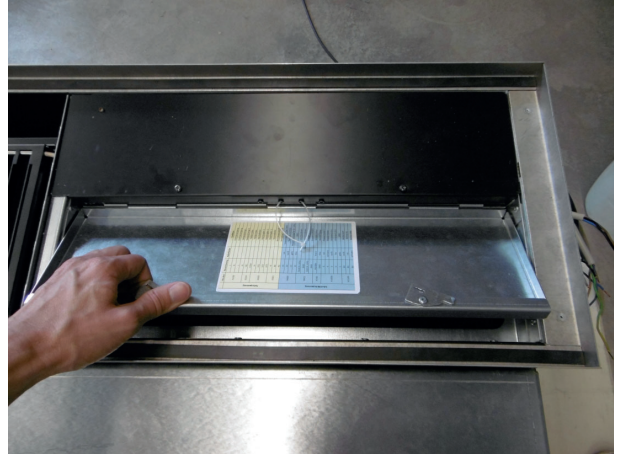

Step 2: Remove upper filter cover



Step 4: Change filter



7.2 Maintenance

The specified activities should be performed, depending on environmental effects, about every 6 to 12 months.

We recommend

- doing the first filter change after commissioning,
- doing the filter change in late autumn, in order not to leave coarse dirt due to airborne pollen etc. inside the filter over winter.

With a six-monthly filter change, the change is also recommended in spring after the end of the heating period.

The filter effect and pressure loss of the fine filter have been developed especially to suit this product. To ensure full operational capability, the replacement filter should be obtained exclusively via LTG Aktiengesellschaft.

7.1.2 Component maintenance schedule

See chapter 10.1 Component maintenance schedule / Maintenance protocol

Operation/maintenance/repair

8. Spare parts, accessories

The following spare parts are available and may be ordered from LTG Aktiengesellschaft stating unit type and description:

Quant.	Ident No.	Spare part	Minim. order quantity
1	1068688	Filter foam for exhaust air filter: 2000 x 1000	1
1	1067526	Filter (comparable to filter class F7)	1
1	1065357	Heat exchanger	1
1	1060378	Fan K3G190-RC0503	1
1	1065350	Heat recoverer	1
1	1066875	Outside air flap Belimo CM 24 L	1
1	1064351	ECO board	1
1	1064353	PREMIUM board	1
1	1065169	Gear motor for the flap mechanism	1

9. Decommissioning, disposal

When the unit is taken out of service, is no longer used and is disposed of as waste, the following must be complied with:

- all steel parts are waste for recycling
- all plastic parts are waste for recycling
- all secondary substances and lubricants must be disposed of in accordance with the provisions of the EWC (European Waste Catalogue) classification.
- Silencers are waste for recycling
- Heat exchangers are waste for recycling (copper, aluminium)

10. Annexe

10.1 Component maintenance schedule / Maintenance protocol

Room control (optional)

Component	Activity	Performance		Executed	
		Months	When required	yes	no
Room control unit	Check for soiling, damage, corrosion and incorrect functioning	12			
Room control	Check supply air temperature limit	12			

Unit

Component	Activity	Performance		Executed	
		Months	When required	yes	no
Unit in general	Check for soiling, damage, corrosion and incorrect seating, incorrect fastening	12			
	Check for tight seating of intake connection to outside air intake duct	12			
	Check for tight seating of unit on the facade and double floor	12			
Fan(s)	Check for soiling, damage, corrosion and incorrect fastening	12			
	Function-preserving cleaning	12	x		
	Check bearings for noise	12			
	Check vibration damper function	12			
	Check protective unit for function	6			
	Check hygienic state	12			
Intake/ pressure room	Check for soiling, damage and corrosion				
	Function-preserving cleaning		x		
	Check thermal insulation for damage (visual check)		x		
	Cleaning interiors of chambers		x		
	Check hygienic state		x		
Valves and valve drives	Check for soiling, damage, corrosion and incorrect functioning	12			

Operation/maintenance/repair

Continuation 10.1 Component maintenance schedule / Maintenance protocol

Unit

Component	Activity	Performance		Executed	
		Months	When required	yes	no
Fine filter	Check for soiling, damage and corrosion	x			
	Check filter support for tightness	x			
	Change and document filter medium	12			
	Check hygienic state	6			
Flap motor for outside air flaps, flap kinematics	Check outside for soiling, incorrect fastening, damage and corrosion	12			
	Function-preserving cleaning		x		
	Check connection terminals for firm seating		x		
	Check for smooth running and heating up		x		
Check safety equipment function	1				
Outside air flap with seal	Check for soiling, damage, corrosion and incorrect mechanical functioning	12			
Duct from filter to heat recovery unit	Check duct section including thermal insulation and fasteners provided for outward damage and corrosion		x		
	Check duct section interior randomly for soiling (visual check), hygienic state.		x		
Heat exchanger	Check for soiling, damage and corrosion	6			
	Function-preserving cleaning (air side)		x		
	Check of water connections	12			
	Bleeding		x		
Check hygienic state	6				
Frost protection sensor	Check for soiling, damage and corrosion	1			
	Check safety equipment function (frost protection)	12			



**AIR TECH
SYSTEMS**

Comfort Air Technology

Air-Water Systems
Air Diffusers
Air Distribution

Process Air Technology

Fans
Filtration Technology
Humidification Technology

Engineering Services

Laboratory Test / Experiment
Field Measurement / Optimization
Simulation / Expertise
R&D / Start-up

LTG Aktiengesellschaft

Grenzstrasse 7
70435 Stuttgart
Germany
Tel.: +49 711 8201-0
Fax: +49 711 8201-720
E-Mail: info@LTG.net
www.LTG.net

LTG Incorporated

105 Corporate Drive, Suite E
Spartanburg, SC 29303
USA
Tel.: +1 864 599-6340
Fax: +1 864 599-6344
E-Mail: info@LTG-INC.net
www.LTG-INC.net