

BVAV-2

Circular variable/ constant
flow device

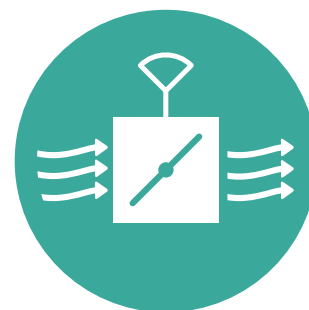

VAV, CAV & FLOW
MEASURING DAMPERS

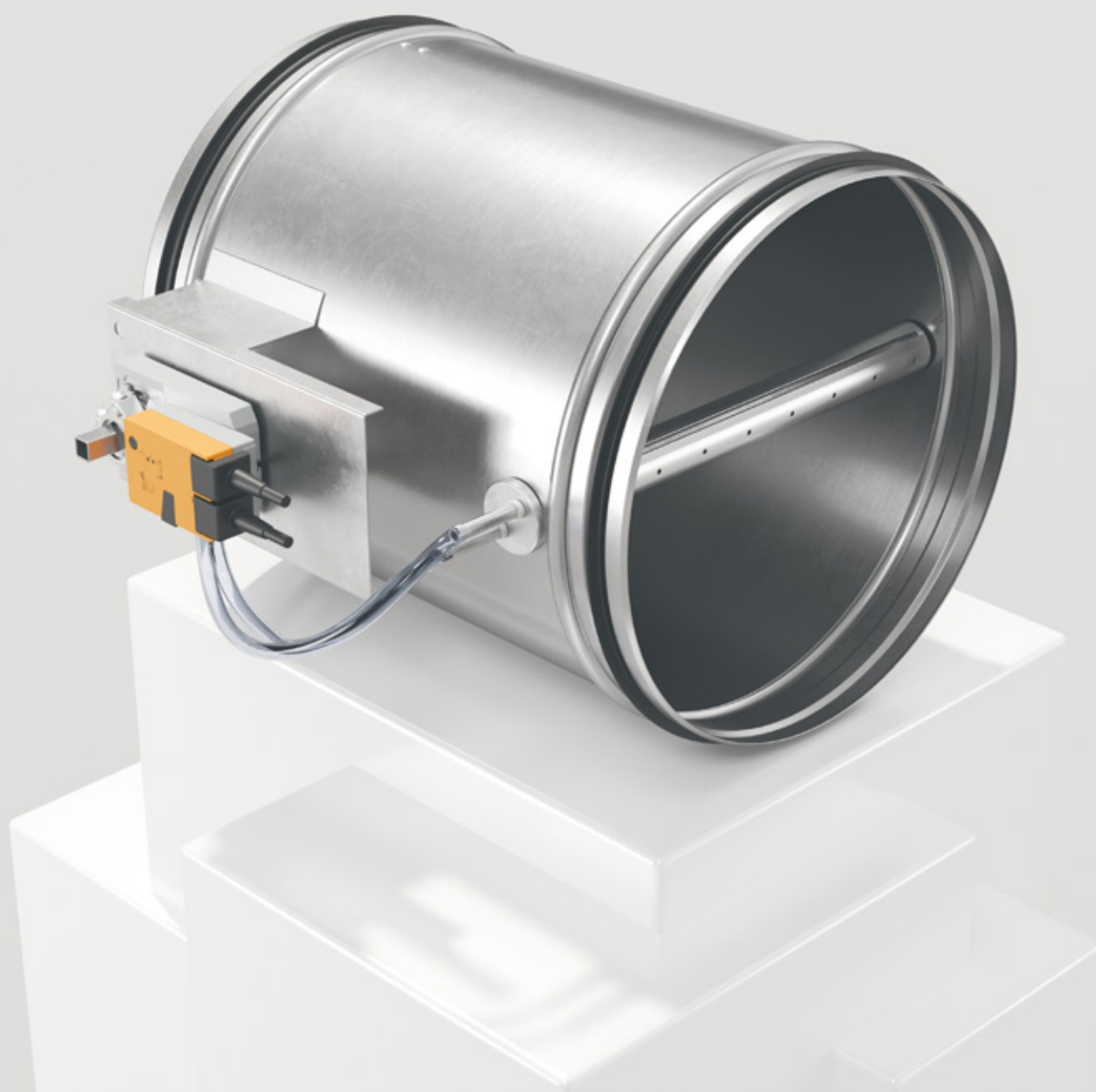

14/09/2021

www.bevent-rasch.com



BEVENT RASCH

AIR SOLUTIONS – FOR A BETTER TOMORROW



Quick facts

- Sizes Ø100 mm to Ø630 mm
- Compact design. Dynamic pressure sensor.
- Factory-set max and min flows
- Calibrated at the factory
- Possibility of adjusting flows on site using a mobile phone (NFC) or with the ZTH handheld device
- Available in MagiCAD

Use

BVAV-2 is a variable/constant flow device with a Belimo compact actuator that features an integrated measurement unit and regulator. The airflow device is supplied calibrated from the factory where selected max. and min. flows are programmed. The flows can be changed manually on site with the ZTH handheld device or with a mobile phone (NFC). BVAV-2 can be ordered with several different communication options such as Modbus RTU, BACnet MS/TP and KNX.

Special

Actuators with spring return or measurement units with static pressure sensor can be ordered as a special option and are then equipped with Belimo's VRU regulator. If any other make of actuator is required, special solutions can be supplied, e.g. Siemens, Schischek and others.

Material, surface treatment

Casing and components of hot-dip galvanized sheet steel according to corrosion class C3. The measurement tube is made of extruded aluminium. The damper is supplied as standard in pressure class A and leakage class 2. Alternative casing and component materials available on request for higher pressures and environmental requirements.

Specification

Example:

**Variable/Constant airflow device
BVAV - 2 - 160 - 1 - 200/100**

Size, Ød mm as per size table

Actuator, communication:

Standard, MP-bus = 1
ModBus RTU, BACnet MS/TP = 2
KNX = 3

Set airflow, max/min air flow, l/s

NOTE! If the devices are to be used as master/slave this must be specified.

Accessories

Union piece

Air quality sensor T-SENSE VAV

Timer TEL-2

Silencers

Temperature regulator TR24-M



Dimensions

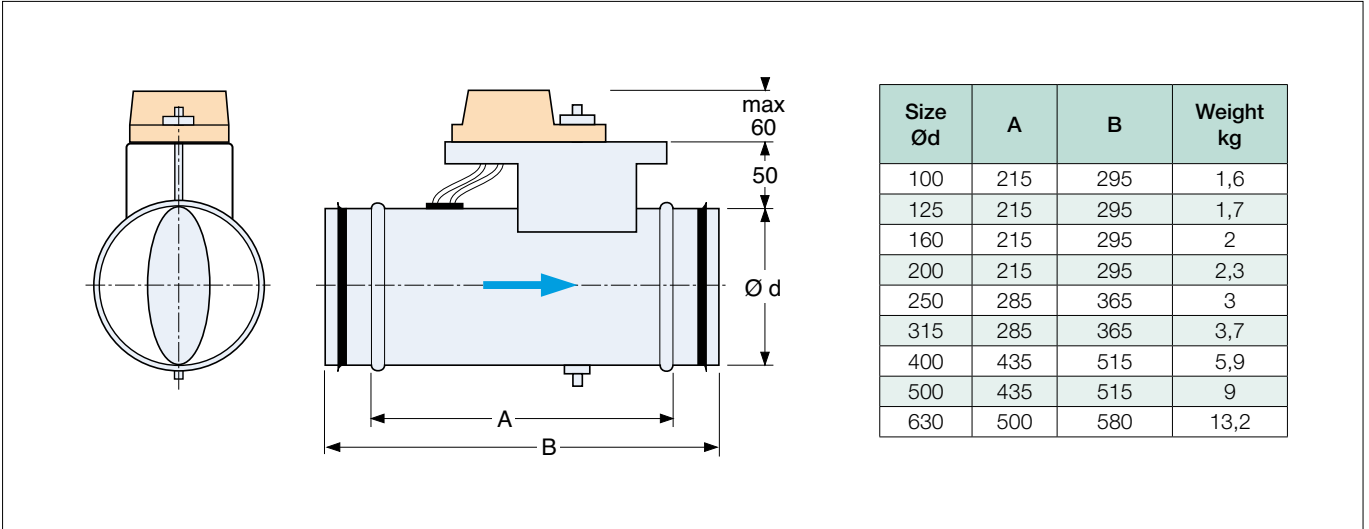

Installation

A sufficiently long straight section and correct installation are crucial for low measurement uncertainty in the duct when measuring the flow. The required straight section after a bend is shown in the figures below.

For other disturbance sources, e.g. T-piece, a straight section of at least 5 x ØD is recommended before the unit.

Duct's nom. diameter = ØD

Method error, $m_2 = 5\%$

NB:

- The measurement tube must be mounted at a 90° angle to the level of the bends.
- The measurement tube must not be placed after two 90° bends on a level perpendicular to each other (so-called configuration in the space).
- For a cleanable design mount the damper with two union pieces.

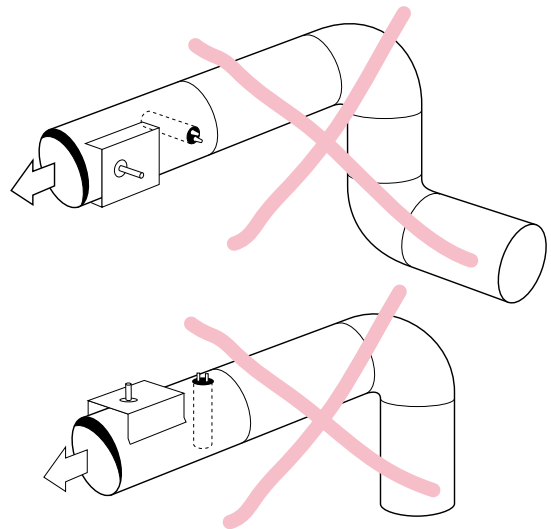
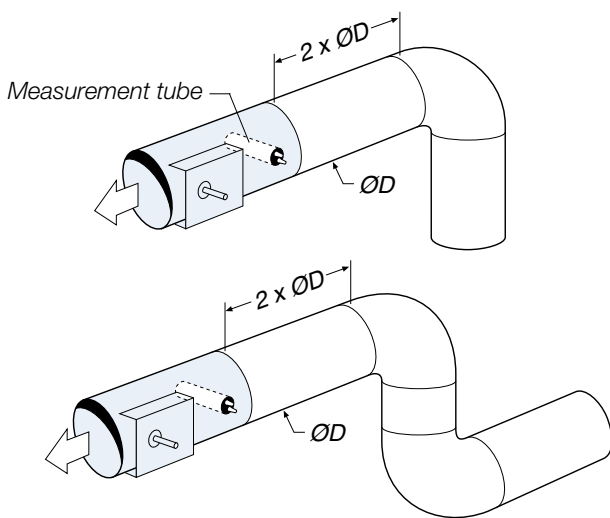



Variable/constant flow device BVAV-2

Flow ranges

The diagrams show the ratio between nominal flow and actual value signal (U_s) for each size.

BVAV-2, size 100-250

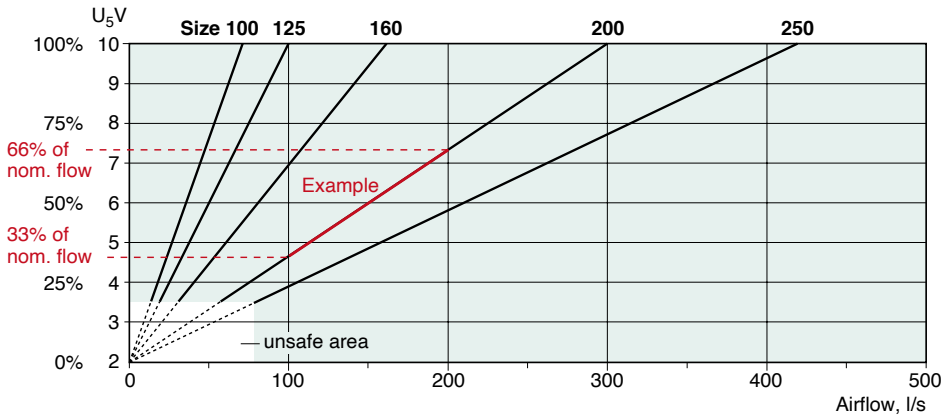

BVAV-2, size 315-630

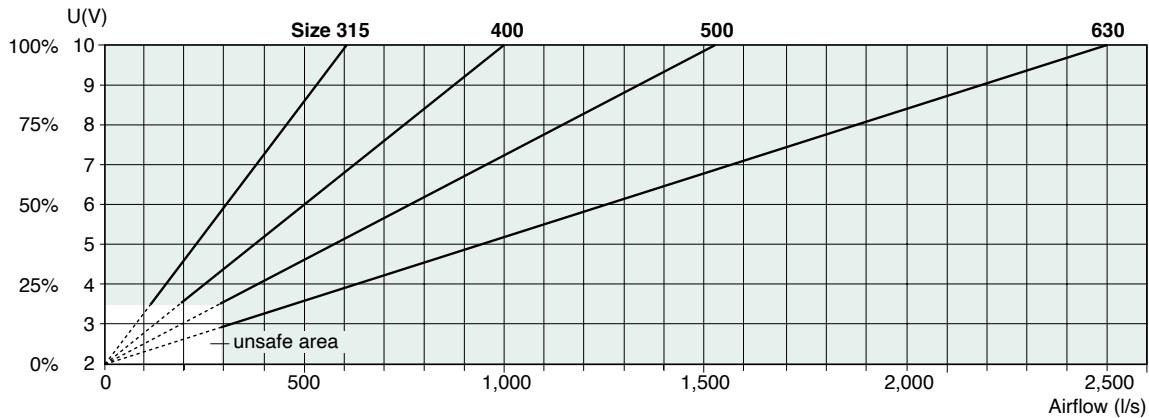

Damper working area

Size	Nom. flow l/s	Max. flow l/s	Min. flow l/s
100	70	21-70	12-70
125	100	30-100	20-100
160	160	50-160	35-160
200	300	90-300	50-300
250	420	130-420	90-420
315	600	180-600	120-600
400	1000	300-1000	200-1000
500	1530	460-1530	300-1530
630	2500	750-2500	400-2500

Max. adjustable flow is between 30-100% of nom. flow.

At min. flow below the recommended min. flow increases measurement uncertainty.

Example:

Conditions:

- Flow, max. 200 l/s, min. 100 l/s

Select size 200.

Nom. flow = 300 l/s

Max. flow = 200 l/s

Min. flow = 100 l/s

(all of the above flows are set from factory)

The actual value output U is not affected by the V_{max} and V_{min} setting.

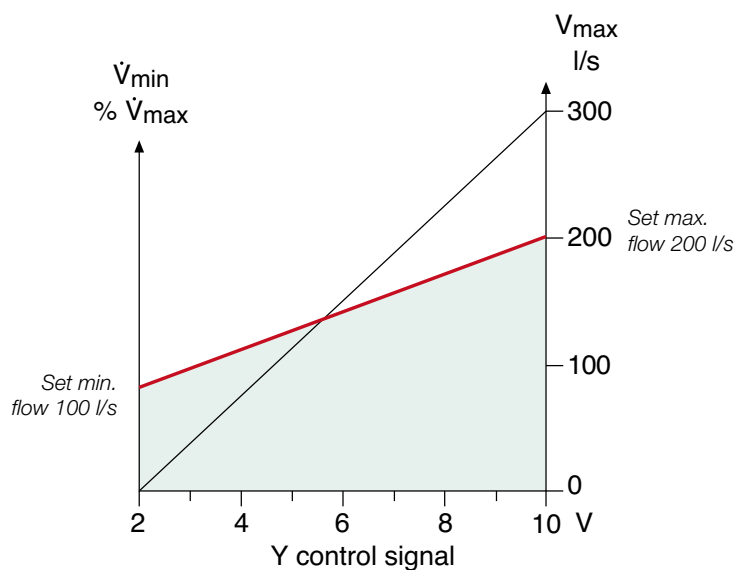



Dimensioning diagram

Size 100

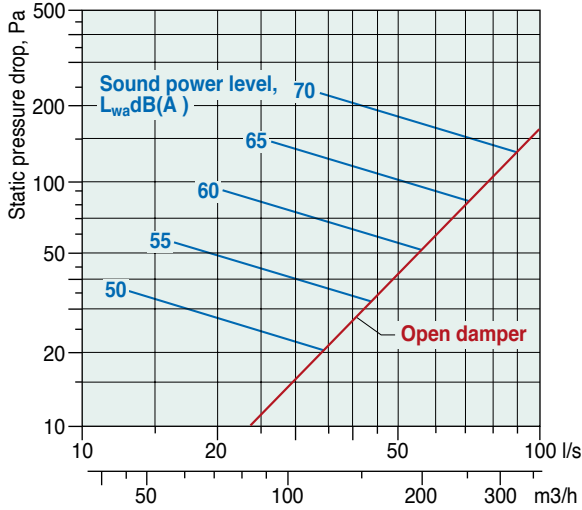

Size 125

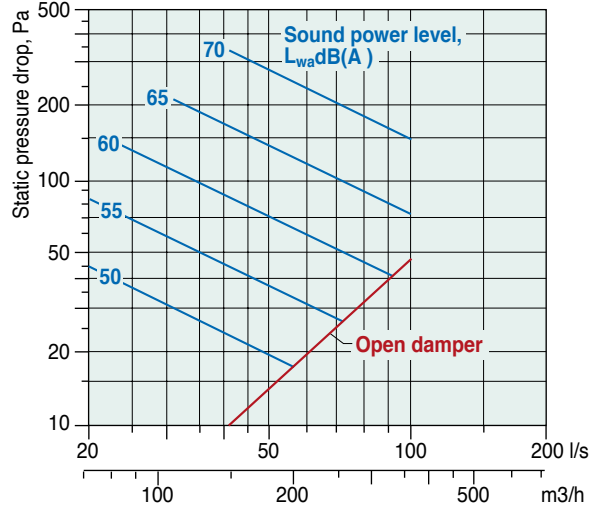

Size 160

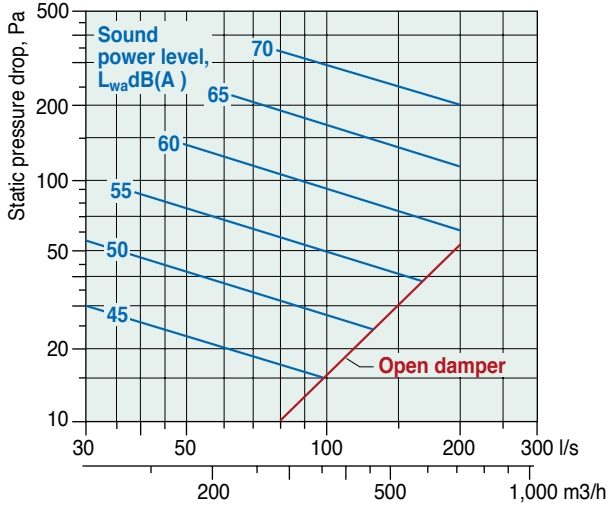

Size 200

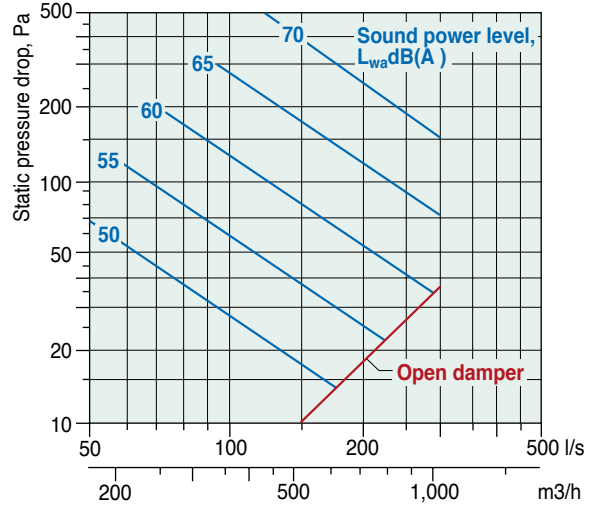

Size 250

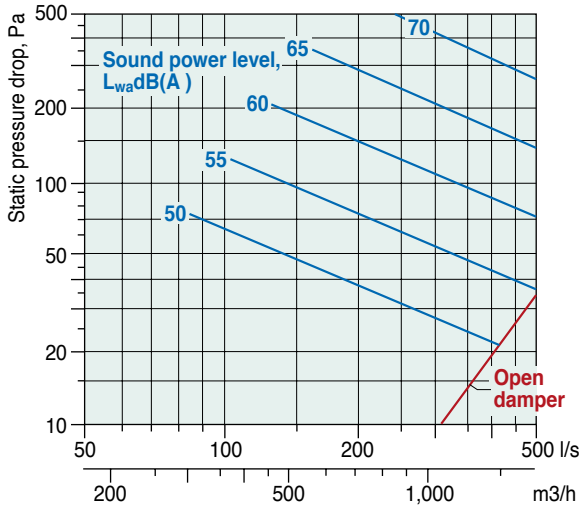

Size 315

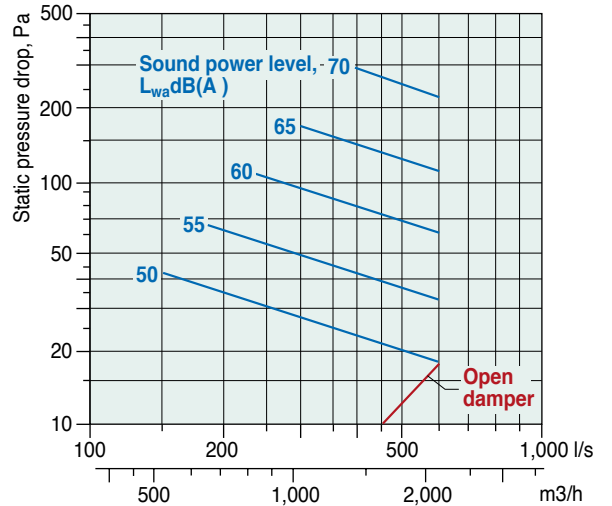



Size 400

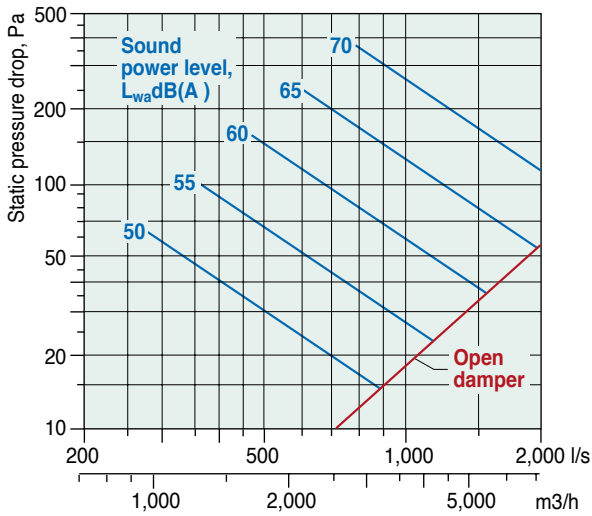

Size 500

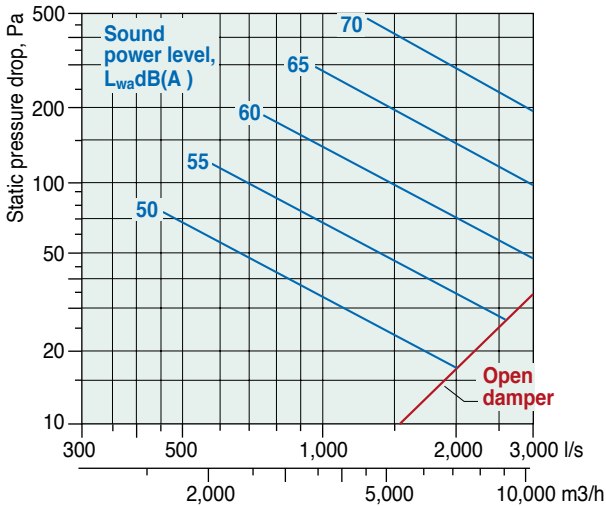

Size 630

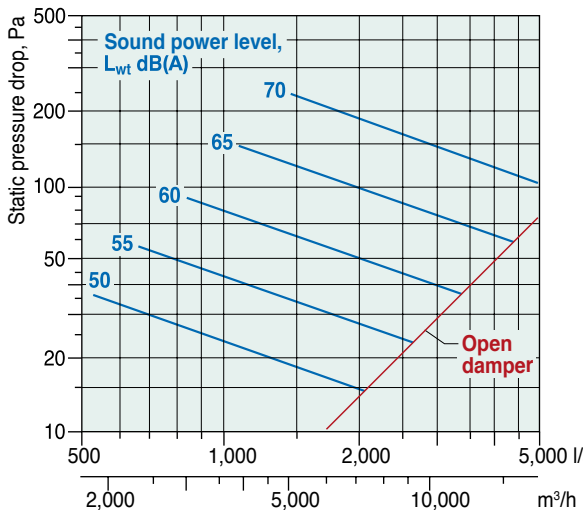

Sound data

Correction of sound power level, L_{Wok} , in octave band

$$L_{Wok} = L_{wa} + K_{ok}$$

Correction, K_{ok}

Size	Mid frequency (octave band) Hz						
	125	250	500	1000	2000	4000	8000
100	11	-1	-4	-12	-13	-22	-29
125	10	-3	-5	-11	-14	-20	-29
160	9	1	-2	-10	-13	-18	-28
200	8	0	-2	-10	-13	-17	-28
250	6	0	-2	-6	-11	-13	-27
315	5	0	-3	-7	-10	-12	-24
400	4	1	-4	-8	-10	-12	-22
500	4	2	-5	-9	-11	-12	-21
630	3	3	-6	-10	-11	-12	-20

Electrical data

BVAV-2

AC 24V, 50/60Hz, DC 24V

AC 19,2...28,8V, DC 21,6...28,8V

Output: 3-3,5 W (5-5,5 VA)

Sound level: 35 dB(A)

Work range pressure sensor 2-300 Pa

Ambient temp.: 0°C - 50°C



Alt. 1. Installation of separate VAV devices

Control signal from e.g. the room regulator or DUC controls the VAV damper. The actual value signal can be forwarded for external monitoring of the current flow.

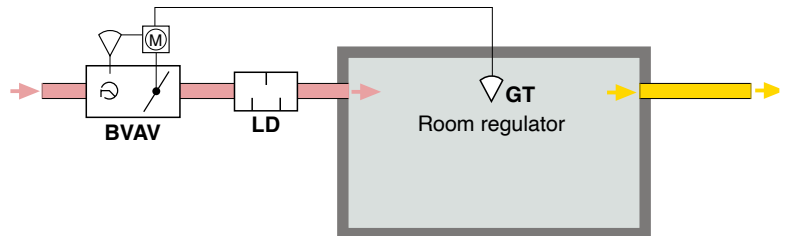

Wiring diagram

BVAV-Compact, NMV-D3-MP

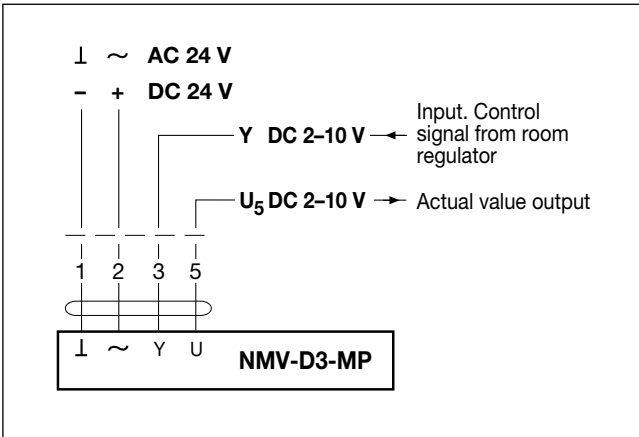

Alt. 2. Supply and exhaust air are controlled in parallel

The control signal from the room regulator or DUC, controls the supply air and exhaust air devices in parallel. The air flow for the devices can be set individually. The output signals from each device can be forwarded for external monitoring of the actual flow.

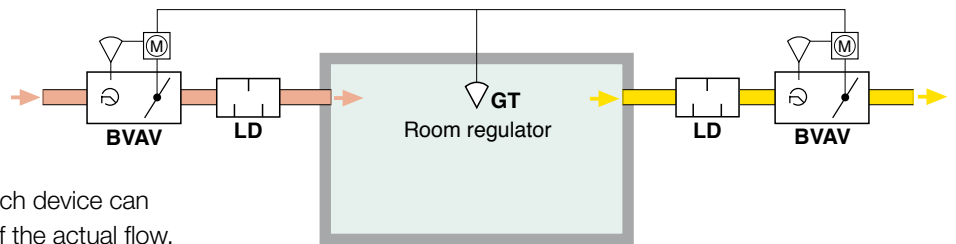

Wiring diagram

BVAV-Compact, NMV-D3-MP

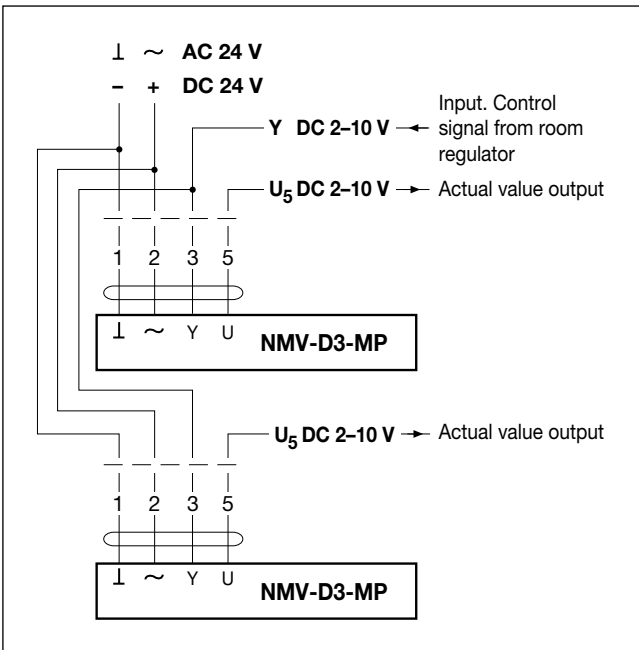



Variable/constant flow device BVAV-2

Alt. 3. The exhaust air is slave controlled by the supply air

The control signal from the room regulator or DUC, controls the supply air device (BVAV master).

The exhaust air device (BVAV slave) is controlled by the supply air device's control signal (U_5 output). Accordingly, the slave follows the master. The flow ratio between slave and master devices depends on the set max. flow of the slave device (normally 100%). The actual value signal from each damper can be forwarded for external monitoring of the current flow. If this connection option is used, the master and the slave need to be the same size.

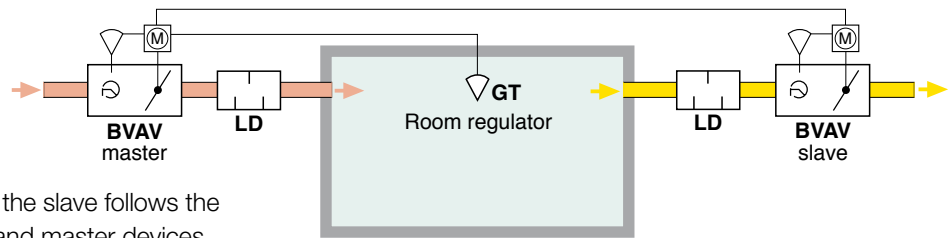

This setting option must be made known before delivery of the VAV devices.

Wiring diagram

BVAV-Compact, NMV-D3-MP

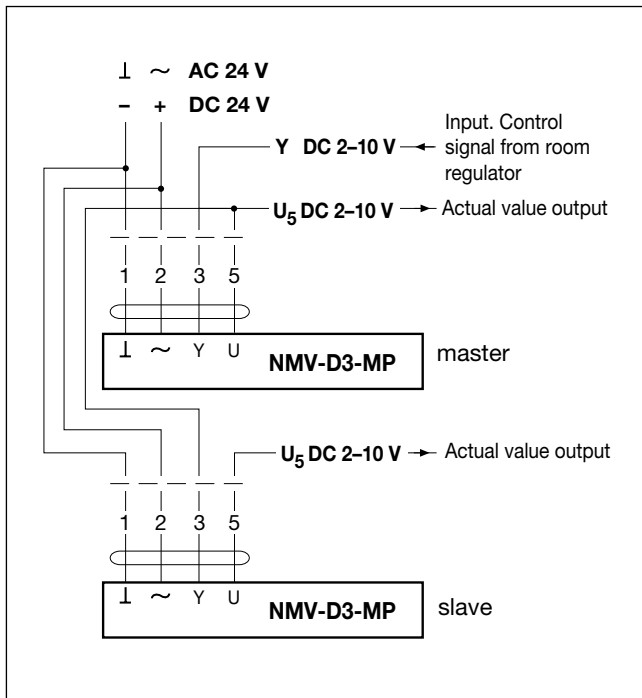



Alt. 4. Constant supply air flow

The VAV device maintains a constant flow preset at the factory. The device is therefore not normally controlled by an external control signal. The output signal can be forwarded for external monitoring of the actual flow. The VAV device can be force-controlled to different operational requirements.

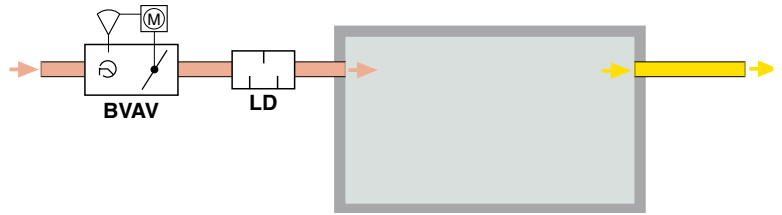

Wiring diagram

BVAV-Compact, NMV-D3-MP

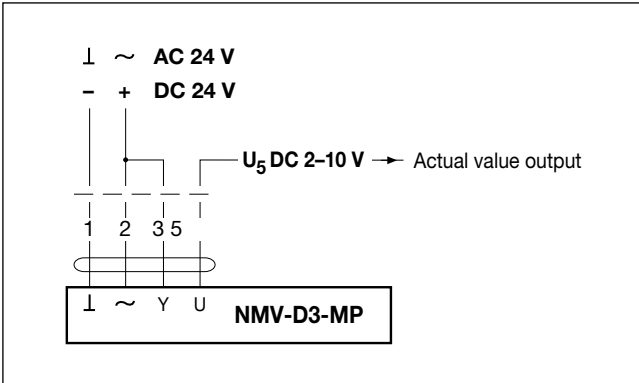

Control functions for BVAV-Compact

With the help of contact functions, the supply air damper (BVAV-Compact) can be regulated to closed, min. flow, variable flow and max. flow and completely open.

Wiring diagram

BVAV-compact, NMV-D3-MP

