

# RABCR

Circular modulating fire damper



FIRE SAFETY



CE

01/09/2021

[www.bevent-rasch.com](http://www.bevent-rasch.com)



**BEVENT RASCH**

AIR SOLUTIONS – FOR A BETTER TOMORROW



## Quick facts

- Fire resistance class E60 / E120S
- Full protection against the spread of combustion gas
- Sizes from 100 mm to 630 mm
- Prefitted regulating safety actuator 24V
- Installation in ducts
- Easy regulation of flow
- Available in MagiCAD
- CE-marked building product according to 15650:2010

## Two dampers in one!

Bevent Rasch has developed a fire damper E60/E120-S with modulating actuator. This means the air flow can be adjusted with the damper blade angle 0-100% via input signal 2-10 V. It can also be used as adjustment damper or control damper and have a complete fire function at the same time.

## Use

Damper in combination with walls or joist systems for fire separation of heating, ventilation and air conditioning installations in buildings. In accordance with the harmonised European standard EN 15650:2010. In designs according to associated documents, installation instructions and when the damper is used in combination with smoke detectors and monitoring system, the spread of combustion gases is prevented. No further action against the spread of combustion gases is required.

## Performance

EC certificate according to EN 15650:2010

**0402-CPR-SC0058-13**

Classification of fire resistance according to EN 13501-3

**E120 (ve i <-> o) S**

**E120 (ve ho i <-> o)**

**E60 (ve ho i <-> o)**



## Installation

RABC is installed in horizontal or vertical ducts that pass through fire cell separating building elements, according to the adjoining installation instructions. When installed as termination device, fit non-combustible grilles designed for the damper on the unconnected sides.

## Actuator

RABCR is always supplied with an electric safety actuator with spring return complete with thermal sensor with push-button for local manual operating test. The sensor disconnects the power to the actuator if the temperature exceeds 72°C inside or outside the damper.

For dampers ≤ Ø400 actuator BRL24 is used with micro switch for indication of closed damper. Larger sizes are equipped with actuator BRS24 with micro switch for indication of open and closed damper. Control signal 2-10V. 24V actuators are always used in connection with the MRB monitoring system. Note that the RABCR damper is always supplied with an actuator. Mounted MRB box is available as accessory.



## Control and monitoring

When the damper is used to prevent the spread of fire and combustion gases it must be closed via impulses from the smoke detector. This must be fitted in the ventilation duct in the proximity of the damper or in another suitable location. Smoke detectors are monitored by means of Rasch's MRB system or the like. The MRB monitoring system also performs automatic operating checks on the damper every 48 hours and is designed so that faults are indicated immediately. For this function check, the control unit RCRS is used. Other MRB control units can not be used for this type of damper. To the RCRS one damper and one smoke detector can be connected. Also included is input signal 2-10V, external override to closed and open position from for example a BMS system and external function test. Outputs for alarm and actual value signal. Adjusting of max/min position of the blade is easily set from the RCRS. For detailed information of RCRS, see Monitoring system MRB.

## Size

Ø100 – 630 mm.

## Design

Modulating smoke dampers are delivered prepared for external insulation. The control signal can come from a room controller, air quality sensors, or other devices that provide 2-10V DC output. The actuator provides a feedback signal to 2-10V DC depending on throttle position. When power is lost the damper closes with actuator spring.

## Material and surface finish

Casing and components of galvanized steel sheet according to environmental class C3. Fabric seals. EPDM spiral duct connections.

## Miscellaneous

All data refers to standard versions of dampers. When setting the max-min flows, it is appropriate to using measuring units like BRRM/BRMR.

## Specification

Example:

**Regulating fire damper**                      **RABCR - 250 - 1 - 0**

*Size*

Nom. diameter Ød, mm

*Material*

Galvanized sheet steel	= 1
Stainless AISI 3041 – EN 1.4301	= 2
Stainless AISI 316L – EN 1.4404	= 3

*MRB control unit*

Without MRB control unit	= 0
Fitted with MRB control unit (RCRS)	= 1
Fitted with MRB3 control unit (RCTU)	= 5

*Note. Factory fitted actuator always included.*

## Accessories

<b>RCRS</b>	MRB system for 1 damper
<b>RCKD/-RD</b>	Smoke detectors
<b>TR24-M</b>	Temperature controller
<b>aSENSE</b>	Air quality sensor
<b>RCTU</b>	Damper module for MRB3 system
<b>FENIX2</b>	max 2 dampers
<b>FENIX4 / FENIX+</b>	max 16 dampers



**Dimensions and weight**

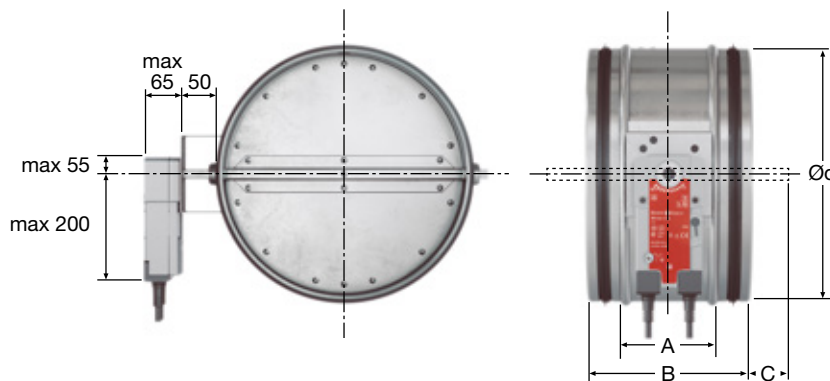

Size Ø mm	Spiro		C	Weight, kg <sup>*)</sup>
	A	B		
100	120	200	-	2,8
125	120	200	-	3
160	120	200	-	3,2
200	120	200	-	3,5
250	120	200	30	4
315	120	200	60	4,9
400	210	290	60	8,4
500	210	290	110	10,3
630	210	290	180	13,4

\*) When fitted with RCTU, add 150g and when fitted with RCRS, add 500g.

**Electrical data**

Actuator type BRS... BFL...

Sizing, max ..... 10 VA 6,5 VA

Running time;

- motor opening ..... 150 s 60 s

- spring return, max ..... approx 20 s 20 s at -10 to +55°C  
60 s at -30 to -10°C

Protection class ..... IP 54

Power supply ..... 24V~ ±20%, 50/60 Hz

- Control signal Y ..... DC 0-10V @input resistance  
100 kΩ(0,1 mA)

- Operating range ..... DC 2-10V (control signal Y)

- Measuring signal U ..... DC 2-10V @max. 0,5 mA  
(for 0-100% opening angle)

Ambient temperature ..... -30° to +50°C

Safety temperature..... -30° to +75°C  
(24 hrs. guaranteed safety)

End position contacts:

- load ≤ 300 mW ..... min 1 mA/5V~,  
max 100 mA/250V~

Applicable after exceeding the above values:

- load > 300 mW ..... min 100 mA, max 3 A/250~

Sound level when opening approx 45 dB(A)

Sound level when closing approx 62 dB(A)

**Actuator - damper sizes**

Actuator BFL24-SR-T is supplied to damper sizes Ø100-315 mm.

Actuator BRS24-T is supplied to damper sizes Ø400-630 mm.



Wiring diagram

Option 1 – Connection to monitoring system

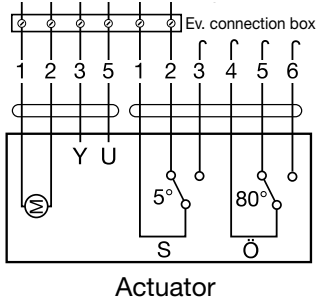

Option 2 – Connection to RCTU

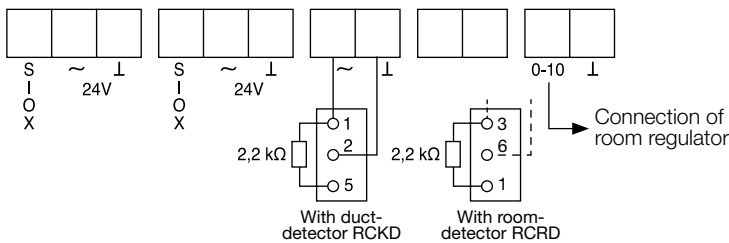

BF24-SR, BRS24, BFL24-SR

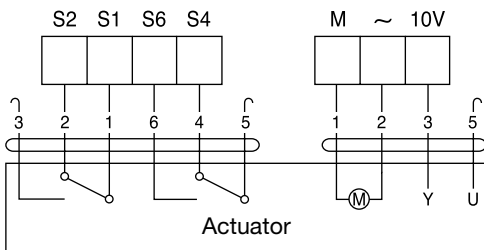

Option 3 – Connection to RCRS

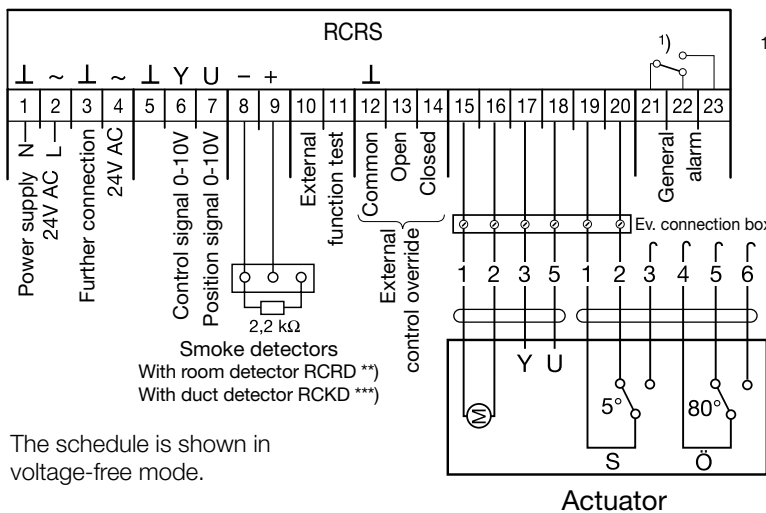

The schedule is shown in voltage-free mode.

Note.

- For 2-mode operation: the damper goes to minimum position when the control signal is 0V or broken and maximum position at 10V input signal or 24V at terminal 6.
- Power supply and control signal is connected to a common system neutral.

1) Potential-free contact max. 24V AC, 3A. Drawn in voltage-free/alarm mode.

\*) Limit switch for Open position is only included on BRS24-actuators

\*\*) With room detector RCRD connected in series

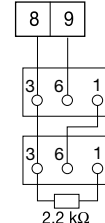

\*\*\*) With duct detector RCKD connected in series

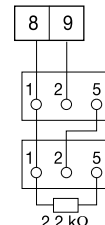



Size chart

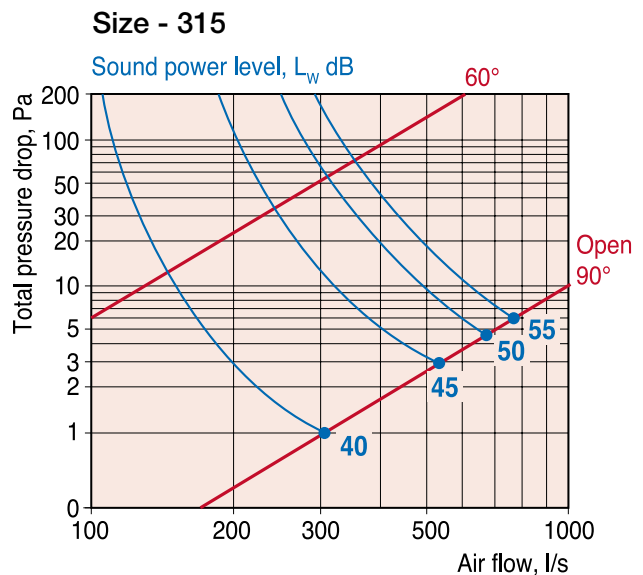
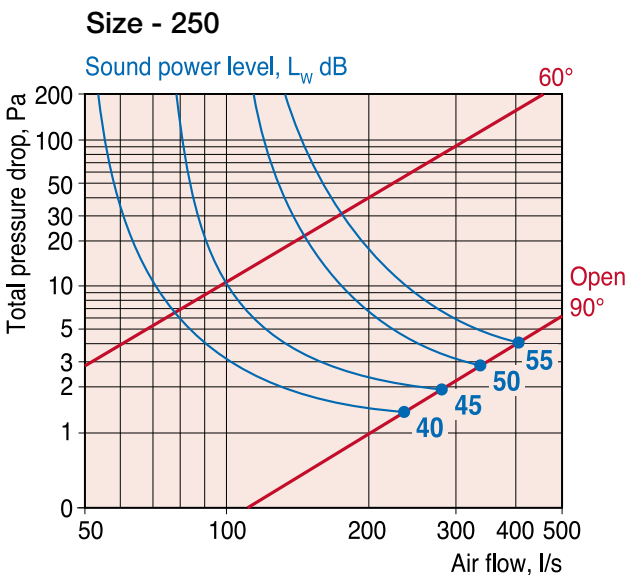
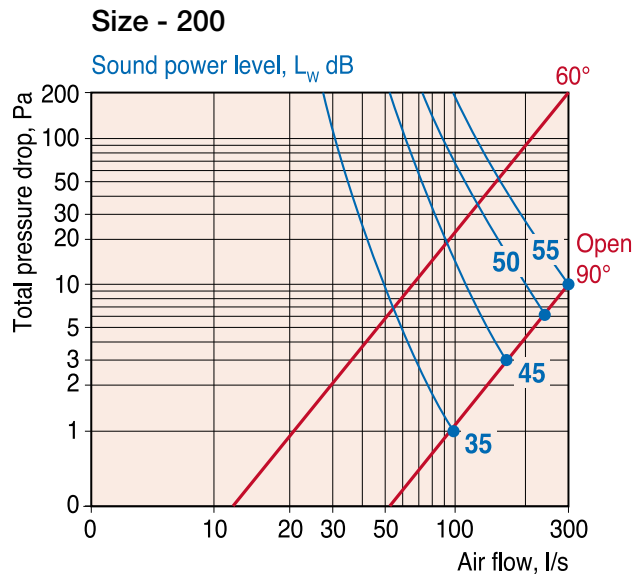
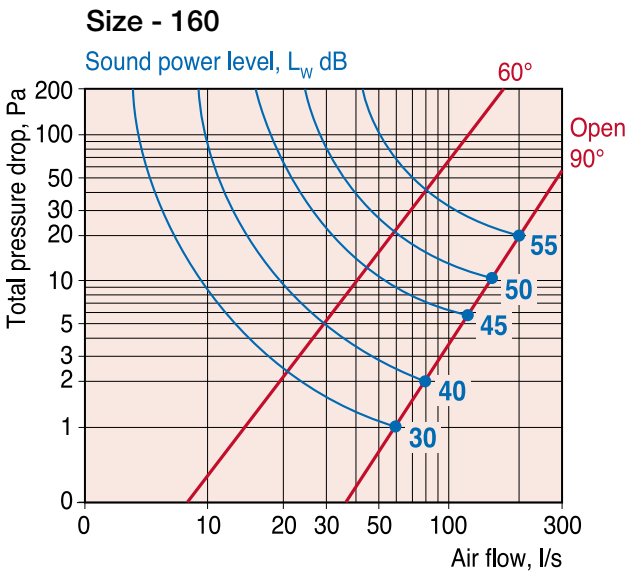
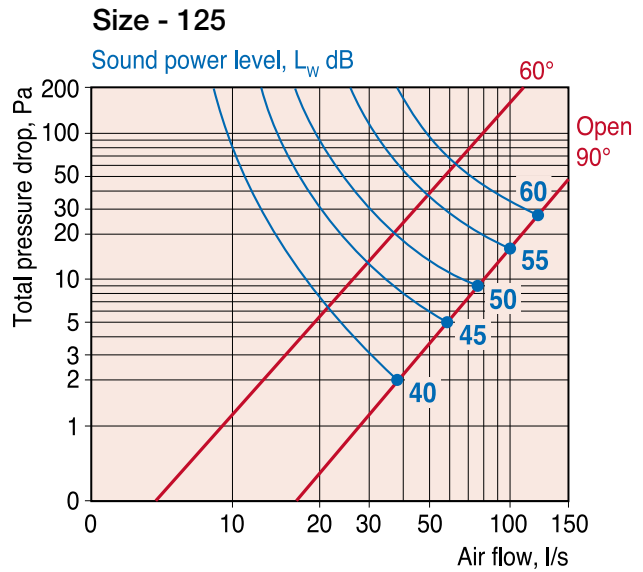
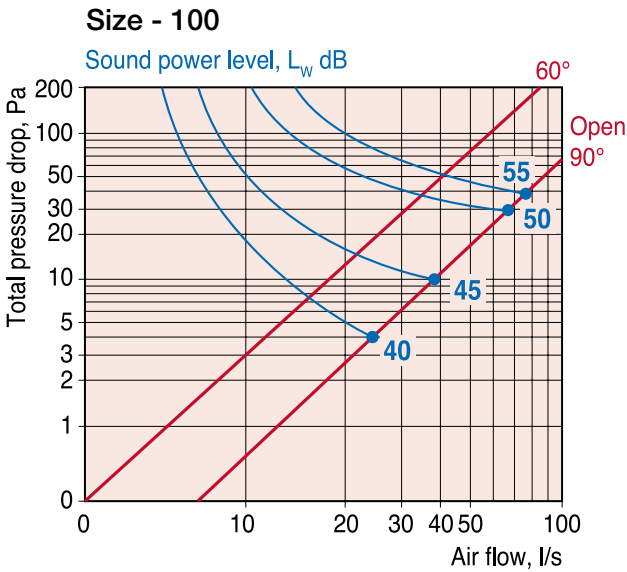



**Sound data**

Correction of sound power level,  $L_{W_{ok}}$ , in octave band

$$L_{W_{ok}} = L_w + K_{ok}$$

Correction,  $K_{ok}$

Size Ø mm	Centre frequency Hz							
	63	125	250	500	1000	2000	4000	8000
100	-3	-7	-12	-19	-29	-27	-33	-32
125	-4	-5	-8	-13	-21	-25	-31	-35
160	-3	-4	-7	-13	-18	-22	-29	-37
200	-2	-8	-14	-20	-24	-28	-35	-41
250	-2	-9	-14	-19	-19	-28	-35	-42
315	-3	-8	-12	-12	-18	-24	-31	-35
400	-5	-7	-11	-6	-15	-22	-27	-28
500	-2	-10	-15	-13	-18	-24	-22	-31
630	0	-17	-3	-5	-10	-15	-22	-30
Tol. ± dB	2	4	5	7	10	10	9	7

**Size - 400**

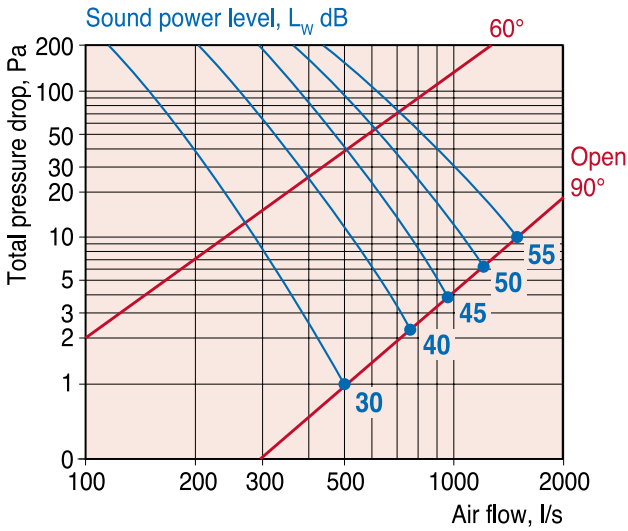

**Size - 500**

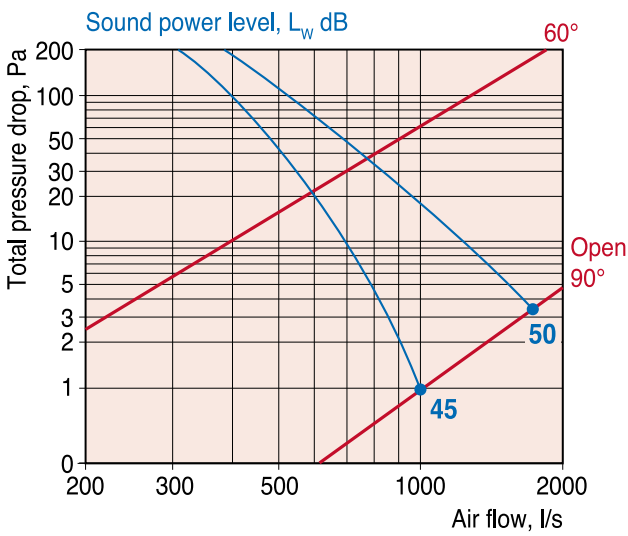

**Size - 630**

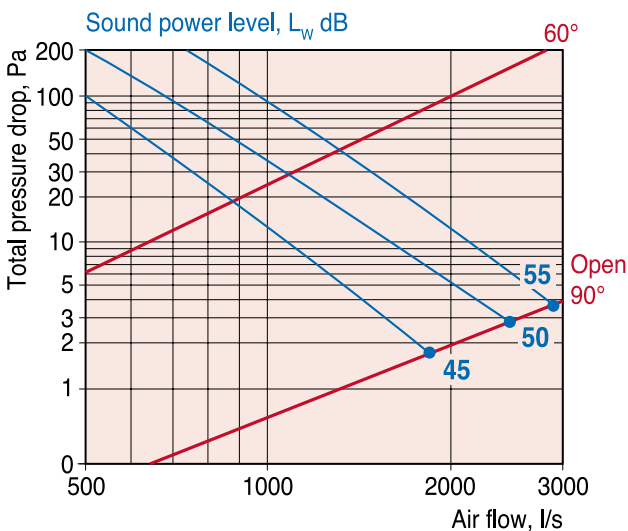



## Installation instruction

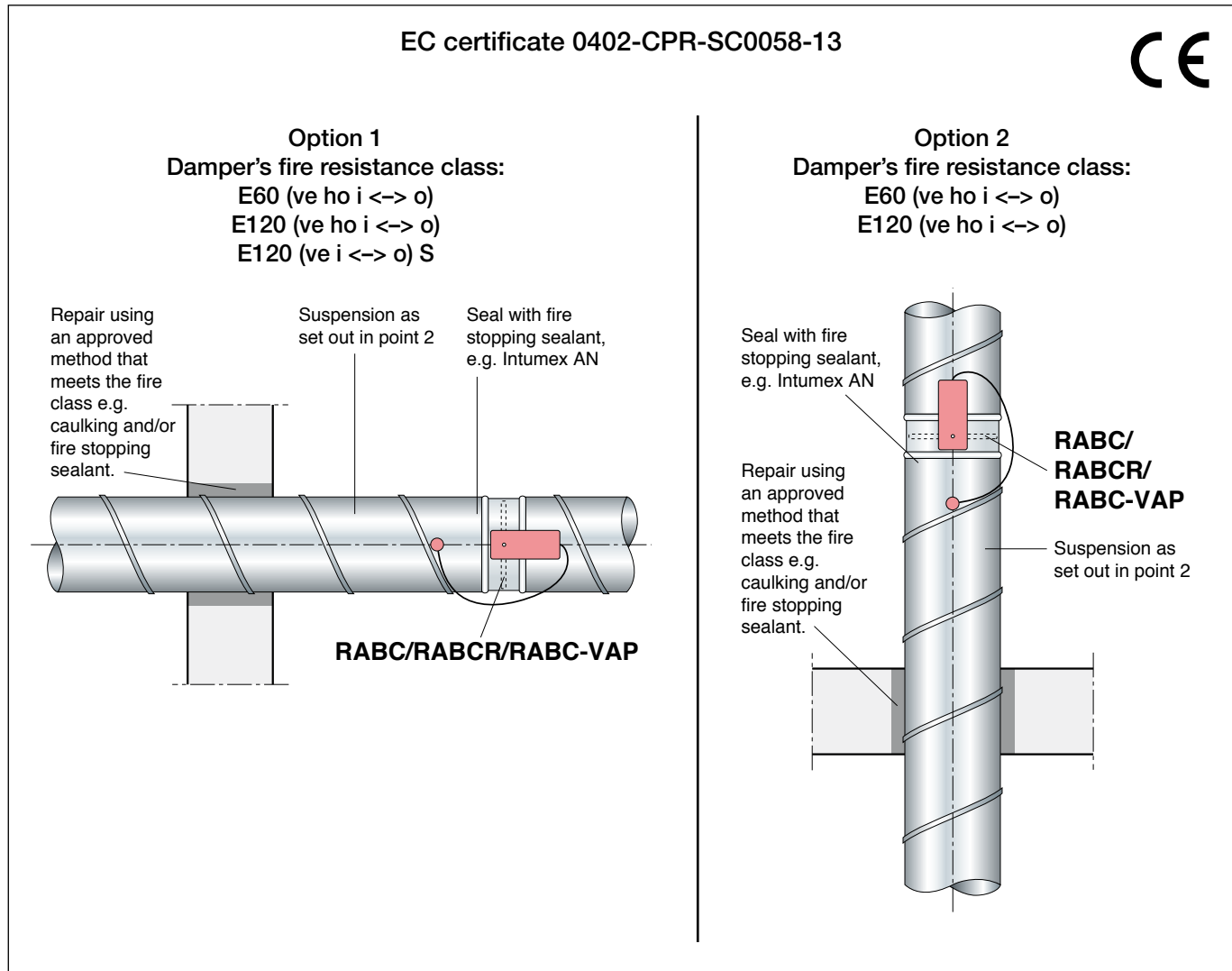

### Options 1 and 2

1. Secure the damper in the duct and seal with fire stopping sealant, e.g. Intumex AN.
  2. Install the duct system according to applicable requirements. Between the damper and the penetrated building element the maximum spacing between hangers is 1500 mm. Use M10 drop rods and cradles or equivalent.
  3. Install the thermal sensor with the sensor body in the air stream without obstructing the movement of the damper blade.
- *Minimum distance between dampers must be 100 mm.*
  - *Minimum distance to joist structure/wall must be 75 mm.*
  - *No openings between dampers and fire separating building elements.*
  - *Optional installation of the damper spindle.*
  - *The damper can be installed in diagonal duct systems.*